



Northeastern University
Library







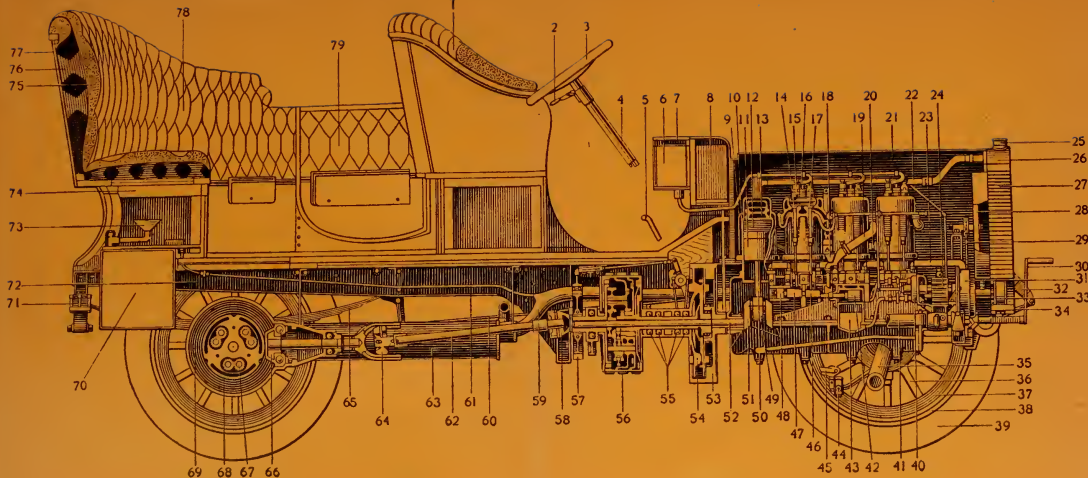

CROSS-SECTIONAL DIAGRAM OF A FOUR-CYLINDER TOURING CAR.

- 1—Divided front seat for chauffeur.
- 2—Throttle lever.
- 3—Steering wheel.
- 4—Steering pillar.
- 5—Brake or clutch lever.
- 6—Spark coil.
- 7—Spark coil vibrator.
- 8—Gravity feed gasolene tank.
- 9—Water jacket wall.
- 10—Cylinder wall.
- 11—Piston.
- 12—Piston ring.
- 13—Compression chamber.
- 14—Inlet valve.
- 15—Spark plug.
- 16—Relief cock.
- 17—Exhaust valve.
- 18—Mixer.
- 19—Intake pipe.
- 20—Exhaust pipe.

- 21—Engine Bonnet.
- 22—Water circulating pipe.
- 23—Water circulating pipe.
- 24—Oil pump gear.
- 25—Radiator cap.
- 26—Water tank.
- 27—Radiator.
- 28—Air Cooling fan.
- 29—Driving chain for fan.
- 30—Starting crank.
- 31—Water pump.
- 32—Forward spring support.
- 33—Commutator.
- 34—Forward spring.
- 35—Tubular front axle.
- 36—Spoke.
- 37—Felloe.
- 38—Rim.
- 39—Pneumatic tire.
- 40—Oil governor, actuating pump.

- 41—Tubular sub-frame of engine.
- 42—Oil governor piston.
- 43—Reserve oil chamber.
- 44—Parallel rod end.
- 45—Steering rod.
- 46—Cam actuating the exhaust valve.
- 47—Cam actuating the inlet valve.
- 48—Sliding bearing for cam shaft.
- 49—Connecting rod end.
- 50—Connecting rod.
- 51—Crank.
- 52—Crank shaft of engine.
- 53—Fly-wheel.
- 54—Expansion clutch.
- 55—Ball bearing for transmission shaft.
- 56—Planetary transmission.
- 57—Transmission brake drum.
- 58—Universal joint.
- 59—Exhaust pipe.
- 60—Brake rod.

- 61—Pressure feed pipe for gasolene.
- 62—Driving shaft.
- 63—Muffler.
- 64—Universal joint.
- 65—Rear side spring.
- 66—Bevel gear driving pinion.
- 67—Differential pinion stud.
- 68—Differential pinion.
- 69—Differential housing.
- 70—Main gasolene tank.
- 71—Rear spring support.
- 72—Pressed steel side frame.
- 73—Swinging filler for gasolene tank.
- 74—Wooden frame of body.
- 75—Upholstering.
- 76—Upholstering spring.
- 77—Aluminum body.
- 78—Tonneau.
- 79—Side entrance door.



LOOK WITHIN



TRADE MARK

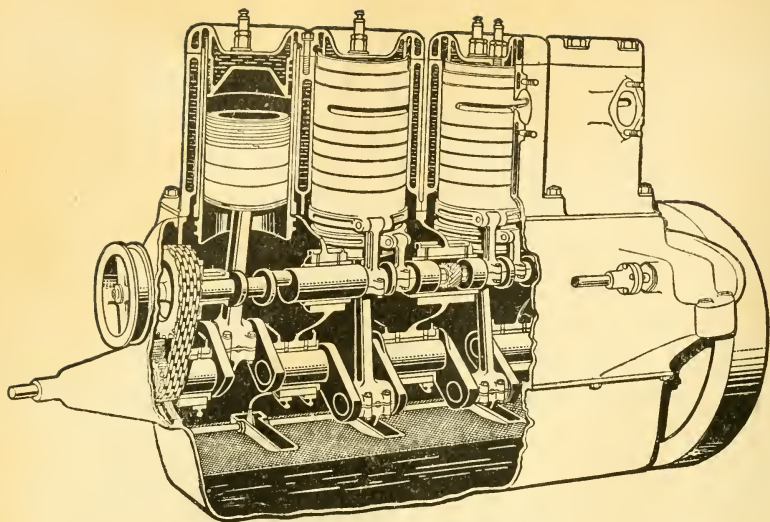

THE KNIGHT SLIDING SLEEVE VALVE ENGINE.

This engine, as shown above, is of the four cycle type with $4\frac{1}{2}$ by $5\frac{1}{2}$ cylinders, cast in pairs. The A. L. A. M. rating is 38 horse power, or as claimed by the builders, 70 to 85 horse power.

The Knight engine has in place of poppet valves *two sliding telescopic sleeves*; these contain the ports and perform the valve duties, being driven by short connecting rods from a half speed shaft at the side.

In operation, the right hand ports of the sleeves register with each other on the suction stroke, exposing a large opening through which the charge of fuel mixture enters; at the beginning of the compression stroke, the sleeves slide, one up and one down, thus closing the ports for compression.

All ports remain closed until the end of the power stroke, when the left hand ports open and register with each other, leaving a large exit for the exhaust of the burnt gases.

The advantages claimed for this valve gear are large port openings, and noiseless operation; the above cut illustrates the Columbia design of the Knight engine.

Book, Charles Edwin

THE THOUGHT IS IN THE QUESTION; THE INFORMATION IS IN THE ANSWER.

Audel's

ANSWERS

ON

AUTOMOBILES

FOR

Owners—Operators—Repairmen

RELATING TO

The parts, operation, care, management, road driving, carburetters, wiring, timing, ignition, motor troubles, lubrication, tires, etc., including chapters on the storage battery, electric vehicles, motor cycles, overhauling the car, etc.
Fully illustrated and indexed.

BY

GIDEON HARRIS *and Associates*



THEO. AUDEL & CO., PUBLISHERS

7 Imperial Arcade, London

63 Fifth Ave., New York

1912

TL
151
B7
1912X

Copyright, 1911

by

THEO. AUDEL & CO., NEW YORK

Entered

Stationers Hall, London

Printed in U. S.

9358001433785

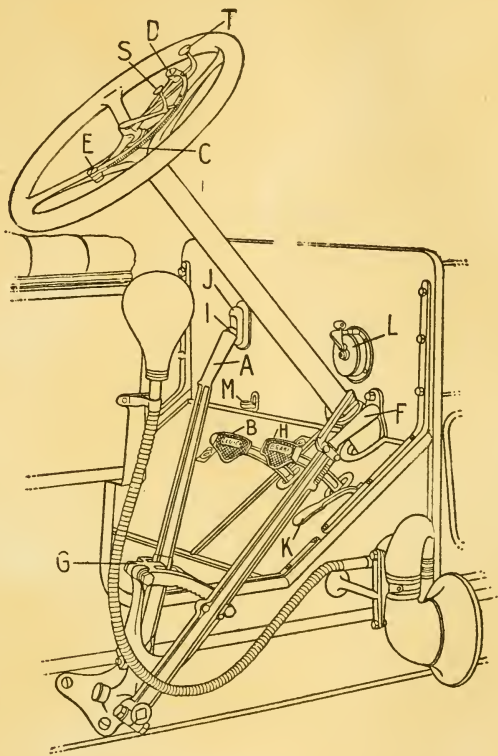

CONTROL

- | | |
|----------------------------------|----------------------------------|
| A—Gear changing hand lever; | H—Rear wheel brake foot lever; |
| B—Friction clutch foot lever; | I—Gear changing hand lever |
| C—Ignition and throttle control | lock rod head; |
| operating lever sector; | J—Oiler dash sight feed; |
| D—Ignition and throttle control | K—Accelerator foot lever; |
| operating lever sector bolt; | L—Coil; |
| E—Ignition and throttle control | M—Cylinder compression relief |
| operating lever sector bolt; | operating rod handle; |
| F—Rear wheel brake hand lever; | S—Spark control operating lever; |
| G—Gear changing hand lever gate; | T—Throttle control operating |
| | lever |

143378

FOREWORD

The Thought is in the Question; the Information is in the Answer.

Now, the Teacher possesses information which he is more than willing to communicate to the pupil; the former's fund of knowledge we may suppose is derived from persons, books, and observation; he knows the exact rules that govern the Mechanic Arts; these relate always to things to be done; he also, it may be assumed, is familiar with the broad collection of Industrial Facts which, when arranged and rightly ordered, have become known as an important part of Science.

Against and over this array of accomplishments of the Teacher, stands the expectant Scholar with his mind a blank or dimly illumined.

The problem is, in its first stage one of transference, in which the Scholar asks a question relating to the problem to be made clear, and the Teacher replies with an informing Answer.

The communication has been made by a question and an **Answer**. These being followed by a repeated exercise of similar import, have completed the mental achievement, and there are two persons instead of one who possess—let it be said—the desired secret of the Art. Hence :

There must, in similar cases, perforce be: 1, an Informing (and willing) mind, and 2, a Receptive mind, which is able and anxious to acquire. The first is often, it may properly be said, made willing by a Fee, and the second also animated by the hope of future reward, as of Wages.

The ideas now advanced, it may be explained, are confined mainly to the Mechanic Arts, whose secrets are handed down from generation to generation.

PREFACE

There are no hard and fast rules which can be laid down to insure a person becoming proficient in driving an automobile. Some people have the erroneous idea that only those who have received a first class mechanical training can become good operators.

A man who is a first class horseman will usually make a first class driver of an automobile, or, in other words, the man who shows mercy to his beast will show mercy to his car. This type of driver does not belong to that class generally found at the side of the road with something broken or out of order. An automobile, if properly designed, will withstand a great deal of rough usage, but there is bound to come a time, sooner or later, when it will rebel at being used like a battering ram.

The automobile is a machine, which involves the consideration of an extensive range of facts in several widely separated departments of mechanical knowledge, hence the study of its construction and operation is a liberal education in itself. Like any other piece of machinery, it requires attention, care, and intelligent handling. If the highest degree of efficiency be desired, the operator should spend a little time each day going over the machine to see that it is well lubricated, and the necessary adjustments properly made, also that the whole car is in working order.

PREFACE

The object of this book is to give, in a form so simple and concise that anyone can easily understand it, the information necessary for the proper operation, care, and maintainance of an automobile.

In order to successfully run a gas engine, it is of prime importance that the operator understand the principles of carburetters and ignition. With this in view the author has given considerable space to these subjects, which should receive careful attention before reading the instructions on engine operation

In order to adapt the book to the use of students, the subject matter is presented in the form of questions and answers; where technical terms are used they are either explained or made clear by the wording of the answer. In order not to divert the mind and confuse the reader, the answer is always made short and direct, giving simply the information demanded by the question.

Detailed explanations, or items of secondary importance, are printed in small type in separate paragraphs, hence, on first reading, the student may, if he desire, omit these paragraphs in order to more quickly grasp the VITALS of the subject, and afterwards enlarge the knowledge thus acquired by a complete reading of the book.

To aid the reader in quickly finding any desired information, the book has been thoroughly indexed, each item being entered under every possible heading.

TABLE OF CONTENTS

INTRODUCTORY.....	1—16
Foreword—preface—table of contents—index	}
—caution.....	
THE AUTOMOBILE.....	17—20
Development—principal parts—power plant— running gear—control.	
THE GAS ENGINE.....	21—26
Working principle—parts—valve gear—auxil- iaries.	
THE CYCLE OF A GAS ENGINE.....	27—36
Definition—four cycle—multi-cylinders—two cycle—comparison of two and four cycle en- gines.	
OUTLINE OF GAS ENGINE PRINCIPLES....	37—42
Source of energy—efficiency—units—behaviour of the charge—conditions within the cylinder— cooling—losses.	
COOLING SYSTEMS.....	43—53
Necessity for cooling—water jacket—radiator —circulation of cooling water—types of circu- lation pump—pump drive—cooling surface— air cooling system—comparison of water and air cooling systems—the fan—fan drive.	

TABLE OF CONTENTS

FUELS.....	54—68
Origin—distillation—separation of the products of petroleum—practical method of distillation—petrol—hydrometers—handling of gasoline—“stale” gasoline—storage—kerosene—difficulties of use—advantages—alcohol—fuel consumption—conclusions regarding the use of alcohol.	
CARBURETTERS.....	69—124
Definition—distinctions between “carburetter” and “vaporizer”—types—simple explanation of principles—the primary air—the secondary air—float chamber—float feed—offset and concentric floats—float pin or “tickler”—spray nozzle—the mixing chamber—theory of carburetter action—heating—the mixture— <i>surface</i> or “ <i>puddle</i> ” carburetters—“ <i>venturi</i> ” carburetters— <i>how to select a carburetter</i> —ideal requirements—throttle design—calculation of size of carburetter— <i>carburetter adjustments</i> —hand control—carburetter troubles.	
IGNITION.....	125—208
Its importance—early devices—the electrical method universally used—electrical principles: electricity and magnetism—methods of generating electricity—primary and secondary batteries—battery connections—the storage battery—capacity—charging—electrolyte—sulphation—verdigris—mechanical generators—difference between a dynamo and magneto—drive for dynamo—classes of magneto—low tension magneto—high tension magneto, diagram and full explanation of principles—	

TABLE OF CONTENTS

IGNITION—(Continued.)

characteristic features of the *make and break*, and *high tension systems*—the low tension circuit—magnetic spark plug—inductor magneto—“*jump spark*” or high tension ignition—timing devices—induction coils—spark plugs—ignition with plain and vibrator coils—synchronous ignition—ignition with high tension magnetos—special igniting devices—dual and double ignition—*ignition troubles*.

“TIMING” AND BALANCING 209—224

Balancing of single and multi-cylinder engines—timing principles—method of timing make and break system—finding the dead center—timing a magneto—lost motion—single and double cam shafts—wear of gear teeth.

GAS ENGINE OPERATION 225—262

Management—supplies—preparation before starting the engine—lubricants and lubrication—engine adjustments before starting—*cranking*—defective engine operation—back firing—after firing—running down—seizing—low compression—leaks—valve adjustments—carbonized cylinder—smoky exhaust—mixture indications—missing—pre-ignition—the mixture—stale gasoline—ignition disorders and adjustments—weak battery—glazing—loose connections—vibrator adjustment—moisture in coil—defective spark plug—fouling—cold weather—freezing—anti-freezing solutions.

CLUTCHES 263—274

Clutch requirements—construction—*cone clutch*—angularity of friction surfaces—*cone clutch*

TABLE OF CONTENTS

CLUTCHES—(Continued.)

troubles—drum and band clutch—expanding ring clutch—*multiple-disc clutch*—clutch operation—gripping—spinning—slipping—cork inserts.

TRANSMISSIONS.....275—290

Why a “transmission” is necessary—explanation of mechanical principles involved—progressive transmission—selective transmissions—control levers—planetary transmission—frictional contact transmissions.

THE DRIVE.....291—300

Types of drive—universal joints—shaft drive—the “straight line” shaft drive—tortion rods—radius rods—chain drive—objections to chain drive—types of chain—operation of the chain—how to clean a chain—chain drive adjustment—spur gear drive.

THE DIFFERENTIAL.....301—304

Principle of the differential—types: bevel and spur differential.

THE RUNNING GEAR.....305—316

Definition—frame—springs—qualities necessary in a good spring—shock absorber—wheels—large and small wheels—“dishing”

TIRES.....317—334

Advantages—rubber: method of preparation for tires—tire fabric—pneumatic tires: single and double tube—construction—attachment and removal—clincher tires—*tire troubles*—creeping—puncture—rim cutting—cracking—wear—chemical action—rim defects—inflation

TIRES—(Continued.)
 —table of proper loads—dampness—commercial tires—effect of high speed.

BRAKES335—340
 The “service” or “running,” and emergency brake—control—construction—two forms of band brake—equalizer—overheating—braking on long grades.

BALL AND ROLLER BEARINGS341—346
 Principle of the ball bearing—difference between ball and roller bearings—the raceway—“radial” bearing—“full” and “silent” bearings—roller bearing—proper lubricant.

LUBRICANTS AND LUBRICATION347—362
 Importance of using the proper lubricant—duty of a lubricant—theory—wear—cutting—requirements of a lubricant—“body”—graphite: how applied—soapstone—grease—liquid lubricants—oil tests—cold point—flash point—burning point—clearness—suspended matter—purity—test for animal matter—acid test—rancid test—lubrication systems—choice of a lubricant—lubrication schedule.

MOTOR CYCLES.....363—376
 Requirements—the engine—framework—wheels—two cylinder engine—valves and valve gear—ignition—jar absorbing devices—control—timing the valves—the drive—directions for operating.

ELECTRICS.....377—380
 Types—motors—drive—method of attaching the motor—light electric vehicles—trucks—gasoline electric vehicles.

ELECTRICITY.....	381—386
Its nature—units of electricity—ohm—ampere—volt—watt—electrical horse power—construction of voltmeters and ammeters.	
DYNAMOS AND MOTORS.....	387—394
Essential parts—field magnets—pole pieces—armature—commutator—brushes—type of motor used—difference between series and shunt motors— <i>motor troubles</i> —improper connections—short circuits—two motor troubles.	
STORAGE BATTERIES.....	395—418
Action of storage cell—plates—classes of storage battery—electrolyte—charging—acid hydrometers—charge indications—storage battery troubles—taking battery out of commission—the Edison battery.	
METHODS OF CIRCUIT CHANGING.....	419—430
General arrangement of the circuit—methods and circuit diagrams—two battery two motor circuit—four battery one motor combination—the controller.	
HOW TO RUN AN AUTOMOBILE.....	431—460
Knowledge required of the driver— <i>the control system</i> —throttle levers—how the throttle is operated—the spark lever—brakes—clutch—control pedals—side lever control—selector quadrants—muffler cut out valve—whistle—self starter—how to start the car—gradual and quick stop—reversing—spark control—effect of late spark—directions for shifting the gears—difficulties encountered by the beginner—condition necessary for noiseless shifting of	

HOW TO RUN AN AUTOMOBILE—
(Continued.)

gears—why gears “growl”—hints on handling the progressive system—operating the brakes—effect of locked wheels—rules of the road—driving along trolley lines—slippery rails—precaution in crossing railroad tracks—negotiating turns—“skidding”—driving at night.

OVERHAULING THE CAR.....461—476

Dissembling the car—removing the engine—disconnecting the magneto—valves—overhauling—grinding the valves—cleaning the radiator—transmission—clutch—lubrication system—steering gear, wheels, etc.—assembling—checking the valve timing—“system” in overhauling.

INDEX

A

Absolute pressure, 40.
 Accumulator, def., 395.
 Acid, pyroligneus, 65.
 Acid fumes, from battery, 430.
 test, for oils, 355.
 Adjusting, of timer, 211.
 Admission valve, ills., des., 26, 31.
 Advancing spark, 170.
 After firing, 124, 245.
 Air cooling, 44.
 fan, 53.
 system, des., 51.
 Air gap, des., 127, 179, 180, 181.
 permanent, 176.
 Air, inlet pipe, des. and ills., 113.
 pumps, ills., 361.
 Air supply, 69, 72.
 automatic control, 118.
 hand control, 117, 118.
 primary, *S₂*, 85.
 Air valve spring, adjustment, 115.
 Alcohol, denatured, des., 66.
 compared with gasoline, 66, 68.
 how obtained, 65.
 merits and use of, 69.
 tax, 66.
 Alternating current, 128.
 Amber, how electrified, 381.
 Ammeter, ills., 384, 385.
 indicates, 386.
 Ampere, def., 126, 383.
 volt, ohm, mutual relations, 383.
 Animal test for oils, 355.
 Anti-freezing solutions, 261, 262.
 Apperson, speed selector, 438.
 Arc, def., 128.
 Armature, des., 387.
 Artillery wheel, ills., des., 312, 313.
 Assembling car, 474.
 Atmospheric pressure, 40.
 Atwater-Kent battery system,
 ills., 200.
 contact maker, ills., 203.
 spark generator, ills., des., 202.

Automobile, control of, 432.
 electric, 377.
 frame, des., 305.
 growth of, 17.
 management of, 431.
 overhauling, 461-4.
 parts, 18.
 washing, 138.
 Automatic valves, des., 26.
 Auxiliary air gap, ills. and des., 181.
 Auxiliary spark gap, 257.
 Auxiliary valves, adjustment, 114.
 Auxiliary valve spring, 111, 112, 114.
 Axle, dead, des., 309.
 floating, ills. and des., 310.
 live, des., 309.
 semi-floating, ills. and des., 309.
 A-Z radiator, ills., 52.

B

Babcock electric roadster, ills., 380.
 Back firing, def., 236-7.
 kick, def., 236.
 kick, how avoided, 232, 233, 234, 236.
 pressure, 42, 439.
 Bad odors, 244.
 Baker electric, classes of, 378.
 Balancing, how done, 209, 210.
 Ball and roller bearings, 341.
 Ball bearings, ills., 342, 343, 344.
 Band brake, ills. and des., 337.
 "Barking," cause of, 245.
 Battery, care of, 416.
 charging, 141-4, 404, 407-9, 415.
 def., 131.
 discharge capacity, 405.
 dry, des., 134.
 faulty connection, 390.
 in place of magneto, 197.
 laying up, 412.

Battery—Continued.

- overhauling, 472.
 - rate of discharge, 406.
 - storage, ills. and des., 415.
 - use of, 406.
 - weak, effects of, 252.
 - weak, how indicated, 138.
- Battery and coil, connections of, 193.
- Battery, connection, diagram, 134-7.
- fumes, 430.
 - plates, changing color, 404-5, 409.
 - plates, des. and ills., 398.
 - system, ills., 200.
 - troubles, 409, 411.
- Batteries, how made, 397.
- secondary, def., 395.
- Bearings, adjustment, 345.
- ball and roller, 341.
 - ball, wear on, 346.
 - lubricant for, 345.
 - tight, 239.
 - types of, ills., 342.
- Beaumé hydrometer, des., 61.
- use of, 58, 59.
- Belt transmission, 279.
- Benzine, 57, 59, 60.
- Bevel differential, des., ills., 301-2.
- gears, ills. and des., 295.
 - gear, taking up wear, 468.
- Black lead, def., 351.
- Blister, in tire, 333.
- Block chains, des., 296.
- Body of automobile, 18.
- Body of lubricant, 349.
- Bosch high tension magneto, 200.
- ignition system, ills. and des., 194, 196.
 - spark plug, ills., 156.
- Brake, band, expanding, ills. and des., 337.
- connection with clutch, 335.
 - horse power, 39.
 - lever, how locked, 435.
 - lever, ills. and des., 286.
 - rods, bad adjustment, 239.
 - starting adjustment, 231, 232.
 - types of, ills. and des., 337.
- Brakes, 335, 434.
- adjustment, 471.
 - forms of, ills. and des., 336.
 - operation of, 450.
 - overhauling, 471.
 - use of, 339, 340.
- Break, in wiring, 204, 205.
- Breeze, carburetter, ills., des., 106.
- fuel strainer, ills., and des., 115.
- Bridge, def., 128.
- British thermal unit, 37, 39.
- Broad tire, 316.
- Brock carburetter, des. and ills., 120.
- Broken ring, how indicated, 240, 241.
- Brush contact, def., 171.
- Brushes, des., 308.
- Buick speed selector, 438.
- Buscoe radiator, ills., 52.

C

- Cadillac speed selector, 438.
- Cameron engine, ills. and des., 50.
- Cam shaft, 26.
- assembling, 465.
 - removal of, 464.
- Car, assembling, 474.
- management of, 431.
 - overhauling, 461-4.
 - starting, 441, 442.
- Carbon, in cylinder, 241-3.
- Carburetter, adjustment of, 99, 107-8.
- affected by fuel, 95.
 - alcohol, 66, 68.
 - Breeze, ills. and des., 106.
 - Brock, des. and ills., 120.
 - calculation of size, 107.
 - D. K. W., ills. and des., 122.
 - evolution of, 73.
 - freezing, 123.
 - gasoline, 66, 68.
 - Holley, ills. and des., 97, 98.
 - how connected, 72.
 - ills. and des., 69, 91, 105, 248.
 - Kingston, des. and ills., 100.
 - outlet, 105.
 - puddle, ills. and des., 96-8.
 - priming, 82.
 - requirements of, 101.
 - Schebler, ills. and des., 109.
 - selection of, 101.
 - size required, 103, 104.
 - sizes vary, 106.
 - spray, ills. and des., 71.
 - starting adjustment, 231.
 - Stromberg, des. and ills., 88.
 - surface, ills. and des., 96-8.
 - troubles, 119.
 - types, 70.
 - Willett, ills. and des., 102.
- Care of tires, 323.
- Caution, 477-8.
- signs, 459.
- Cell, action on, 140.
- def., 131.
- Cells, disconnecting, 412.
- dry, action of, 251.
 - dry, connection of, 250.
 - dry, des., 134.
 - dry, deterioration of, 138-9, 250.
 - dry, improvement of, 139.
 - dry, testing, 139.
 - of storage battery, ills. and des., 410.

Cells—*Continued.*

- recharging, 140.
- register, 251.
- storage, action of, 395, 396.
- voltage of, 135, 140.
- how connected, 135, 137.
- Centrifugal pump, des., 46, 48.
- Chadwick swivel axle, ills., des., 343.
- Chain, cleaning, 299.
- overhauling, ills. and des., 470.
- types of, 294, 296.
- why rattles, 298.
- Chamber, mixing, des., ills., 85, 86.
- Changes of speed, 447-8.
- speed gears, 275.
- speed gears, shifting, 285.
- Charge, def., 27.
- how governed, 95.
- Charging, connections, ills., 406, 407.
- battery, 401, 403, 404, 407, 408, 409.
- ills. and des., 18, 298.
- Chassis, ills. and des., 18, 298.
- of Baker electric, 378.
- Chime whistle, 439.
- Circuit changing, methods of, 419, 420-5.
- diagram, ills., 148, 197.
- Circuits, synchronous, des., 190.
- Circulating water, 44, 45, 46.
- Cleaning Chain, 299.
- Clearance, 23.
- value of, 476.
- Clincher tire, removal of, ills. and des., 321, 322, 325.
- Clutch, cone, ills., des., 264, 265, 272.
- connection with brake, 335.
- defective, 239.
- des., 263, 264.
- des. of operation, 269.
- how released, 434, 435.
- leather friction surface, 272.
- not always necessary, 264.
- taking down, 466.
- Coasting, motorcycle, 375.
- Coil, care in selection, 257.
- defective, 256.
- trouble from, 205.
- connections, ills. and des., 368.
- Coil and battery, connection of, 193.
- Coil spark plugs, for ignition, des. and ills., 176, 180, 198, 199.
- Cold weather precautions, 259, 260.
- Colors of flame, 113.
- Columbia speed selector, 438.
- Combustion, 44.
- chamber, 23, 24.
- Complete element, of battery, 414.
- Commutator, des., 388.
- Compression, def., 27, 44.
- faulty, 124, 239.
- how effected, 24.
- stroke, 29.
- Condenser, def., 165.
- Conductor, lead, 127.
- return, 127.
- Conductors, 125.
- why of copper, 126.
- Cone clutch, ills., des., 264, 265, 272.
- Clutch, removing leather, 467.
- Connecting rod, 23, 25.
- Connections, for charging, ills., 406-7.
- Contacts, types of, 171.
- Contact breaker, ills. and des., 162, 173, 174, 183.
- maker, ills. and des., 162, 172, 173, 183.
- maker, Atwater-Kent, ills., 203.
- points, material, 152.
- Controller, electric, ills. and des., 425, 426, 427.
- connections, diagrams, 428, 429.
- Rauch & Lang, ills., des., 427.
- Control levers, ills. and des., 19, 20, 285, 433.
- of automobile, 432.
- Cooling the cylinder, 44.
- Cooling surface, 51.
- Cooling system, 19, 26, 43.
- air, des., 51.
- locomobile, ills. and des., 47.
- Copper, used for conductors, 126.
- Corbin speed selector, 438.
- Cork, effect of temperature, 273.
- forms of, for cork inserts, 274.
- inserts, 272.
- method of inserting, 273.
- properties of, 272.
- Counter current, 153.
- Counterweights, 78, 79, 209, 210.
- Crank, 32.
- Crank case, 23, 24.
- Cranking, des., 19, 20, 232, 233, 234.
- Cranks, arrangement of, 209, 210.
- Crank shaft, 25.
- Creeping, of tires, 323.
- Crude oil, 56, 57.
- Current, diagram of course, 392.
- ignition, how obtained, 366.
- primary, 252.
- primary, precautions, 253.
- Current, diagram of course, 392.
- Cut out plug, 410.
- Cuts, in solid tires, 319.
- Cutting, causes of, 329.
- des., 348.
- Cycle, def., 29.
- of gas engine, 27, 275.
- Cylinder, carbonized, 241.
- cleaning, 243.
- cooling, 44.
- gas engine, diagrams, 23, 28.
- heating, 44.
- missing fire, 246.

Cylinder—*Continued.*

- pressure, 40, 41, 42.
 - section, ills., 464.
 - strokes, def., 29.
 - support of, 24.
 - water connections, 49.
- Cylinders, assembling, 463.
cleaning, 463.

D

- Dampness, effect on tires, 331.
- D'Arsonval galvanometer, 385.
- Dashboard appliances, ills. and des., 433.
- Dash equipment, ills. and des., 466.
- Dead axle, des., 309.
center, how determined, 212, 213.
- Decauville car, ills., 292.
- Denatured alcohol, 66, 67.
- Diaphragm feed, des., 76.
- Dielectric, def., 131.
- Differential, def., 301, 303.
- Direct current, 128.
- Disc feed, des., 75.
- Discharge capacity of battery, 405.
- Disconnecting cells, 412.
magneto, 462.
- Dishing, of wheels, def., 314, 315.
- Disassembling car, 462.
- Distance, relation to force, 277, 278-9.
- Distillation, des., 57.
of petroleum, 56.
of wood, 65.
- Distributor, def., 162, 163, 174, 175, 176, 215.
Pittsfield, ills. and des., 177.
- D. K. W. carburetter, ills., des., 122.
- Double chain drive, 294.
- Double ignition system, des. and ills., 199, 200, 204.
- Drive, of dynamo, 145.
of motor cycle, 370, 371.
of pump, 49.
synchronous, def., 150.
types of, 291.
- Driver, instruction of, 432.
- Driving chain, ills. and des.
- Drum and band clutch, des., 267.
- Dry battery, des., 134.
- Dry cells, action of, 251.
connection of, 250.
des., 134.
deterioration of, 138-9, 250.
improvement of, 139.
testing, 139.
- Dual ignition, 199.
- Duplex spark plugs, 176, 180.

- Dynamo, Apple, ills. and des., 133, des., 132, 145, 387, 388.
drive of, 145.
how used, 144, 146.
parts of, 387.
- Dynamo electrical generator, ills. and des., 392.

E

- Edison storage battery, des., 416.
- Efficiency, of engine, 36.
- Eisemann magneto, ills. and des., 160-1, 204.
- Electric current, def., 128.
current, how produced, 131.
roadster, Babcock, ills., 380.
trucks, use of, 379.
- Electric vehicle, failure to start, 389.
- Electric vehicles, principles of, 379.
types of, 377.
wiring plan, 419.
- Electric vehicle, motors, type of, 337.
controller, ills., 426.
- Electrical horse power, 384.
- Electrical units, 381.
- Electricity, def., 125, 381.
from storage battery, 140.
generating, 131.
- Electro magnet, def., 129.
- Electrodes, def., 131, 179.
- Electrolyte, affected by starting, 404.
action of, 395, 396.
des., 399.
how made, 140, 143.
low speed gravity, 411.
specific gravity, 142, 143.
temperature, 142, 143.
- Electron 381.
- Elmore speed selector, 438.
- Emergency brake, ills. and des., 434, 436.
- Emery, use of, 464.
- Energy, mechanical, 37, 39.
- Engine, Cameron, ills. and des., 50.
four cycle, diagram of, 38.
horse power of, 39.
hot air, 21.
internal combustion, def., 21.
motor cycle, 363, 364.
multi-cylinder, 32.
removing, ills. and des., 462.
Pope-Hartford, ills., and des., 241.
single cylinder, 32.
starting, 77, 98, 235.
steam, 21.

Engine—Continued.

- installation, Thomas, 237.
 - operation, 259.
 - pulley, emblem, ills., des., 374.
 - speed, 73, 253, 254.
 - supplies, 226.
 - troubles, 206, 207.
 - Equalizer, des., 338, 339.
 - Essex multi-feed oiler, ills. and des., 350.
 - Ethyl alcohol, 65, 66.
 - Exhaust, def., 27.
 - pressure regulator, ills. and des., 324.
 - smoke, 243.
 - stroke, 29.
 - valve, 30.
 - Exide storage cell, ills., des., 400.
 - Expanding ring clutch, ills. and des., 297.
 - Explosion, def., 27.
 - in muffler, 208.
 - weak, 124.
 - Explosive mixture, 21.
- F**
- Fan, air cooling, 53.
 - how driven, 53.
 - Fault, def., 127.
 - Faure battery, 398.
 - plate, des., 399.
 - Fedders radiator, ills., 52.
 - Feed, disc, des., 75.
 - float, des., 77, 78.
 - Fermentation, source of alcohol, 65.
 - Field, magnetic, def., 129.
 - Field magnets, des., 387.
 - "Fierce," clutch term, def., 269.
 - Fire, risk from gasoline, 63.
 - test, of oil, 357.
 - Firing, sequence of, 210.
 - First speed, 279.
 - Flame colors, 113.
 - Flash point, of oil, 42, 357.
 - Float, 74.
 - adjustment of, 108.
 - Float chamber, 74, 80, 81.
 - cleaning, 108.
 - relation to nozzle, 79, 80.
 - Float feed, ills., 74-8.
 - Floating axle, ills. and des., 210.
 - Float level, 78.
 - pin, 82, 249.
 - point, 78.
 - Floats, how made, 80.
 - objections to, 80.
 - Flooding, 120, 121.
 - Flow of current, 126.
 - Fluid, law of flow, 99.
 - Fluidity, def., 350.
 - Fly wheel, 23.
 - removal of, 473.
 - use of, 30, 32.
 - why necessary, 276.
 - Foot pedals, 20.
 - Foot pounds, 37, 39.
 - Force, feed oiler, ills., 349, 351.
 - lines of, 144.
 - relation to distance, 277-9.
 - Fouling, how removed, 259.
 - of spark plug, 258.
 - Four cycle, def., 29.
 - Four cycle engine, efficiency of, 37.
 - diagram of, 38.
 - sectional view, 22.
 - Frame, of automobile, 18, 305.
 - motor cycle, 364.
 - Franklin cooling system, 51.
 - Franklin, gasoline tank, 228.
 - roller bearings, 344.
 - speed selector, 438.
 - Freezing, 348.
 - precautions, 260.
 - of carburetter, 123.
 - of jacket water, 260.
 - Frictional contact transmission, 279, 290.
 - Fuel., 55.
 - adjustment, 72, 110, 111.
 - affects carburetter action, 95.
 - charge, proportions, 69.
 - economy, four cycle engine, 34, 37.
 - how heated, 90.
 - proportion to air, 69.
 - regulation of, 83, 84.
 - use of alcohol, 65.
 - use of kerosene, 64, 65.
 - mixture, 27, 445.
 - strainer, ills. and des., 115.
 - supply, care of, 229.
 - system, 19, 26.
- G**
- Galvanometer, D'Arsonval, 385.
 - Garage, fire risk, 63.
 - Gas, law of flow, 99.
 - Gas engine, def., 21.
 - cylinder, diagrams, 28.
 - cycle, 27, 275.
 - cycle, heat of, 41.
 - operation, 225, 226.
 - parts of, 23.
 - principles, 36.
 - sectional view, 22.

- Gasoline, 55-57.
 compared with alcohol, 66, 68.
 fire risk, 63.
 handling, 63.
 in mixing chamber, 86, 87, 88, 89.
 low grade, 121-123, 247, 248.
 merits and use of, 67.
 nozzle, level of, 77.
 obstruction to flow, 119.
 properties of, 62.
 state, def., 63, 121, 122.
 storage of, 64.
 substitute for, 227.
 supply of, 229.
 testing, 62, 123.
- Gasoline-electric vehicle, 380.
 Gasoline hydrometers, ills., des., 60.
 Gasoline tank, ills. and des., 228.
 filling, 226, 227.
- Gear, bevel, taking up wear, 468.
 differential, examination, 468.
 pump, des., 46, 47, 48.
 shifting, 442.
 shifting lever, 435.
 shifting mechanism, ills. and des., 287.
 steering, overhauling, 469.
- Gears, change speed, 275.
 shifting of, 447, 448.
 timing mark, 214.
 transmission, 279.
- General Electric rectifier, 418.
 Generating electricity, 131.
 Generator valve, des. and ills., 112.
 Glazing, des., 252.
 Gould storage battery cell, 410.
 Governor, for dynamo, 145, 146.
 Graphite, des. of, 351, 352.
 Gravity, specific, def., 400.
 Gravity circulation, 45, 46.
 Gravity cooling system, ills., 43.
 Gravity system of lubrication, 355.
 Grease, for lubrication, 229.
 use of, 352.
- Grinding valves, ills. and des., 235, 446, 464.
- Grip control, motor cycle, 369.
 Gripping, des., 271.
 Grooving, des., 348.
 Ground circuit, 127.
 electrode, des., 179.
- Gummed oil, remedy for, 260.
- H**
- Hammer vibrator, ills., des., 167.
 Hand advance, 195.
 control, 116, 118.
 Hand control, of air supply, 117.
 Handle bar grip control, ills. and des., 369.
 Hand throttle lever, use of, 433.
 Harrison radiator, ills., 52.
 Heat, carried off by water, 41.
 lost in engine, 42, 44.
 utilized by engine, 42.
- Heating, air supply, 91.
 fuel, 90, 91.
 mixture, 91.
 of cylinder, 44.
- Heavy oils, 57.
 Hertz wave, 199.
 High speed, 279.
- High tension, circuit, 181, 182.
 current, 128.
 ignition, 150, 159.
 magneto, 147, 445.
 magnetos, ignition with, 193.
 magneto, timing, 216.
 spark, 127.
- Hill oiler, ills., 362.
 Holley carburetter, ills., des., 97, 98.
 Honeycomb radiator, des., 49.
 Horse power, def., 39.
 electrical, 384.
 of engine, 39.
- Hydrometer, Beaumé, des., 61.
 Hydrometers, gasoline, ills. and des., 60.
 for testing gasoline, 62.
 ills. and des., 402.
 specific gravity, 400.
 use of, 58, 59.
 variation for temperature, 59.
- I**
- Igniters, trouble from, 206.
 Ignition, 30, 125, 198.
 affected by engine speed, 253, 254.
 by coil spark plugs, 198.
 cut out plug, 440.
 forms of, 199.
 high tension, 182.
 jump spark, 182, 212.
 synchronous, def., 190, 191, 192.
 time for, 40.
 with high tension magnetos, 193.
 with vibrator coils, des., 186, 187.
- Ignition, apparatus, overhauling, 471.
 circuit, cells necessary, 169.
 circuit, starting adjustment, 231.
 coil, overhauling, 473.
 current, 148, 149, 366.
 defect, 257.
 mechanism, 210.

Ignition system, 19, 26, 119.
 Bosch, ills. and des., 194, 196.
 low tension, ills. and des., 154.
 Perfex, ills. and des., 199.
 troubles, 201, 204, 205, 208.
 types, 150.
 Impulse, def., 27.
 Indian motor cycle, ills., 367.
 motor cycle valves, ills. and
 des., 366.
 Induced current, 130.
 Induction, 130.
 Induction coil, care in selection, 257.
 ills. and des., 254.
 primary, 152, 153.
 secondary, 163.
 Inductor magneto, des., 146, 158.
 Inlet valve, 30.
 care of, 81.
 cause of sticking, 240.
 Inflation, 329, 330.
 Instruments, for testing batteries,
 402.
 Insulated electrode, des., 179.
 Insulation, faulty, 257.
 need of, 126.
 of spark plug, 179, 180.
 Insulator, def., 128.
 Intermediate speed, 279.
 Internal combustion engine, def., 21.
 Interrupter, 163.
 Inward stroke, 30.
 Iridium for contact points, 152.

J

Jacket water, freezing of, 260.
 Joint, universal, 292, 468.
 Jump spark, 127.
 ignition, 150, 159, 212.
 system, des., 181, 182, 183.

K

Kelly-Springfield block tire, 334.
 Kerosene, 57.
 how used, 64, 463.
 Kingston carburetter, des., ills., 100.
 Kit of tools, ills., 461.
 Knocking, of engine, 207,
 in cylinder, 207.
 Knox speed selector, 438.

L

Latch, shifting lever, 436.
 Laying up battery, 412.
 Lead, used for plates, 398.
 Leaf springs, des., 306.
 Leaking, float, 121.
 piston, how indicated, 240, 241.
 tanks, 121.
 Leather, keep oil and water away,
 271.
 of cone clutch, 467.
 Lever, transmission, handling, 447,
 448.
 selective transmission, ills., 437.
 Levers, control, 20, 285, 433.
 des., 286, 287.
 management of, 288.
 throttle, use of, 432.
 Liquid lubricants, 353.
 Lines of force, 144.
 Live axle, des., 309.
 Livingston radiator, ills., 52.
 Locked wheels, 450.
 Locomobile, brakes, ills., des., 338.
 cooling system, ills., des., 47.
 speed selector, 438.
 Lodestone, des., 128, 129.
 Losses, heat, 42.
 Lost motion, how caused, 221-3.
 Low compression, des., 240.
 speed, 279.
 Low tension, circuit, 181.
 current, 128.
 ignition, 150, 152, 153, 155.
 ignition system, ills., des., 154.
 magneto, des., 147.
 spark, 127.
 system, des., 151.
 Lozier speed selector, 438.
 Lubricant, body of, 349.
 fluidity of, 350.
 for bearings, 345.
 qualities of, 42, 359.
 stability of, 350.
 use for, 347, 348.
 Lubricants, classification of, 351.
 how used, 360.
 liquid, 353.
 Lubrication, general, 229, 347.
 of motor cycle, 375.
 Lubrication system, 26, 230, 358.
 cleaning, 468.
 starting adjustment, 231.
 systems of, 355.
 Lubricator, force feed, ills. and
 des., 349.
 Lubricators, Lunkenheimer, ills.,
 360.
 Lunkenheimer exhaust pressure
 regulator, ills. and des., 354.
 Lubricators, 360.
 Lye, for cleaning, 465.

M

- Magnes lapes, Latin for magnet, 128.
- Magnet, derivation of, 128.
magnetizing of, 472.
polarity of, 130.
- Magneto, used in starting, 195.
- Magnet, winding, 130.
- Magnetic field, def., 129.
poles, def., 129.
spark plug, ills., 156.
- Magneto, arrangement of, 215.
battery used for, 197.
des., 132, 145, 213.
disconnecting, 462.
how used, 144.
speed of, 216.
timing of, 214-216.
- Magnetos, types, 133, 146.
high tension, 193.
- Make and break, ignition, 150.
spark, 127, 212.
spark plugs, 176.
- Marine use, of two cycle engine, 37.
- Marmon car, 266.
clutch, ills. and des., 266.
- Master vibrator, des., ills., 188, 189.
- Matheson multiple disc clutch, 270.
speed selector, 438.
- Maxwell transmission lever, ills., 437.
- Mechanical circulation, 46.
energy, 37, 39.
oiler, ills. and des., 359.
vibrator, ills., des., 172, 173, 185.
- Mercury arc rectifier, des., 416.
diagram, 417.
- Metal of the engine, def., 127.
- Metallic circuit, 127.
- Methyl alcohol, 65.
- Misfiring, 123, 125, 207.
how caused, 236, 252, 253, 255, 257.
- Missing cylinder, 246.
- Mixing chamber, des., ills., 85, 86.
- Mixture, constant, 92.
faulty, 124.
fuel, 92.
lean, def., 92.
lean, when necessary, 93.
poor, 247, 249.
qualities of, 250.
rich, def., 72, 82, 93, 249.
rich, when desirable, 93.
rich, why objectionable, 94.
satisfactory, 109, 110, 111.
test of, 111.
thin, def., 92.
unsatisfactory, 108.
- Motor, def., 387.
ills., 388.
armature, 387.
brushes, 388.
commutator, 388.

Motor—Continued.

- field magnets, 387.
pole pieces, 387.
operating, 389.
parts of, 387.
- Motors, serics wound, 388.
- Motor connection, ills., des., 393.
- Motor cycles, des., 365.
- Motor cycle, coasting, 375.
control, 369.
drive, ills., 370, 371.
engine, 363, 364.
frame, 364.
lubrication, 375.
road adjustment, 374.
starting of, 372, 373.
stopping, 376.
transmission, 372.
valve gear, ills., des., 367.
valves, ills. and des., 366.
wheels, 364.
- Motor drive, electric, 377.
troubles, 390, 391, 393, 394.
truck tires, ills., 332, 334.
- Muffler, des., ills., 19, 42, 244-5, 439.
explosions, 208.
- Multi-cylinder engine, 32.
- Multiple connection, 136.
disc clutch, ills. and des., 268, 269, 270.
nozzles, 84.
- Multi-unit coil, 188.
- Mushroom valves, 25.

N

- Naphtha, 56, 57.
- National steam vulcanizer, ills., 327.
- Negative pole, def., 129, 131.
- "Neutral" position, des., 287.
- Night, driving, 460.
- Non-conductor, def., 128.
- Northern car, running gear, ills., and des., 314.
- North pole, def., 129.
- Nozzle, spray, 83.
action, faulty, 113.
- Nozzles, multiple, 84.
- Number one distillate, 227.

O

- Offset float chamber, 80.
- Ohm, 126, 382.
- Ohm, G. S. German scientist, 382.

- Oil, cylinder, 230, 231.
 distillation of, 57-59.
 for lubrication, 229.
 gummed, remedy for, 260.
 how to determine quality, 354.
 quality of, 253.
 rancid, 355.
- Oiler, Essex multi-feed, ills. and des., 350.
 force feed, ills., 351.
 Hill, ills., 362.
 mechanical, ills. and des., 359.
- Oiling instructions, 361.
- Oil pumps, ills., 361.
- Oils, burning point, 353.
 classes of, 353.
 cold point, 353.
 flash and fire tests, 357.
 flash point, 353.
 heavy, 57.
 mineral, 358.
 specific gravity of, 61.
 testing, 353, 355.
 vegetable, 358.
- Oldsmobile speed selector, 438.
- Opening valve, area of, 105.
- Operation of two cycle engine, 33, 34, 35.
- Outward stroke, 30.
- Overhauling car, 461-4.
- Overload, electric, 336.
- P**
- Packard Co. progressive gear, 449.
- Packing rings, 24.
- Paraffin wax, 57.
- Parallel connection, 135, 136.
- Parts of cylinder, 23.
- Patching tire, 326.
- Pedals, foot, 20.
- Peerless cars, 204.
 speed selector, 438.
- Perfix ignition system, ills. and des., 199.
- Permanent air gap, 176.
- Petrol, def., 59.
- Petroleum, des., 55, 56.
 distillation of, ills., des., 54, 56.
 ether, 57.
 products of, ills. and des., 54.
- Pipe, air inlet, des. and ills., 113.
 sizes, table of, 107.
- Piston, des., 24.
 cleaning, 464.
 displacement, 24.
 leaky, how indicated, 240, 241.
 of gas engine, 23.
 ring, leaky, 124.
 rings, 24, 25.
- Pitting, of vibrator points, 192, 193.
- Pittsfield distributor, ills., des., 177.
 timer, ills., 171.
- Plain coil, def., 163, 164, 183.
- Planetary transmission, des., 279.
 ills., 289.
- Plante battery, 398.
 Plate, des., 399.
- Plates, battery, changing color, 404, 405, 409.
 battery, des. and ills., 398, 413.
 types, 399.
- Platform springs, ills., 306.
- Platinum, for contact points, 152.
- Plug, ignition cut out, 440.
 spark, testing, 203.
- Plumbago, def., 351.
- Pole pieces, def., 387.
- Poles, of a magnet, def., 129.
- Pope-Hartford engine, ills. and des., 241.
 lubrication system, 358.
- Poppet valves, 25.
- Positive pole, def., 129, 131.
 system, of lubrication, 356.
 valves, des., 26.
- Potential, def., 126.
- Pounding, to be avoided, 445.
- Power, def., 39.
 losses of, 239.
 plant, 18.
 stroke, def., 27, 29.
- Pre-ignition, 246.
 troubles, 206.
- Press button, use of, 288.
- Pressure, absolute, 40.
 atmospheric, 40.
 back, 42.
 cylinder, 41, 42.
 during suction stroke, 40.
 relation to volume, 40.
 regulator, ills. and des., 354.
 system, of lubrication, 356.
- Primary air supply, 72, 82, 85.
 cell, def., 131.
 circuit, 181.
 connections, 205.
 current, 128, 130, 160, 252.
 current, precautions necessary, 253.
 element, 175.
 induction coil, 152, 153.
 spark plug, 176.
 switch, 205.
 winding, 130.
- Priming carburetter, 82.
- Principles of gas engine, 36.
- Products of petroleum, ills., and des., 54.
- Progressive transmission, des., 279, 280, 281, 449.
- Prony brake, 116.
- Propeller pump, 46.
- Properties of cork, 272.

Pump centrifugal, des., 48.
 drive for, 49.
 gear, des., 47.
 propeller, des., 48.
 Pumps, types, 46.
 Puncture of tires, 325.
 Push buttons, 20.
 rod valve, ills. and des., 224.
 Pyroligneous acid, 65.

R

Radiating surface, of cylinder, 51.
 Radiator, ills., 44, 45, 228.
 cleaning, 465.
 filling, 228.
 honeycomb, des., 49.
 construction, types of, 52.
 Radius rod, des., 294, 308, 309.
 Railway tracks, 455.
 Rancid oil, 355.
 Ranier pedestal frame, ills., 311.
 Rauch & Lang controller, ills. and des., 427.
 Rectifier, general electric, des., 418.
 mercury arc, des., 416.
 Regulator, exhaust pressure, ills. and des., 354.
 Remy wiring diagrams, 184.
 Repairs of tires, 323, 327.
 Resistance, 125.
 Retarding spark, 170.
 Rheostat, 141.
 Rich mixture, 82.
 why objectionable, 94.
 Rim cutting, how caused, 328.
 Rims, care of, 331.
 Ring broken, how indicated, 240, 241.
 piston, leaky, 124.
 Rings, piston, 24, 25.
 Road adjustment, 116.
 motor cycle, 374.
 Road rules, 451-457.
 Rock oil, des., 55.
 Rod, radius, des., 309.
 torsion, des., 309.
 Roller bearings, ills., 342-345.
 chains, des., 296, 297.
 contact, def., 171.
 Rotary pump, des., 46.
 Rubber, des., 318.
 how manufactured, 318.
 Rules of the road, 451-457.
 Running down, cause of, 238.
 gear, details of, 19.
 gear, ills. and des., 18, 305, 314.
 slowly, 446.

S

Safe loads on ball bearings, table, 341.
 Safety air gap, 180.
 Schebler carburetter, ills. and des., 94, 109.
 Secondary air, 72.
 batteries, def., 395.
 cell, def., 131.
 circuit, 181, 182.
 current, 128, 130, 160.
 element, 175.
 induction coil, 163.
 spark plug, ills., 177, 178.
 winding, 130.
 wiring, faulty, 257.
 Second speed, 279.
 speed, gear shifting, 442.
 Self-starting device, des., 440.
 Seizing, how caused, 238.
 Selective transmission, des. and ills., 279-288., 449, 450.
 transmission lever, ills., 437.
 Selectors, speed, 437, 438.
 Apperson, 438.
 Buick, 438.
 Cadillac, 438.
 Corbin, 438.
 Columbia, 438.
 Elmore, 438.
 Franklin, 438.
 Knox, 438.
 Locomobile, 438.
 Lozier, 438.
 Matheson, 438.
 Oldsmobile, 438.
 Peerless, 438.
 Simplex, 438.
 Stearns, 438.
 Studebaker, 438.
 Thomas, 438.
 Toledo, 438.
 Walter, 438.
 Winton, 438.
 Semi-floating axle, ills., des., 309.
 Series battery connection, diagram, 134, 135.
 multiple connection, 135-8.
 wound motors, 388.
 Service brake, 434.
 Shaft, of gas engine, 23.
 drive, des., 291.
 drive, types, 292.
 Shifting change speed gears, 446.
 gear lever, ills. and des., 286.
 Shock, absorber, des., 307, 308.
 advantage of large wheel, 315.
 Short circuit, def., 127, 205, 390.
 circuit, how caused, 257.
 circuiting, 251, 409, 411.
 Side slipping, 459.
 Signal whistle, 439.

- Signals, for stopping, 453.
 Signs, caution, 459.
 Simms-Bosch magneto, 159.
 Simplex speed selector, 438.
 Single chain drive, 294.
 Single cylinder engine, 32.
 Spark coil, 163.
 Skidding, 468.
 Sliding contact, def., 171.
 Slings, steel, ills. and des., 462.
 Slipping, des., 271.
 Smoke, from exhaust, 243, 244.
 Snap rings, 24.
 Soapstone, use of, 352.
 Solutions, anti-freezing, 261, 262.
 South pole, def., 129.
 Spark, changing, 170.
 coils, arrangement of, 212.
 control, 175, 446.
 control, starting adjustment, 231, 232, 234.
 gap, 257.
 generator, ills. and des., 202.
 how produced, 128.
 lever, location, 434.
 management of, 444, 445.
 Spark plug, Bosch, ills., 156.
 defective, how detected, 257, 259.
 failure to work, 180.
 fouling of, 258.
 ills. and des., 156, 159.
 insulation, 179.
 secondary, def., 177.
 testing, 203.
 wiring diagram, 157.
 troubles, 258.
 Spark plugs, coil, des. and ills., 198.
 for ignition, 198.
 special required by magneto, 195.
 trouble from, 206.
 types, 180.
 Specific gravity, 400.
 bottle, 400.
 of oils, 61.
 hydrometer, 400.
 Speed, changes, 448, 447.
 control, 451.
 engine, 73.
 gears, change of, 446.
 selectors, ills., 438, 439.
 regulation of, 443.
 des., 279.
 Spinning, des., 271.
 Splash system, of lubrication, 356.
 Splitdorf master vibrator coil, ills., and des., 189.
 Spray carburetter, ills., des., 70, 71.
 Spraying gasoline, 83-89.
 Spray nozzle, 83.
 Spring, auxiliary valve, 111, 112, 114.
 Springs, des., 306.
 qualities necessary, 307.
 Spur, differential, des., 304.
 gear drive, 300.
 Stale gasoline, def., 63, 121, 122.
 Standard pipe sizes, tables of, 107.
 Starting, 82, 441, 442.
 adjustment necessary, 231.
 difficulties, 238.
 engine, 19, 77, 98, 109, 110, 235.
 misfiring, 236.
 motor cycle, 372, 373.
 Steam engine cycle, heat of, 41.
 Stearn's speed selector, 438.
 Steam vulcanizer, ills., 327.
 Steering gear, des., 18, 19.
 gear, overhauling, 469.
 wheel, ills. and des., 20, 239.
 Stopping motor cycle, 376.
 Stopping signals, 453.
 Storage, of gasoline, 64.
 Storage battery, des., 140, 141, 395, 416.
 cell, action of, 395, 396.
 cell, Exide, ills. and des., 400.
 Straight line drive, ills., des., 293.
 Stroke, def., 29.
 suction, effect of, 72.
 Stromberg carburetter, des. and ills., 88.
 Studebaker speed selector, 438.
 Suction, excessive, 72, 73.
 normal, 73.
 pressure, 40.
 stroke, 29, 72.
 Sulphation, def., 143.
 Surface carburetter, 70.
 "Sweet," def., 269.
 Swinehart flange rim, 331.
 Synchronous, def., 190.
 circuits, des., 190.
 drive, def., 150.
 ignition, ills. and des., 191, 192.
 System, in overhauling car, 476.

T

- Table, of anti-freezing solutions, 261, 262.
 of inflation of tires, 330.
 of safe loads on ball bearings, 341.
 Tank, gasoline, filling, 226, 227.
 gasoline, ills., and des., 228.
 leaky, 121.
 Tax, on alcohol, 66.
 Temperature, effect of on cork, 273.
 for vulcanizing, 327.
 of gasoline, 62.
 Testing batteries, instruments, 402.
 third speed, 279.
 Thomas engine installation, 237.
 speed selector, 438.

- Three disc cork insert clutch, ills., 273.
- Throttle, starting adjustment, 231, 231.
adjustment, 73, 77.
lever, hand, 433.
levers, use of, 432.
valves, ills., 104, 434.
- Throttling, 82, 95.
- Tickler, 82.
- Timer, construction, 170.
def., 162, 170.
Pittsfield, ills., 171.
- Timers, trouble from, 205.
- Timing, 148, 149, 169, 209.
adjusting, 211, 474, 476.
of magneto, 216.
device, care of, 253.
- Timing devices:
contract breaker, ills. and des., 162, 173, 174, 183.
contact maker, ills. and des., 162, 172, 173, 183.
distributor, des., 62-3, 174-6.
mechanical vibrator, ills. and des., 172, 173.
plain coils, 183.
primary element, 175.
secondary current, 160.
secondary element, 175.
spark control, 175.
timer, def., 162.
trembler, ills. and des., 173.
- Tire, attachment to wheel, 320.
broad, 316.
clincher, 320, 321.
pneumatic, 317, 318, 319.
qualities of, 318.
repairing, 327.
- Tires, care of, 322, 323, 329, 331, 333.
effect of dampness, 331.
for motor trucks, ills., 332, 334.
inflation table, 330.
overhauling, 471.
types of, 317, 320.
wear on, 333.
- Tire troubles, 323, 324.
- Toledo speed selector, 438.
- Tool kit, ills., 461.
- Torsion rod, des., 293, 308, 309.
- Transmission, def., 275.
forms of, 449, 450.
frictional contact, des., 290.
lever, handling of, 446-448.
levers, ills. and des., 436.
planetary, des. and ills., 289.
principles, ills. and des., 276.
progressive, des., 280, 281.
of motor cycles, 372.
selective, des. and ills., 282, 283, 284, 287, 288.
system, cleaning, 465.
theory of, 277, 278.
types, 279.
- Trembler, ills. and des., 173.
- Trolley tracks, 454.
- Troubles, with spark plugs, 258.
- Trucks, electric, 377, 379.
gasoline-electric, 377.
- Truffault shock absorber, ills., 308.
- Two-cycle, def., 29.
- Two-cycle engine, operation of, 33, 34, 35.
where favored, 37.

U

- Unispark battery system, ills., 200.
- Units, of electricity, 381.
- Universal joint, des., 291, 292.
joints, examination, 468.

V

- Valve, action, 217, 219.
admission, ills. and des., 31.
clearance, 476.
gear, des., 23, 26.
gear, motor cycle, ills., des., 367.
grinding, ills. and des., 235.
inlet, cause of sticking, 240.
late, 218.
opening, area of, 105.
push rod, ills. and des., 224.
setting, 209.
spring, air, adjustment, 115.
stems, adjustment, 475.
tappets, adjustment, ills., 475.
velocity, of mixture, 40.
- Valves, 25, 30.
admission, 26.
arrangement on cylinder, 366.
grinding of, 464.
grinding, why necessary, 446.
removal of, 463.
- Vans, electric, 377.
- Vapor, def., 89.
- Vaporization, by heat, 90.
defective, 260.
how governed, 89, 90.
- Vaporizer, des., 69, 112.
- Vehicle, electric, failure to start, 389, 390.
controller, ills., 426.
- Vehicles, electric, principles of, 379.
- Velocity, of fixture, at valves, 40.
- Venturi, principle, 99, 101.
tube, 97.
tube, effect of, 101.

Verdigris, how formed, 144.
Vibration, trouble from, 205.
Vibrator, adjusting, 168, 169, 254, 255,
473.
 failure of, 257.
 coll, ills. and des., 163-167, 185.
 coils, ignition with, des., 186, 187.
 mechanical, 185.
 points, pitting, 192, 193.
Volume, relation to pressure, 40.
Volt, def., 126, 383.
Voltage, def., 126.
Volt-ammeter, ills. and des., 382.
Volt meter, ills., 384, 385.
 indicates, 386.
 use of, 139.
Vulcanizer, steam, ills., 327.
Vulcanizing tire, 327.

W

Walter speed selector, 438.
Water, circulating, 44, 45.
 circulation, temperature, 50.
 circulation, velocity of flame, 50.
 connections, cylinder, 49.
 in carburetter, 247.
 in mixture, 247.

Water—Continued.

 jacket, 41, 44.
 supply, care of, 229, 237.
Watt, def., 384.
Watt, James, 384.
Weak battery, effects of, 252.
 explosions, 124.
 how indicated, 138.
Wear, ills. and des., 348.
Wheel, artillery, ills., des., 312, 313.
 cleaning, 469.
 large, advantage of, 315.
 steering, 20.
Wheels, comparative merits, 315, 316.
 examination, 469.
 motor cycle, 364.
 qualities necessary, 311.
 slipping, 450.
Whistle signal, 439.
Willett carburetter, ills., des., 100.
Winton lubrication system, ills.
 and des., 230.
 speed selector, 438.
Wiring break, 204, 205.
 diagrams, 168, 207.
Wood, distillation of, 65.
 alcohol, 65.
 spirit, 65.
Work, def., 277.
Working cycle, def., 29.
Wrench, adjustment of, ills., 225.
Wrist pin, 24.
 wear of, 464.

CAUTION

Automobile owners, as a rule, in discussing their costs generally name the great item of expense as being tires, and in that connection they are inclined to arraign the makers of pneumatic tires as being responsible for this condition.

These statements are based on more or less experience, and doubtless justified in part by the records of bills paid by those who buy tires. Mention is made of this common trouble in the hope that it may suggest a way of reducing the sum total of tire bills, as well as leading in the direction of safer and saner methods in driving, and in the last analysis, greater pleasure from automobiles.

Accidents will also be reduced, as well as wear and tear mentally on an owner in connection therewith. In other words, sanity in the use of the automobile is of incalculable money value which no owner should ignore: and the reverse of the proposition is an unnecessary extravagance, which, if indulged in, should not carry with it an invective against the tire manufacturer or the manufacturer of the car. In other words, the responsibility for high costs in running expenses is absolutely in the hands of the owner, or, perhaps, more directly in the hands of the driver.

Excessive speed, under all conditions, is done at high cost, which abnormal cost can only be reduced by the adoption of sane methods.

There are three prime factors responsible for short tire life:

- 1. Excessive speed, especially during the warm months;*
- 2. Changes of direction at a high rate of speed;*
- 3. Excessive and unnecessary use of mechanical brakes.*

The life of tires is considerably prolonged by avoiding the above three enemies of the pneumatic tire's longevity. So much for the direct money cost, but if these three principles be insisted upon by owners, the liability of accident will be reduced to a minimum, and all the high costs incident to property and personal damage.

The antagonism of the farmer against the automobile is mainly the result of a series of circumstances which to "the other fellow" seems like a succession of outrages. It is well for the driver of an automobile to realize that the other fellow used the highway, more or less unmolested, ever since there were highways. That, while he may feel he has pre-emption, that pre-emption goes no further than the joint use. For the driver of an automobile to assume to use more than his share of the road to make of his vehicle a menace, or at the very least a nuisance to other users, is a very natural cause for antagonism.

The users and drivers of automobiles can, by sane driving, do the larger part in accomplishing a reversal of this sentiment, and in any event only fair play will eliminate the present friction which none may truthfully deny exists.

THE AUTOMOBILE

The modern automobile represents a long series of inventions and improvements. In one way, it has a history similar to that of the railway car. At first both were devised as suitable substitutes for the horse drawn vehicle, and, as a consequence, began by following certain traditions of construction, which have proved very like hindrances to progress.

Only when the theory of railway car construction departed entirely from the models and traditions of road wagons in the adoption of the American passenger coach, did the day of real progress and comfortable travel begin. In similar fashion, many of the greatest constructional problems of automobiles may be most readily solved, both for the designer and the operator, in recognizing the fact that they resemble horse carriages in no other respect than that both have similarly appearing bodies, mounted on four wheel frames, and run on ordinary highways.

Several things have contributed to reduce the cost of an automobile and insure its reliability. The enormous number of cars that are built allows them to be sold at very moderate prices. The quantity makes each individual part of the car cost less, and the use of interchangeable methods in manufacturing gives an owner any repair part at a very small price.

Engineers have "learned" materials for each part; steel makers have co-operated with them to produce special grades of steel suitable for automobile use, thus securing lightness combined with strength and durability.

Answers Relating to the Automobile

Ques. What are the principal parts of an automobile?

Ans. 1, a wooden or metallic body containing the seats, and 2, a chassis, which includes the frame, the power plant, the running gear, and the steering gear.

Chassis is a word introduced into popular favor with the automobile. It is from the French *chassis*, meaning a frame. In automobile construction, a rectangular framework of iron or steel directly supported on springs attached to the front and rear axles.

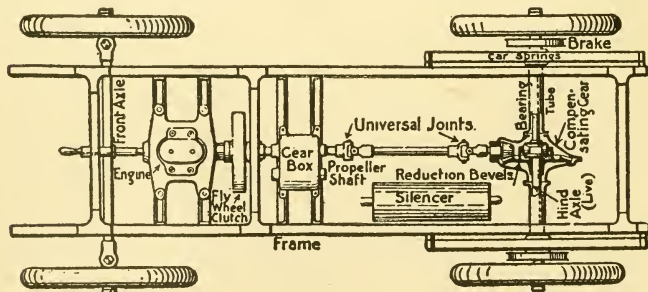

Fig. 1—Chassis of an automobile. Plan showing arrangements of the parts of which the chassis is composed. They are, the frame, the power plant, the running gear, and the steering gear.

Ques. Describe the power plant of a gasoline automobile.

Ans. The engine, as shown in fig. 1, is attached to the forward end of the frame, and on account of the nature of the gas engine cycle, power is applied in propelling the car: 1, through a clutch, 2, a gear set containing a series of spur gears for altering the speed of the engine with respect to that of the rear wheels, 3, a shaft drive with a universal joint at each end or a jack shaft and chain drive,

4, a differential gear which allows the rear wheels to rotate at different speeds on a curve, 5, a rear drive axle, or sprockets through which the power is finally delivered to, 6, the rear wheels.

Ques. What is necessary for the operation of the engine?

Ans. The following accessories: 1, fuel system, 2, ignition system, 3, cooling system, 4, muffler, and 5, the control levers.

Ques. What is understood by the running gear?

Ans. This includes: 1, the springs which absorb shocks due to uneven roadway, 2, the axles, 3, wheels, and 4, the steering gear.

Ques. What other means are provided for absorbing shocks besides the springs?

Ans. The wheels are fitted with pneumatic, or solid tires, of sufficient elasticity to reduce considerably the vibration to be taken care of by the springs.

Ques. How is the steering gear ordinarily constructed?

Ans. The steering wheel and shaft are carried by a column inclined at a convenient angle in front of the driver's seat, and supported at its base by the frame. Motion is transmitted to the two forward wheels through a worm on the lower end of the steering shaft and connections. The forward wheels turn on studs which are pivoted at each end of a rigid axle tree, so that the motion transmitted from the steering wheels turns the studs through parallel angles, thus enabling, when desired, the car to travel in a curved path.

Ques. How is the engine started?

Ans. By "cranking," that is, giving the starting handle one or two turns by hand; the starting handle consists of

a crank having a clutch which engages with the forward end of the engine shaft. A spring pushes the clutch out of engagement when not pressed toward the engine in cranking.

Ques. How is the motion of the car controlled on the roadway?

Ans. By a series of control levers, mounted on the frame at the driver's side, and on the steering wheel or column; also by several foot pedals.

Ques. What levers are at the side of the car?

Ans. The inner lever for shifting the transmission gears, and the outer lever for operating the emergency brake.

Ques. What levers are on the steering wheel or column?

Ans. 1, the spark control lever, and 2, the hand throttle lever.

Ques. Explain the use of the foot pedals.

Ans. The left pedal releases the clutch, the middle pedal applies the **service** brake, and the right pedal operates the throttle.

Ques. Are there any other control devices operated by the foot?

Ans. Sometimes push buttons are provided to cut out the muffler, and to operate an exhaust whistle.

THE GAS ENGINE.

The term "gas engine" is usually used to designate the internal combustion engine without regard to whether it operates with gas or liquid fuel. The purpose of all engines is to convert **the heat** generated by the combustion of the fuel **into work**. Existing engines may be divided into two classes according as the combustion takes place outside or inside the working cylinder.

In the first named class, the heat of combustion is transmitted by conduction externally to a working substance or medium, which carries the heat into the cylinder and there is transformed into work. The most common example of this class is the steam engine; another example, though in limited use is the hot air engine.

In the second class, the fuel is introduced into the cylinder in the form of an **explosive mixture**, and there is ignited; the heat generated by the combustion is transformed into work, acting directly on the piston—hence the name, "internal combustion engine."

The important connection between the gas engine and the automobile justifies the following suggestions relating to its construction and workings.

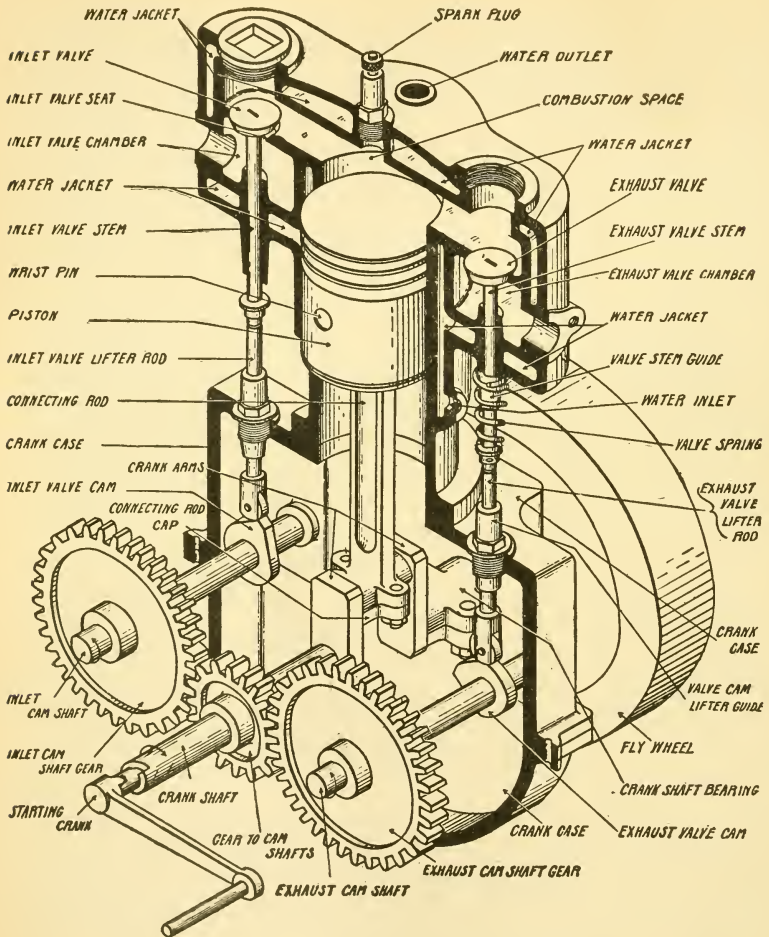

Fig. 2.—Sectional view of a four cycle gas engine showing the valve gear and other working parts. Both inlet and exhaust valves are mechanically operated. The location of the valves diametrically opposite each other, requires a separate cam shaft for each. These cam shafts are geared to the engine crank shaft, and they make one revolution to every two of the engine. When the inlet valve is operated by a spring and the engine suction, only one cam shaft is necessary, as illustrated in fig. 7.

Answers Relating to the Gas Engine

Ques. Name the parts of a gas engine.

Ans. A gas engine is composed of stationary and working parts.

The stationary parts are: 1, the cylinder, and 2, crank case; the working parts are: 1, the piston, 2, connecting rod, 3, shaft, 4, fly wheel, and 5, valve gear.

Ques. Describe the cylinder.

Ans. The cylinder of a gas engine is open at the end toward the crank, and closed at the opposite end, save for inlet and exhaust ports, which are opened and closed by valves.

Ques. What is the combustion chamber?

Ans. This corresponds to the clearance space in a steam engine cylinder, but its object is to provide a small space into which each charge of the fuel mixture may be compressed to considerable pressure on the compression stroke of the piston, and then ignited. Together with the volume displaced by the piston, it forms the total content of the cylinder as measured when the piston has reached the end of the outward stroke.

Ques. What other name is given to the combustion chamber?

Ans. It is sometimes called the **clearance**, as it is the space which is not displaced by the piston on its inward stroke.

Ques. What does the size of the combustion chamber determine?

Ans. The degree of compression; the smaller the chamber in proportion to the piston displacement, the higher the pressure to which the mixture is compressed.

Ques. How is the cylinder supported?

Ans. By the crank case, which is a closed box-like structure, made up of an intermediate piece to which the cylinder is attached, and a lower piece which retains the oil.

Ques. Describe the piston.

Ans. It consists of a cylindrical box of proper size to slide back and forth in the cylinder bore, and is of the type known as "trunk piston." This form of piston performs the duties of both piston and cross head. The piston is single acting, that is, it is acted upon by the power on one face only. To prevent leakage, several grooves are cut in its circumference to receive packing rings, the type generally used being known as "snap rings."

Ques. How is the piston attached to the connecting rod?

Ans. The upper end of the connecting rod is pivoted to a "wrist pin," which is inserted in the piston through a hole bored through its central diameter. The wrist pin is retained in place by two set screws.

Ques. Describe the construction of the piston packing rings.

Ans. They are made from a pipe shaped casting, which is turned in a lathe to an outer diameter slightly larger than the cylinder. The inner circumference is then turned from another center, and the ring cut off and split at the thinnest section. Enough metal is removed at the split section so that the ring may be slightly com-

pressed and again turned externally to the diameter of the cylinder while compressed. The latter operation causes the ring to bear evenly against the cylinder walls, thus making a tight joint.

Although formed of a brittle substance, piston rings have considerable elasticity, being capable of opening sufficiently to be slid over the outer diameter of the piston, and to "snap" back into the grooves.

Ques. What is the use and construction of the connecting rod?

Ans. It transforms the to and fro motion of the piston into rotary motion and transmits the thrust or power impulse of the piston to the shaft. The connecting rod is usually of rectangular or I shaped construction, and has an adjustable bearing at each end. One end is pivoted to the piston by the wrist pin, and the other end to the shaft by the crank pin.

Ques. Describe the crank shaft.

Ans. This is formed from a solid steel forging, and consists of a central cylindrical piece, from which radiate one or more center cranks, corresponding to the number of connecting rods. The order of cranks depends upon the type of the engine.

Ques. What kind of valves are used on a four cycle engine ?

Ans. Poppet or mushroom valves. These consist of metal discs beveled around one face, so as to fit into a countersink in the port; they are carried upon spindles.

Ques. How many valves are necessary ?

Ans. An admission or inlet valve, and an exhaust valve for each cylinder.

Ques. Name the two types of admission valve.

Ans. The automatic, and the positive or mechanically operated valve.

The automatic inlet valve, operated by suction of the piston against the tension of a spiral spring, has been extensively used, but has been largely replaced by the positive type. The reasons for this change are that the automatic valve often sticks with gummed oil on its seat; that the spring tension may vary, thus changing the fuel pressure in the cylinder; that it is noisy; that its operation on high speed engines is unreliable. As against these defects, the positive inlet valve possesses the advantages of opening and closing as desired, without noise or sticking and of giving the same amount of opening at both high and low speeds. The exhaust valve is always operated mechanically.

Ques. Describe the valve gear.

Ans. The valve stem is made of sufficient length to extend down into the crank case; it enters through a bushing which serves as a guide. Attached to the end of the stem is a roller bearing, which rides on a cam attached to the cam shaft. The latter is geared to the crank shaft in such proportion that it makes one revolution to every two of the crank shaft. By means of a spring, the roller bearing is held in contact with the cam.

Ques. Are two cam shafts necessary ?

Ans. The valves may be operated from a single cam shaft when they are located on one side of the cylinder; when the valves are on opposite sides, two cam shafts are needed.

Ques. What is necessary for the operation of a gas engine ?

Ans. The fuel, ignition, cooling, and lubrication systems.

A defect in any of these will affect the operation of the engine, hence it is desirable to clearly understand the principles involved in the working of these several systems, as later explained.

THE CYCLE OF A GAS ENGINE

The term "cycle," as applied to an engine, is defined as a **series of events which are repeated in regular order, constituting the principle of operation.** These several events comprise the transformations which take place in the working medium, or, with reference to the gas engine, the distribution and behavior of the fuel mixture in passing through the engine.

The gas engine derives its energy from the heat, generated by the combustion within its cylinder, of a **mixture of fuel** in the form of a gas or spray mingled with air in proper proportion to form an explosive.

The mixture is admitted to the engine intermittently, and the amount supplied at each admission is known as the **charge.**

The combustion of each charge takes place under pressure attained by **compression**—a result of the inward movement of the piston after the charge is admitted and all valves closed.

The effect produced by igniting the mixture after compression is commonly called an **explosion**, which is simply a quick burning or rapid combustion of the mixture.

This sudden explosion causes a high degree of heat within the combustion chamber, resulting in considerable initial pressure, and gives to the piston an **impulse**, which decreases in intensity while the piston advances to make the **power stroke**, by reason of the expansion of the gases.

The products of combustion are finally **exhausted** from the cylinder.

Expressed briefly, the cycle of a gas engine embraces: 1, the admission of the charge into the cylinder, 2, its compression, 3, ignition, 4, combustion, 5, expansion therein, and 6, the subsequent exhaust of the products of combustion.

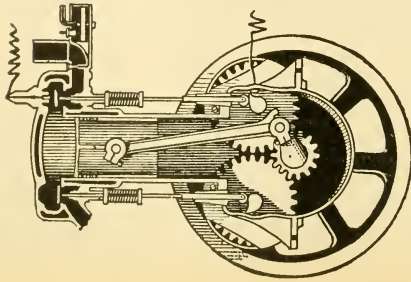

FIG. 3

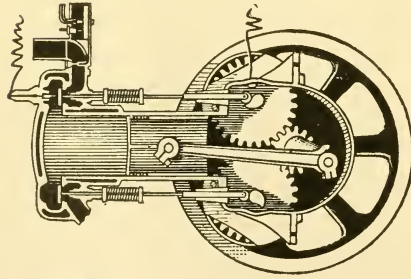

FIG. 4

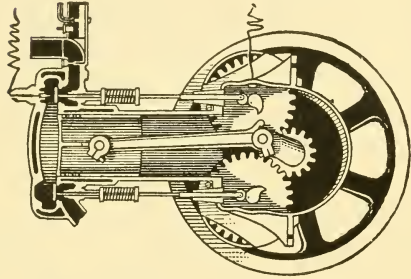

FIG. 5

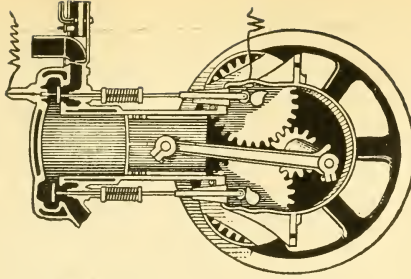

FIG. 6

FIGS. 3 TO 6.—Sectional diagrams through a single cylinder of a gasoline Engine, showing the four successive stages in the four cycle working. In these diagrams both the inlet and exhaust valves are positively operated from cams on secondary shafts. The cam shafts, as shown, being on a two to one reduction, turn half as fast as the main shaft. Fig. 3 shows the beginning of the compression stroke, all valves being closed. Fig. 4 shows the beginning of the firing stroke, when, as seen, the inlet valve is held open. Fig. 5 shows the beginning of the exhaust stroke, all valves being closed. Fig. 6 shows the end of the firing stroke and the beginning of the exhaust, the exhaust valve being open. The view of the engine is that seen when looking toward the front of the vehicle. The fly wheel rotates clockwise; the cam shafts counter-clockwise.

In the operation of a gas engine, the number of strokes required to complete the cycle varies with the type of engine. For automobile propulsion, the cycle is usually extended through four strokes, although in a few instances it is completed in two strokes. Engines of these types are known respectively as **four cycle** and **two cycle**.*

The Four Cycle Engine

The four cycle engine, although more bulky than the two cycle engine, and requiring twice the number of cylinders for equal turning effect, is almost universally used for propulsion of automobiles; it has some advantages over the two cycle engine, which have more than offset its undesirable features, and caused it to come into general favor. Among the advantages which may be mentioned are: efficiency, flexibility, adequate admission at high speeds, higher degree of expansion, and more efficient exhaust.

Answers Relating to the Four Cycle Engine

Ques. Name the four strokes comprising the working cycle of the four cycle gas engine.

Ans. 1. The suction, 2, compression, 3, power, and 4, exhaust strokes.

Ques. Describe what takes place during each stroke.

Ans. During the suction stroke the piston moves outward and draws in a charge of the fuel mixture. The following inward stroke compresses the charge into the combustion chamber; just before the end of this stroke the charge is

*NOTE—These terms have been criticised by some as incorrect; they are conveniently and properly applied to the gas engine when considered as abbreviations for four stroke cycle, and two stroke cycle.

ignited, which causes a rapid rise of pressure, and subsequent expansion of the products of combustion during the next, or power stroke. The expanded gases are expelled from the cylinder during the return, or exhaust stroke of the cylinder.

Ques. Name the outward and inward strokes.

Ans. The **first** and **third** are outward, and the **second** and **fourth** inward, that is, the piston moves away from the combustion chamber during admission and impulse, and approaches it during compression and exhaust.

Ques. How often does the piston receive an impulse?

Ans. Once in every two revolutions.

Ques. Describe the action of the valves during the cycle.

Ans. During admission, the inlet valve remains open, and the exhaust closed; during the compression and power strokes, both valves remain closed; exhaust takes place with the inlet valve closed, and exhaust open.

Ques. When does ignition take place?

Ans. At a variable time, near the end of the compression stroke depending upon the speed and load.

Ques. Why before the end of the compression stroke?

Ans. So there will be time for the pressure due to combustion to build up and thus secure a high initial pressure at the beginning of the power stroke.

Ques. What means are provided to keep the engine in motion during the three non-power strokes of the cycle?

Ans. A heavy fly wheel; this receives sufficient momentum during the power stroke to keep the engine going at approximately uniform speed during the period between impulses.

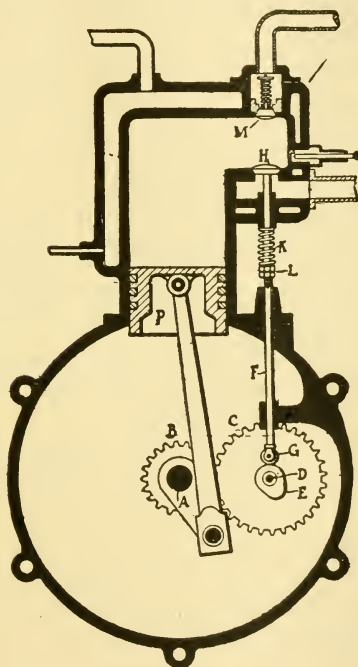

Fig. 7.—Sectional view of a four cycle gas engine with automatic admission valve. This valve M is automatically opened by the suction of the engine. The exhaust valve is mechanically opened when the cam E revolves and raises the roller G, which is on the bottom of the lifter rod F. The rod F extends upward and rests against the bottom of the stem of the valve H, although between the two or at their point of contact are nut and locknut L, for lengthening or shortening the lifter F, and so to vary the time of opening or closing of the valve. The spring K is compressed or squeezed together when the valve is opened, and immediately the cam E travels around and allows the roller G to fall; this spring exerts its pressure and closes the valve.

Ques. What objection is there to a single cylinder engine?

Ans. The weight and size of the fly wheel must be considerable on account of the prolonged pauses between impulses; by reason also of the large size piston necessary, there is considerable vibration.

Ques. How is this overcome?

Ans. By the use of several small cylinders in place of a single one of large size.

Ques. What is this arrangement called?

Ans. A multi-cylinder engine.

Ques. How many cylinders are used on automobile engines?

Ans. Usually four or six in the medium and large size cars; for those of small size there are sometimes only two, and in rare instances, one.

Ques. Explain the action of a multi-cylinder engine in overcoming the objection to a single cylinder.

Ans. The heavy impulse of the single cylinder engine may be divided into several small impulses by working a number of small cylinders from one shaft. In order to reduce vibration, and secure a better turning effect, the cranks are so placed that the several impulses occur at different times. A small fly wheel then suffices to secure approximately uniform rotation.

The Two Cycle Engine

The two cycle engine is used, to a limited extent, for automobiles; the essential difference between it and the four cycle type is that the four operations of admission, compression, impulse, and exhaust, comprising the working cycle, are performed in one revolution instead of two.

There is, then, one impulse for each revolution. From this, it follows that the weight is much less than that required for the four cycle engine. The necessary mechanical features for two cycle operation are as follows:

1. An enclosed crank case fitted with a valve arranged to open and admit fuel mixture at the front of the piston, on the inward stroke.
2. Inlet and exhaust ports located near the extreme outward position of the piston, so that they will be uncovered during the outward stroke.
3. A by-pass tube connecting the interior of the cylinder with the crank case, so as to admit the charge at the proper point in the cycle.

Answers Relating to the Two Cycle Engine

Ques. In the operation of a two cycle engine, what occurs during the first stroke?

Ans. The piston moves inward and draws in a charge of the explosive mixture into the enclosed crank case; during this operation the charge previously admitted to the cylinder is compressed and ignited as the piston nears the end of the stroke, as shown in fig. 8.

Ques. What occurs during the second stroke?

Ans. The pressure caused by the explosion of the charge drives the piston outward, and slightly compresses the mixture drawn into the crank case during the previous stroke, as in fig. 9. Near the end of this stroke the piston uncovers the exhaust port and the burnt gases are exhausted. During the remainder of the stroke the piston uncovers

the admission port, as in fig. 10, and the new charge, previously compressed in the crank case, is admitted to the cylinder, being deflected upward to the head end of the cylinder by a screen or "deflector plate" set in the end of the piston.

The "inrush" of the new charge helps materially to clear the cylinder of the burnt gases from the previous charge. The object of the deflector plate is to prevent the entering charge passing out through the exhaust in place of the burnt gases.

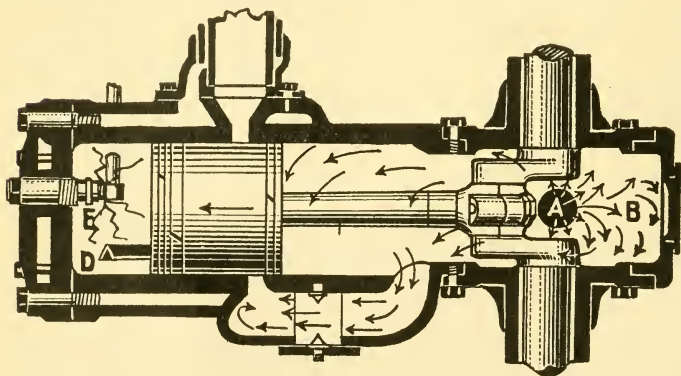

Fig. 8.—The two cycle engine: first stroke. The inward stroke of the piston induces a charge of the mixture at A into the crank case B, and compresses the previously admitted charge into the cylinder D; the subsequent ignition takes place at E.

Ques. What advantages has the two cycle engine over the four cycle?

Ans. Less weight, and the absence of poppet valves with their springs, stems, push rods, and cam shafts, thus effecting a more simple construction. Since the frequency of impulses is greater, a better turning effect is secured.

Ques. In what respect does the four cycle engine excel?

Ans. Fuel economy.

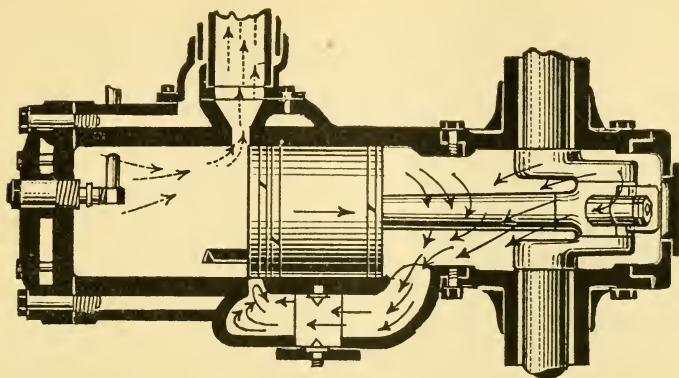

Fig. 9.—The two cycle engine: first part of second stroke. The outward stroke of the piston uncovers the exhaust port, thus releasing the burnt gases in the cylinder, and simultaneously compressing the previously admitted charge in the crank case.

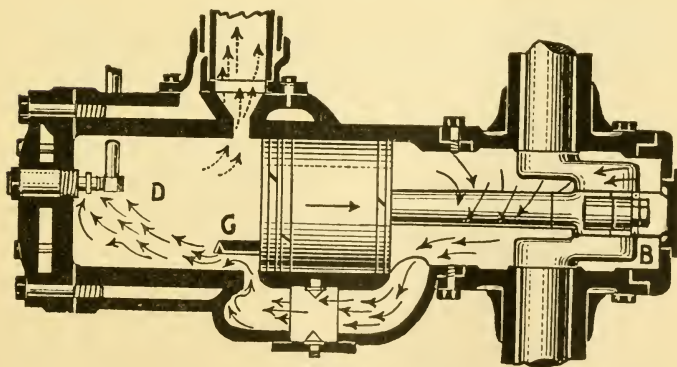

Fig. 10.—The two cycle engine: end of the second or outward stroke. The gases compressed in the crank case are admitted to the cylinder space, D, through the open inlet port, and sometimes past the screen or deflector, C. The passage between the cylinder and the crank case is controlled by a butterfly valve, which here, as in figs. 8 and 9, is shown open.

BRIEF OUTLINE OF GAS ENGINE PRINCIPLES

The gas engine derives its power or energy from the heat generated by the combustion, within its cylinder, of a mixture of gas and air in proper proportion to form an explosion.

As compared with the steam engine, the gas engine is more bulky and heavier on account of the intermittent nature of its working cycle. In operation, there are four impulses of the steam engine to one of the four cycle gas engine, hence, for equal power, its piston area must be four times that of the steam engine per pound of mean effective pressure.

Answers Relating to Gas Engine Principles

Ques. Define "efficiency" as applied to the gas engine.

Ans. The efficiency of a gas engine is the proportion of heat turned into work as compared with the total heat produced by combustion.

Ques. Does this represent the actual efficiency of a real engine?

Ans. No, there are various losses in operation which cause the actual or **mechanical** efficiency to be less than the **thermal** or **theoretical** efficiency as defined above.

Ques. How is it known that heat "can be turned into work?"

Ans. From experiments of Joule and others, it has

been demonstrated that heat and mechanical energy are mutually convertible in the proportion of about 778 foot pounds for the British thermal unit.

Ques. Why is the four cycle engine more economical than the two cycle type?

Ans. With the cycle extended to four strokes, there is more time for admission and exhaust; since these events take place at separate intervals, no chance is given for any of the charge to escape past the exhaust valve while open. Owing to simultaneous admission and exhaust in the two cycle engine, **pre-release** of the burnt gases must take place earlier than in the four cycle engine, resulting in a loss of power which is avoided in the latter. The inefficiency of admission and exhaust of the two cycle engine becomes more marked at high speeds.

The successful operation of the two cycle engine at high speeds will depend on adequate provision for rapid exhaust. A prominent gas engine authority remarks:

“The two cycle engine, at best, is the next thing to an impossibility.” By this statement, he means that the act of admitting inflammable fuel mixture into the cylinder, already filled with flaming gas, without igniting it, involves something closely approaching a contradiction in physical conditions.

Were it not for the fact that the burning gases actually exhaust faster than the new mixture is admitted under impulse of their inherent expansion, the ignition of the new charge would seem to be nearly inevitable.

By deflecting the incoming mixture to the rear end of the cylinder, it follows the rapidly expanding exhaust, coming into contact with it only when the expansion has so far reduced the temperature that the danger of pre-ignition is averted.

Ques. For what service is the two cycle engine extensively used?

Ans. For marine use, especially to propel boats of small size.

Ques. Why is this?

Ans. On account of its light weight, simplicity, and small space, as well as low cost of construction.

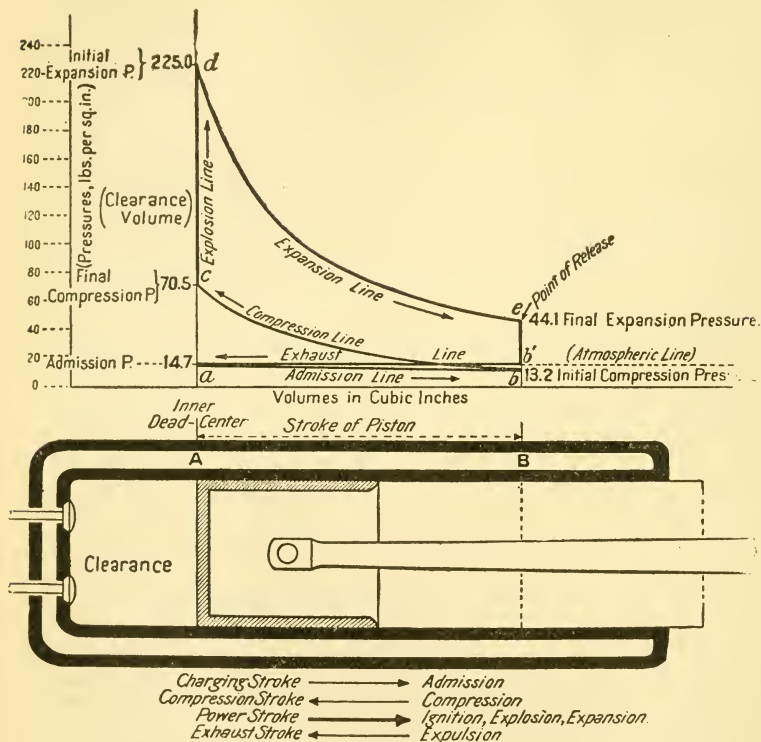

Fig. 11—Theoretical diagram of a four cycle engine. The assumed values for temperatures, volumes, and pressures, however, do not correspond to the maxima and minima of such as may be derived from theoretical computations, but represent values which are a fair average of those occurring in the cylinder of a gas engine, operating under actual conditions. The cycle is represented in the diagram as follows: 1st stroke (outward) admission of charge, line ab; 2nd stroke (inward) compression of charge, line bc, and ignition, line cd; 3rd stroke (outward) expansion of the ignited charge, line de, and release of the products of combustion, line eb'; 4th stroke (inward) exhaust of the products of combustion, line b'a.

Ques. What is a British thermal unit?

Ans. That quantity of heat required to raise the temperature of one pound of pure water 1° Fahr., at or near 39.1° Fahr., the temperature of maximum density.

Ques. What is a foot pound?

Ans. The amount of work or energy expended in raising a weight of one pound, one foot, or in overcoming a pressure of one pound through a distance of one foot.

Ques. What is power?

Ans. The rate at which work is done. It is the quotient of work divided by the time in which it is done, thus:

$$\text{Power} = \frac{\text{work}}{\text{time}} \text{ or } \frac{\text{pounds x distance}}{\text{minutes}}$$

Ques. What is one horse power?

Ans. 33000 foot pounds of work done in one minute.

Ques. On what does the horse power of a gas engine depend?

Ans. There are several factors: 1, the mean effective pressure on the piston (in pounds per square inch,) 2, the area of the piston (in square inches), 3, the stroke (in feet), and 4, the number of power strokes per minute. The product of these factors divided by 33000 will give the indicated horse power.

Ques. Does this represent the true power of the engine?

Ans. No, it does not take into account the friction of the engine which may amount to 10% or more.

Ques. What is brake horse power?

Ans. The actual power delivered to the shaft as determined by making a brake test. It is equivalent to the

indicated horse power less the power absorbed by the friction of the engine.

Ques. What is the pressure within a gas engine cylinder during the suction stroke?

Ans. About one pound less than the pressure of the atmosphere.

Ques. Why is this?

Ans. A certain degree of suction, or pressure reduction, is necessary to overcome the frictional resistance encountered by the incoming charge as it flows through the inlet manifold, and passages.

Ques. What is the velocity of the mixture flowing through the valves in a well designed engine?

Ans. From 4000 to 5000 feet per minute.

Ques. What is the pressure of the atmosphere?

Ans. About 14.7 pounds **absolute**, at sea level, that is, 14.7 pounds measured from the zero of a perfect vacuum. This is equal to zero pressure as measured on a steam gauge which only measures pressures above the atmosphere.

Ques. How does a gas act when it is compressed?

Ans. Its **absolute pressure for any degree of compression is approximately inversely proportional to its volume.**

Example: if the volume be reduced to half, the absolute pressure in the combustion chamber will be approximately doubled.

Ques. Why does ignition occur in the combustion chamber before the end of the compression stroke?

Ans. Because combustion requires time; if combustion begins at the proper instant before the completion of the compression stroke, the maximum pressure will be

attained at the beginning of the power stroke. This is desirable: 1, to avoid loss of power, and 2, to insure sufficient reduction of the temperature of the gases at the opening of the exhaust valve to prevent injury to the latter.

Ques. What conditions prevail within the cylinder during the power stroke?

Ans. At or near the beginning of the power stroke the maximum pressure due to combustion is reached; the temperature at this point is excessive, being 2000° Fahr., or even more. As the piston advances, the gases expand, and both pressure and temperature fall; near the end of the stroke the exhaust valve opens and the pressure at this point drops almost to that of the atmosphere.

Ques. How is operation possible with such high temperature as 2000° Fahr.?

Ans. The combustion chamber and cylinder are surrounded with a jacket through which cooling water circulates. This prevents the temperature of the cylinder walls and working parts rising beyond proper limits.

Ques. What loss results from cooling the cylinder?

Ans. Considerable heat is absorbed and carried off which otherwise might be converted into work.

The heat carried off by the cooling water represents the greatest of the several losses, being about 50 per cent. of the total heat received by the engine. This, unfortunately, cannot be avoided because, without cooling the cylinder, the parts would become red hot in a few minutes, rendering operation impossible.

Ques. How does the maximum temperature of the gas engine cycle compare with that of the steam engine?

Ans. It is about four times higher.

Ques. What quality should a lubricant possess in order to withstand the high temperature within the gas engine cylinder?

Ans. The "flash point" of the lubricant should be sufficiently high so that the latter will not ignite.

Ques. What conditions prevail during "exhaust?"

Ans. The pressure within the cylinder is somewhat higher than that of the atmosphere on account of the frictional resistance encountered by the gases in passing through the exhaust manifold and muffler.

Ques. What is the effect of this excess pressure?

Ans. It represents so much back pressure which opposes the motion of the piston and results in a direct loss.

The loss is due chiefly to the muffler, as its many and tortuous passages offer considerable resistance to the escape of the gases. For this reason, the muffler is usually omitted in speed contests in order that the engine may deliver its full power. When a muffler is used, a "cut out" valve is usually provided, so that full power may be obtained when required, as in ascending a hill.

Ques. What other loss occurs during exhaust?

Ans. The gases are expelled from the engine at a high temperature thus considerable heat is carried off.

The distribution of heat in a gas engine is about as follows:

Heat transferred into useful work.....		17%
" " to the cooling water....	52%	
" lost in the exhaust gases.....	16%	
" " by conduction and radiation....	15%	
	83%	83%
		<u>100%</u>

The above figures are quoted from Thurston's work on "Heat as a Form of Energy," and represent fairly the distribution of heat in the best forms of gas engine.

COOLING SYSTEMS

As the cylinder of a gas engine is an explosion chamber, that is, a furnace wherein the fuel is burned, and the explosions are very frequent, it is necessary to adopt some means to cool the cylinder walls. If the cylinder were not cooled

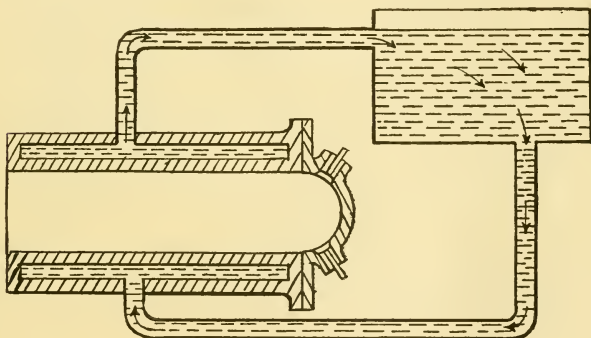

Fig. 12.—Diagram of a gravity water circulation system for a gas engine cylinder. As indicated by the arrows, the water from the tank enters the jacket of the cylinder at the lowest point, and being there subjected to the heat of the cylinder walls, rises to the level of the tank water; thus maintaining a continuous circulation.

in some way, it would get red hot, lubrication under such conditions would be impossible, and the casting would be destroyed in a short time.

In addition, the temper would be taken out of the valve springs, the spark plugs would possibly crack, and the incoming charge become so rarefied as to seriously impair the power of the engine.

Although a cooling system is a necessity, for the reasons stated above, it always causes a loss by absorbing a part of the heat units generated by the combustion of the fuel, thus reducing the efficiency of the engine.

Answers Relating to Cooling Systems

Ques. What two events of the working cycle cause the cylinder to heat?

Ans. Compression and combustion.

Ques. What two methods are used to cool the cylinder sufficiently for satisfactory working?

Ans. 1. By a jacket of circulating water, and 2, by induced air currents.

Ques. How is a water jacket formed?

Ans. A thin space around the cylinder is provided for the water by an outer casing of metal, either cast with the cylinder, or attached as in the case of a sheet copper outer casing.

Ques. What becomes of the circulating water after absorbing heat from the cylinder?

Ans. It passes off to the radiator where it is cooled; it is then used over again, circulating continuously around the cylinder and through the other parts of the cooling system.

Ques. Is this operation attended by any loss?

Ans. The heat absorbed by the water causes it to evaporate, and even in some cases to boil. The supply, therefore, must be replenished from time to time.

Ques. How is the water kept in circulation?

Ans. By gravity, or by mechanical means.

Ques. Describe the gravity method?

Ans. In accordance with the laws of liquids, water expands as its temperature increases, the heated layers, therefore become lighter and rise while the cool layers

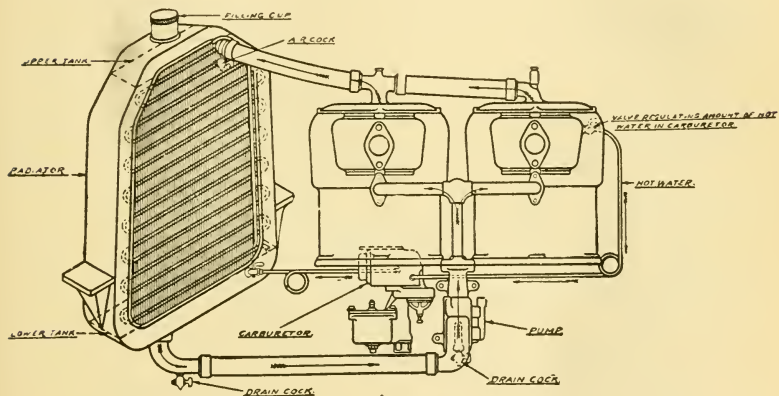

Fig. 13.—An example of a radiator and water cooling system with pump circulation. The cooling is assisted by a fan geared to the engine which induces a current of air through the radiator when the car is standing.

descend. A circulation or movement of the water is thus established.

Ques. What objections are there to the gravity method of circulation?

Ans. The motive force which keeps the water in motion is very slight, hence the flow is slow and easily stopped by any foreign matter or obstructions which may become lodged in the passages.

Ques. What advantage does the gravity system possess?

Ans. Simplicity.

Ques. How is circulation induced by mechanical means?

Ans. By force under impulse as from a pump.

Ques. What types of pump are in general use for this purpose?

Ans. The rotary, the gear, the centrifugal, and the propeller pump.

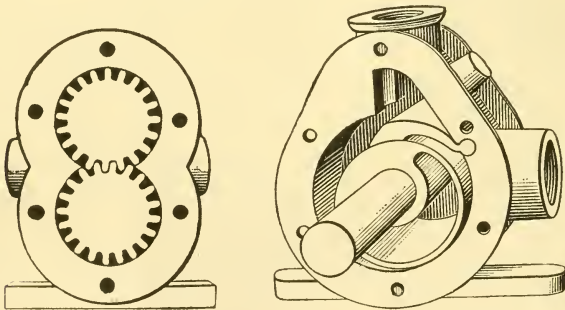

Figs. 14 and 15.—Two types of circulating pump for use in the water cooling system of gas engines.

Ques. Describe a rotary pump.

Ans. This consists of an eccentric rotating on a shaft, and enclosed in a cylindrical casing provided with inlet and outlet connections. The casing is of such diameter that the eccentric revolves tangentially with the inner cylindrical surface. The latter is cut away between the inlet and outlet to give room for the vibration of a **partition piece** which is hinged at one end, and which bears against the circumference of the eccentric at the other

end. In operation, the eccentric working with the partition piece displaces a quantity of water at each revolution.

Ques. What is the construction and operation of a gear pump?

Ans. It consists of two rotary gears which are in mesh. These are enclosed in a closely fitting chamber, to prevent

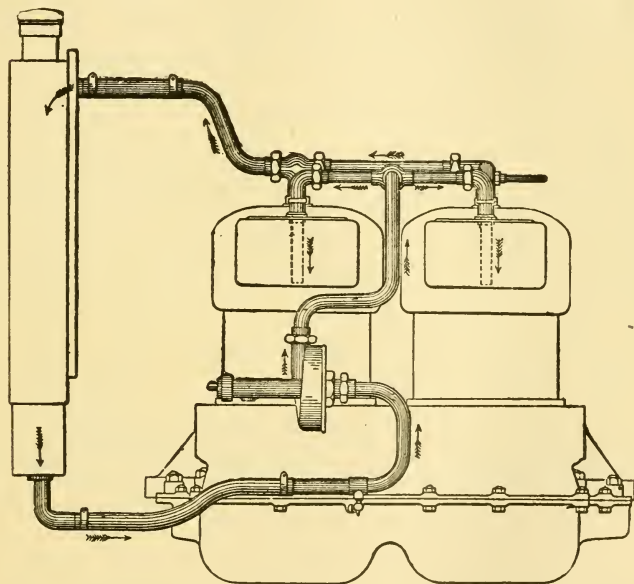

Fig. 16.—The Locomobile cooling system. The cooling water is circulated by a centrifugal pump which draws the water from the bottom of the radiator and forces it upward to the cylinders, whence through vertical stand pipes it is carried clear to the bottom of the water jackets, thus insuring a thorough cooling of the cylinders. The hot water from the engine then passes to the radiator, where it is cooled and delivered back to the pump. A pressure gauge is placed on the dashboard; if the clutch be released temporarily, and the engine speeded up, the pressure gauge will register several pounds, thus indicating that everything in the circulating system is in a satisfactory condition. When no pressure is registered it is an indication that the gauge is out of order or that the water supply needs to be replenished.

the water passing around them. In operation, water is drawn in at one side of the chamber and forced out at the other side.

Ques. What happens if the discharge pipe become obstructed so as to stop the flow of water?

Ans. The pressure will increase, but owing to leakage between the revolving gears and their casing, it will not rise above thirty to forty pounds per square inch.

Ques. How does a centrifugal pump work?

Ans. In this pump a number of curved blades fixed to a hub are rotated in a closed chamber. The water, which enters the chamber at the center, is caught by the rapidly revolving blades, and thrown outward by centrifugal force against the casing, whence it passes off through the discharge outlet.

Ques. Describe a propeller pump?

Ans. In this type of pump the blades are so arranged that they not only throw the water out by centrifugal force, but act also as a kind of screw to push the water along from the inlet to the outlet of the pump.

A propeller pump of good design has the casing with the water inlet concentric with it. The water outlet is at one side of the pump chamber. A cover which fits on the flat face of the pump chamber carries a bearing in which is mounted the propeller shaft. On this is the propeller blade, which fits the inside surface of the pump chamber. The shape of the propeller blade is such that water entering at the inlet is forced along both forward and outward through the outlet, partly by centrifugal force and partly by the thrust of the propeller blades.

The advantages of a propeller or centrifugal pump are noiseless operation, and the fact that if anything becomes jammed and the pump stops, the circulation will continue by thermal action, thus to some extent preventing overheating from failure of the pump.

Ques. Where are the water connections located on the cylinder?

Ans. The inlet pipe is placed at the lowest point of the water jacket space, and the outlet on the opposite side at the highest point.

Ques. What advantage does this arrangement possess?

Ans. The cold water entering at the bottom cannot gravitate to a lower level; if it should enter at the top it would tend to displace the heated lower layers, thus eddy currents would be set up, and the cylinder would not be uniformly cooled.

Ques. How is the pump driven?

Ans. It is driven by the engine through gear wheels.

Ques. What provision is made to prevent injury in case the pump should freeze?

Ans. Usually some form of joint is interposed between the pump and engine, which will give way more easily than the pump.

Ques. What fitting should be provided on the pump?

Ans. A drain cock should be placed at the bottom of the pump casing so the water may be drawn off.

Ques. What is the construction of a "honeycomb" radiator?

Ans. This type consists of numerous short lengths of small tubing of square cross section, placed side by side and held together by solder at the ends, the structure presenting the appearance of a "honeycomb."

Ques. Explain the operation of a honeycomb radiator?

Ans. The heated water from the engine enters at the top and circulates to the bottom, flowing through the small spaces between the tubes. A strong current of air induced

by a fan, and also by the motion of the car, passes through the tubes and absorbs heat from the water.

Ques. What should be the velocity of water circulation in the cooling system?

Ans. The flow should be such that the temperature of the discharge into the radiator is within a few degrees of the boiling point.

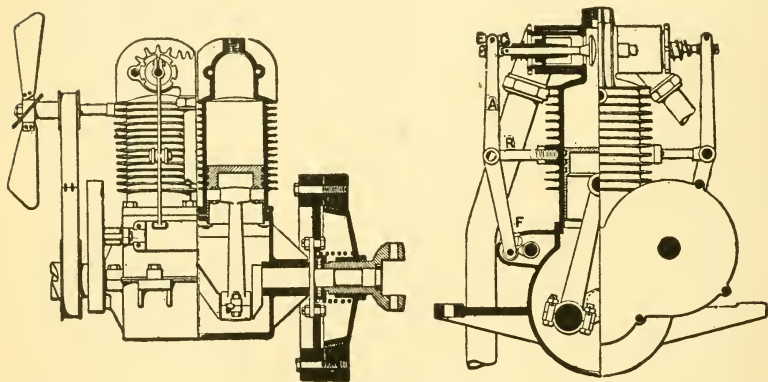

Fig. 17.—The Cameron air cooled engine. The fan shown at the left cools the cylinders by inducing a current of air, which passes over the large surface presented by the numerous ribs. The valves are located above the cylinder bore in opposite chambers and work horizontally. Each valve is operated by a long vertical lever *A*, pivoted at *R*. The upper end *E* bears upon the end of the valve stem, and its lower end carries a roller against which bears the camshaft cam. The upper end of the lever or valve rocker arm is split and takes a threaded piece at *E*, which rests upon the end of the valve stem. By the adjustment of this the timing of the valve is accomplished. The lower end, with its roller is contained within a small extension on a detachable plate secured to the side of the crank case, the end of the valve rocker arm working in a slot *F* in the top of the extension.

Ques. Why should the temperature be kept below the boiling point?

Ans. To prevent the supply being rapidly exhausted by evaporation.

Ques. How much cooling surface is required?

Ans. With gravity circulation, five square feet per horse power; in the case of mechanical circulation the amount necessary is somewhat less due to the more rapid flow of the water.

Answers Relating to the Air Cooling System

Ques. Explain the air cooling system.

Ans. In this method the cylinders are cooled by a strong current of air, induced by the movement of the car, and aided by a rapidly revolving fan.

In the Franklin method of air cooling, the absorption of heat from the engine is accomplished by inducing a flow of air down around the cylinders in such a manner that each cylinder receives as much cooling air as its neighbor, and all the air transferred comes into intimate contact with all the radiating surface of the several cylinders.

This flow of air is obtained by enclosing the engine in a sheet metal chamber, inside of which the air pressure is kept less than that of the atmosphere by the fly wheel suction fan, which tends to produce a vacuum in the chamber.

The current induced by the suction of the fan passes through small annular spaces around each cylinder, formed by sheet metal jackets surrounding the radiating fins. The air, in its coolest condition, enters these jackets from the top, and strikes the hottest part of the cylinders first; with this arrangement the distribution of the air is equalized.

Ques. Is air as efficient as water for absorbing heat from the cylinders?

Ans. No.

Ques. How is this deficiency overcome?

Ans. The radiating surface of the cylinder is considerably increased by numerous ribs or rings, also by inserted pins or tubes.

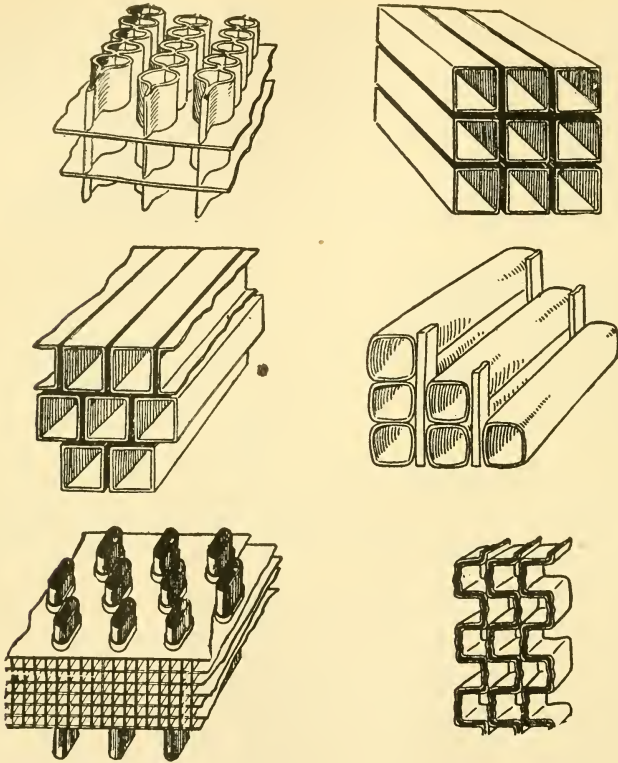

Figs. 18 to 23.—Types of radiator construction; fig. 18, Harrison tubular; fig. 19, Fedders staggered air tube; fig. 20, Fedders square air tube; fig. 21, A-Z vertical type; fig. 22, Buscoe vertical type, fig. 23, Livingston zig-zag tube. In the construction of radiators, copper, or its alloy, brass, is used on account of its great capacity for conducting heat, the weight then can be kept low. It also has mechanical advantages such as ease of forming and soldering.

Ques. Why is the water cooling system more efficient than the air cooling system?

Ans. Because a larger and better arranged radiating surface can be provided in a radiator than on a cylinder;

in either case the excess heat is carried off by the air. The water simply serves as a medium to conduct the heat from the engine to the radiator.

Ques. In the air cooling system, where is the fan located?

Ans. Usually under the bonnet in front of the engine.

Ques. Would its operation be as efficient, if placed aft of the engine and arranged to induce an air current by suction?

Ans. No, because air expands as its temperature rises, hence, for a given number of revolutions a greater volume of air is displaced when the fan is placed in front of the engine.

Ques. How is the fan driven?

Ans. By belt, chain or bevel gear drive, fastened either to the crank shaft or to the cam shaft.

Ques. What types of belt are used?

Ans. Leather and steel belts; the latter in the form of a closely coiled spiral spring.

Ques. What objections are there to a belt drive?

Ans. It is not a positive drive; there is more or less slip, especially if moisture and oil be present.

Ques. How much faster does the fan revolve than the crank shaft?

Ans. It is usually geared to make about two or two and one-half revolutions to one of the crank shaft.

Ques. How should the fan be made?

Ans. As light as possible, to reduce vibration and inertia.

The Makeup of Petroleum

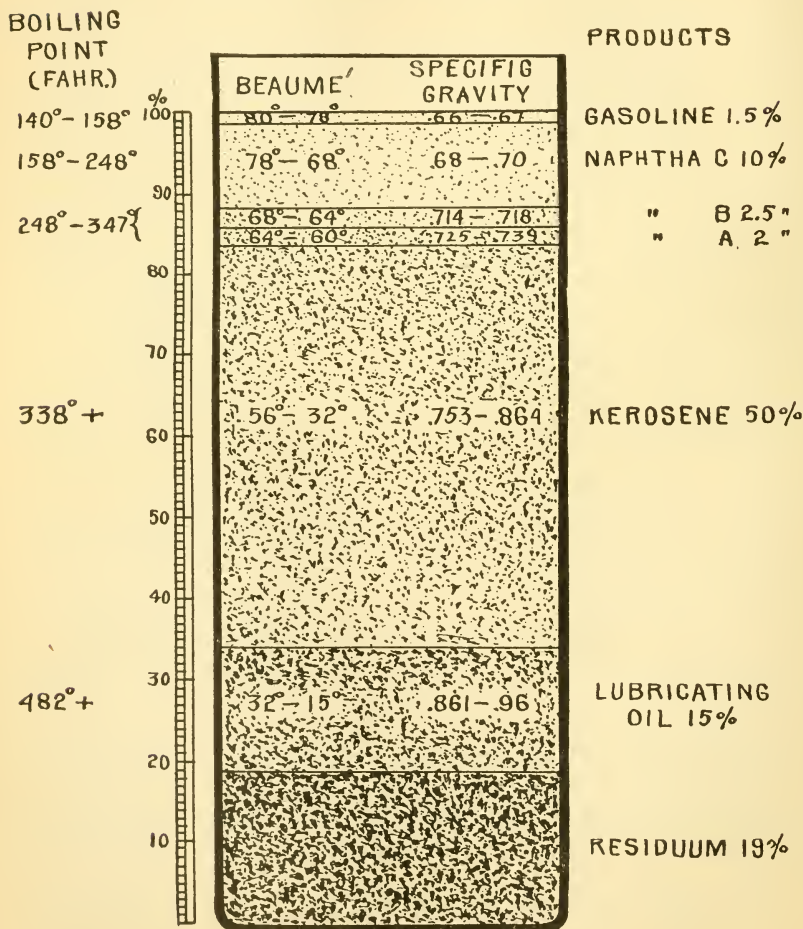

Fig. 24.—The various products obtained by the distillation of petroleum. In the process of distillation these products are separated according to their boiling points as indicated.

GASOLINE AND OTHER FUELS

It is important, not only for economy but for safety, that all should know something of the origin, production, and nature of the fuel used in the engine. Economy in the consumption of fuel in any kind of engine consists in using just enough for the purpose.

When the fuel is introduced into the combustion chamber with another element, as with air in the case of the internal combustion engine, a knowledge of the nature of the fuel will aid in determining the proper proportions for an economical mixture; it will also point out the manner of handling the fuel, so that it may be safely used without risk of fire or explosion.

Answers Relating to Gasoline and other Fuels

Ques. What is petroleum?

Ans. The word "petroleum" means **rock oil**. It is a liquid inflammable, bituminous substance exuding from the earth or collected on the surface of water in wells. Petroleum is composed essentially of carbon and hydrogen.

Crude petroleum, rock oil, mineral oil, or natural oil, as it is sometimes called, is a dark brown or greenish inflammable liquid

which, at certain points, exists in the upper strata of the earth, from whence it is pumped or forced by pressure of the gas attending it. It consists of a complex mixture of various hydrocarbons, and is refined by distillations. The chief products include gasoline, naphtha, benzine, kerosene, lubricating oil and paraffin.

Ques. How and where is petroleum found?

Ans. It is obtained by boring to the rock-bearing strata, and is found in the United States, Canada, at Baku on the Caspian Sea, in Burma, Roumania, and other places.

Ques. What is crude oil?

Ans. Petroleum in its natural state, as it flows or is pumped from the ground.

Ques. What is gasoline?

Ans. Gasoline is an arbitrary name first given to certain gravities of naphtha used for making illuminating gas in isolated plants; it is a colorless, inflammable fluid, one of the first distillants of crude petroleum.

Except for two hydrocarbons, which are gaseous at ordinary temperatures, gasoline is the most volatile of the products of crude petroleum, and consequently, is the first to come off in the process of distillation.

Few really know the mysteries of gasoline. Most drivers look upon the fluid as something which provides the power that drives the engine. Even the better informed sometimes fail to qualify as experts when it comes to answering the question: What is gasoline?

Ques. How is gasoline obtained from crude oil?

Ans. The crude oil is placed in a closed vessel and heated, the most volatile and lighter parts evaporate first; the resulting vapor is passed through a condenser where it is cooled and condensed; gasoline is the first distillation before kerosene.

Ques. What is distillation?

Ans. Distillation is an operation by which a volatile liquid may be separated from a substance which it holds in solution or by which liquids of different boiling points may be separated. The operation depends upon the transformation of liquids into vapor by the action of heat, and on the condensation of this vapor by cooling.

Ques. How are the different oils separated?

Ans. Crude oil is distilled in fractions, which are separated according to their boiling points. The most volatile part boils at from 113° to 138° Fahr., this is known as petroleum ether; the next product boiling from 140° to 158° is termed gasoline; benzine comes over from 160° to 200° , and is followed by various naphthas, evaporating at points ranging from 200° to 300° .

The foregoing are all combined to make American commercial gasoline, various fractional distillates being taken at intermediate points for such substances as benzoline, naphtha, etc. Kerosene is evaporated over a temperature range from 300° to 500° , the extent depending upon the quality of oil demanded; this is followed by gas oil or solar oil used for gas enrichment.

Ques. What is left after the distillation of gasoline and kerosene?

Ans. If the distillation process be continued, the heavier oils are vaporized and condensed. This comprises nearly half the bulk of the crude oil. Finally come the heavier lubricating oils and paraffin wax used for making candles.

Ques. Describe the practical method of distillation of petroleum

Ans. The stills or retorts may be of any shape or size. They may be cylinders placed horizontally, and in banks, or standing perpendicular and having curved domes.

Rectification, that is, the separation of the fractional distillates, is effected by a copper coil many feet in length, inside the retort and passing through the crude petroleum, carrying steam at a high pressure, assisted by a gentle fire.

Each retort has an inlet pipe for the crude petroleum and an outlet pipe for the distillant. The outlet pipe passes over the side and down to a cooling coil or worm immersed in cold running water. This worm acts as a condenser, that is, it changes back to liquid form the vapors driven off the petroleum by the heat. A smaller pipe leads from the condenser to the receiver, having glass sides, through which the still man can watch the flow of the distilled oil.

From the bottom of the receiver a number of pipes lead to different storage tanks, each pipe having a cut-off valve to regulate the flow of the varying gravities to their proper tanks.

The first product from the retort is a gas formed by the mingling of the fumes of the petroleum with a small volume of air left in the reservoir. This is sometimes conveyed to the fire box and used as fuel. When the first flow of the distillant reaches the receiver, the still man tests it with a Beaumé hydrometer for its density. Usually this first flow is found to be about 90. It is of a highly volatile nature, so nearly a gas that when exposed to air it rises

in an invisible vapor and quickly evaporates. It cannot be confined for any length of time in barrels, even if they have been successively coated inside with wax and repeatedly painted on the outside to make them air tight. Even in the coldest weather it will pass through the wood. For these reasons this gravity is not put out commercially, but is used to bring up the gravity of a mass made of heavier fractions; that is to say, if 88 Beaumé gasoline is being tanked the still man lets all the 90, 89, 88 and enough of the 87 oil flow into the receiver to make an average mixture.

The oil is repeatedly tested with the hydrometer until the right gravity has been produced in the receiver, when it is let off to the proper storage tank. In the same way, if 82 is the next grade wanted, all the gravities from 86 down to perhaps 78 are commingled in the receiver until a uniform fluid of the required gravity is obtained to let off into its tank. This process is called fractioning, and is continued through gasoline into kerosene, the next distillant, down to about 32 degrees.

As the market for gasoline, such as is used in automobiles and gasoline engines in general, is perhaps as great if not greater than all the other products of crude petroleum, it has been necessary for the oil manufacturers to convert as great a portion of it into a suitable grade of gasoline as possible. The ordinary grade of gasoline, therefore, tests about 62 or 64 degrees Beaumé at a temperature of 60 degrees Fahrenheit.

It must be remembered that with every fall of 10 degrees in the temperature of gasoline, there will be a drop of 1 degree on the Beaumé scale. Thus it will be seen that the gasoline now in general use and testing around 62 degrees Beaumé is in reality a blend of the highest grade of gasoline, the naphthas, C, B and A and much of the kerosene.

Ques. What is petrol?

Ans. The term "petrol" is generally applied to automobile fuel in England and upon the Continent. Petrol, originally, was a moderately heavy benzine, the first available fuel put on the French market, but the term has been extended to cover all light petroleum products, much in

the same way as the American usage of the term gasoline has widened to include all the light volatile hydrocarbons known to refiners the world over as benzine.

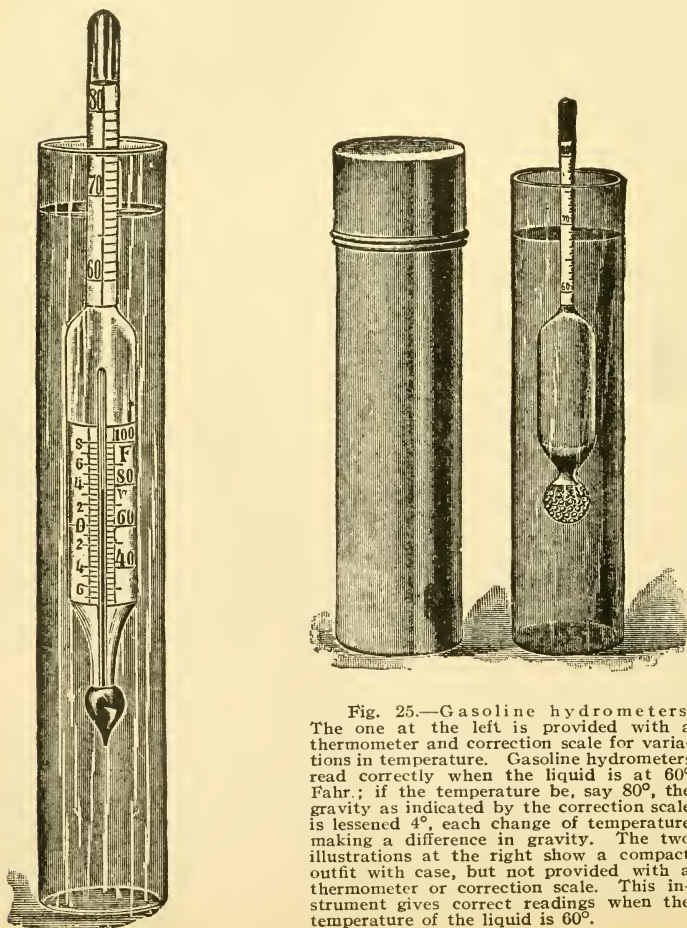

Fig. 25.—Gasoline hydrometers. The one at the left is provided with a thermometer and correction scale for variations in temperature. Gasoline hydrometers read correctly when the liquid is at 60° Fahr.; if the temperature be, say 80°, the gravity as indicated by the correction scale is lessened 4°, each change of temperature making a difference in gravity. The two illustrations at the right show a compact outfit with ease, but not provided with a thermometer or correction scale. This instrument gives correct readings when the temperature of the liquid is 60°.

Answers Relating to Hydrometers

Ques. In what other way, besides the temperature test can the products of crude oil be distinguished?

Ans. By their weight relative to an equal bulk of water, that is, by their **specific gravity**.

Ques. How is the specific gravity determined?

Ans. By a hydrometer.

Ques. Describe a hydrometer.

Ans. The ordinary type is a short tube of glass with a stem similar to that of a thermometer, and having a small receptacle at the bottom in which lead shot are placed to cause the instrument to stand vertical and sink into the liquid until well covered. The depth to which it sinks depends upon the density of the fluid, that is, the lighter the fluid the deeper will the instrument sink. The stem is provided with an arbitrary scale, the divisions of which are called degrees. For testing gasoline, the Beaumé scale is used, in which zero corresponds to a solution of salt of specific proportions, and ten degrees corresponds to the density of distilled water at a specific temperature, or to a specific gravity of unity. The rest of the stem is divided into divisions of equal size up to ninety degrees.

Ques. How is the instrument modified to tests of various grades of gasoline?

Ans. To avoid long stems, hydrometers are made to cover only a small range of degrees. For testing the various grades of gasoline, the scale usually extends from 60 to 80 degrees.

Ques. How do temperature variations affect the hydrometer?

Ans. A change of temperature will change the float point and introduce an error in the reading.

It is not generally known how great a difference in specific gravity is caused by variations in temperature. All gasoline hydrometers are assumed to be used at a temperature of 60° Fahr., but, if for instance, the temperature be 80° , the gravity is lessened 4° , each change in temperature making a difference in specific gravity.

Ques. What provision is made in approved hydrometers for temperature changes?

Ans. They contain a thermometer having a correction scale as shown in fig. 25, which indicates the number of degrees that must be added or subtracted from the reading of the hydrometer to obtain the true value.

Answers Relating to Gasoline

Ques. What is considered the proper test of gasoline for the automobile engine?

Ans. About 70° to 76° ; the latter represents the better quality.

Ques. Can fuel of these grades always be obtained?

Ans. No; in most cases the automobilist has to take what he can get.

Ques. What is the nature of gasoline?

Ans. Gasoline is a liquid which has a very low boiling point, and which constantly evaporates even at ordinary temperatures. The vapor is heavier than air, hence, if the liquid vaporize in a closed room the vapor sinks to the floor.

Ques. How can a room be cleared of gasoline vapor?

Ans. By thorough ventilation; the vapor being heavier than air, should be allowed to escape through openings

near the floor; the movement of the vapor should be assisted by induced draft with a fan or by similar means.

Ques. Where is there great danger of fire in a garage?

Ans. At or near the floor.

Ques. What is "stale" gasoline?

Ans. Gasoline whose density has reached a point due to exposure to the atmosphere such that it does not evaporate freely.

It follows, therefore, that unless stored in an air tight vessel, the lighter constituents of the liquid will escape, leaving a residue that will show a registry on the Beaumé scale too low for successful use in a carburetter. This process will occur in a carburetter, if the gasoline be allowed to stand in it for any length of time. It is always best, therefore, after standing for a protracted period, to drain the carburetter if any difficulty be experienced in starting. Of course, if the tank be found to contain only low degree liquid, the only alternative is to empty it and refill with a new supply of the proper gravity.

Ques. What use can be made of stale gasoline?

Ans. It may be used for removing grease and dirt from the engine or other metal parts of the car. It has, however, a disagreeable odor.

Ques. How should gasoline be handled?

Ans. It is important to keep it away from the air, and also from a flame. Ignition of the liquid results in a fire; ignition of the vapor mixed with air results in an explosion.

Ques. How should a gasoline fire be extinguished?

Ans. Sand or some dry chemical extinguisher should be used. A moistened blanket or lap robe is also effectual; a stream of water should not be used.

Ques. How should gasoline be stored?

Ans. In an underground tank. The tank may be buried at any convenient spot near the garage and piped to the building, and a pump installed. The more expensive outfits are equipped with pump and automatic measuring devices. In some cases a flow of gasoline is obtained by gravity or by air pressure.

Answers Relating to Kerosene

Ques. How is kerosene used as a fuel?

Ans. The method of fuel supply usually employed consists in spraying the oil, by means of an atomizer, into a hot chamber in which the spray is readily vaporized and mixed with heated air to form the charge for the engine. Some engines are provided with a reservoir located at a given height above the cylinders, from which the oil is fed in liquid form into the air admission chamber at the valve opening into the cylinder.

Ques. What difficulty is encountered in the use of kerosene?

Ans. The process of vaporization requires the raising of the temperature of the oil vapor and the air with which it is mixed to a temperature ranging from 250° to 300° Fahr., at atmospheric pressure. As a result, the specific gravity of the charge is greatly reduced, so that a given volume contains a lesser number of thermal units than when it is introduced at atmospheric temperature; furthermore, the consequent higher initial temperature results in a higher compression temperature for a given pressure than that attained with gasoline. The total result is a higher tem-

perature throughout the cycle and a greater loss of heat through the cylinder walls than is the case when the charge is admitted to the cylinder at atmospheric pressure.

Ques. What is the advantage of kerosene as a fuel?

Ans. Its cheapness.

Ques. What are the disadvantages?

Ans. The difficulties attending its use; its lower heating value, and the fact that it is not so "clean" a fuel as gasoline.

Ques. What other fuel has been used for gas engines?

Ans. Alcohol.

Answers Relating to Alcohol

Ques. What is alcohol?

Ans. There are some twenty-four compound substances known to the chemist as alcohol, of which the two most important are **ethyl**, or ordinary alcohol, and **methyl** or wood alcohol.

Ques. How is alcohol obtained?

Ans. It is obtained from any substance naturally containing sugar, as grapes, fruits, beet roots, molasses, etc., by **fermentation**; other substances require first to be transformed into sugar before fermentation can take place.

Methyl alcohol is obtained from the dry distillation of wood in closed retorts, giving a watery product known as **pyroligneous acid**. This is repeatedly distilled, in conjunction with various re-agents for the purpose of removing impurities and the contained water, the crude resultant alcohol being known as **wood spirit**.

Ques. What is denatured alcohol?

Ans. Alcohol that has been rendered unfit for use as a beverage by the addition of a portion of wood spirit, which is a poison, and also, to prevent the chemist redistilling the ethyl alcohol, a proportion of one-half of one per cent of benzine or other hydrocarbon is added.

Ques. Why is alcohol denatured when used as a fuel?

Ans. In order to obtain it at a lower price by avoiding the heavy tax imposed on alcohol for use as a beverage.

In 1906, the Congress of the United States removed the tax on denatured alcohol, in order to grant American manufacturers equal opportunities with those enjoyed by their competitors in other countries.

Ques. What are the necessary conditions for using alcohol as a fuel?

Ans. For complete vaporization heat is necessary; on this account the carburetter is frequently heated by the exhaust or by water jacketing. A higher compression than is commonly used with gasoline is necessary, in order to obtain as high a power efficiency as possible. Reliable sparking devices are also essential, in order to produce complete combustion.

Ques. How do alcohol and gasoline carburetters compare in operation?

Ans. A carburetter designed for alcohol may be used with gasoline, but the reverse conditions are not true. The time required for the evaporation and combustion of alcohol is greater than that required for gasoline, but a higher mean effective pressure is realized. Moreover, when alcohol is used as a fuel the noise of operation is reduced.

Ques. What is the fuel consumption with alcohol?

Ans. It has been given as slightly over one pint per horse power per hour according to purity.

An interesting test of power efficiency has been made with a motor vehicle used for dragging a plow. With two gallons of gasoline three roods were plowed; with two gallons of kerosene three roods, thirty-five poles; with two gallons of alcohol, two roods, twenty-five poles.

The following conclusions regarding the use of alcohol as fuel for engines as compared with gasoline are based on the results of careful experiments:

1. Any engine operating with gasoline or kerosene can, with proper manipulation, operate with alcohol fuel without any structural change whatever.

2. It requires no more skill to operate an alcohol engine than one intended for gasoline or kerosene.

3. There seems to be no tendency for the interior of an alcohol engine to become sooty, as is the case with gasoline and kerosene.

4. Alcohol contains approximately 0.6 of the heating value of gasoline, by weight; a small engine requires 1.8 times as much alcohol as gasoline per horse power hour. This corresponds very closely with the relative heating value of the fuels indicating practically the same thermal efficiency of the two when vaporization is complete.

5. In some cases, carburetters designed for gasoline do not vaporize all the alcohol supplied, and in such cases the excess consumed is greater than that indicated above.

6. The absolute excess of alcohol consumed over gasoline or kerosene will be reduced by such changes as will increase the thermal efficiency of the engine.

7. The thermal efficiency of these engines can be improved when they are to be operated by alcohol, first by altering the construction of the carburetter to accomplish complete vaporization, and second, by materially increasing the compression.

8. An engine designed for gasoline or kerosene can, without any material alterations to adapt it to alcohol, give slightly more power (about 10 per cent.) than when operated with gasoline or kerosene, but this increase is at the expense of greater consumption of fuel. By alterations designed to adapt the engine to the new fuel this excess of power may be increased to about 20 per cent.

9. The different designs of gasoline or kerosene engines are not equally well adapted to the burning of alcohol, though all may burn it with a fair degree of success.

10. Storage of alcohol and its use in engines is much less dangerous than that of gasoline, as well as being decidedly more pleasant.

11. The exhaust from an alcohol engine is less likely to be offensive than the exhaust from a gasoline or kerosene engine, although there will be some odor, due to lubricating oil and imperfect combustion if the engine be not skillfully operated.

12. With proper manipulation, there seems to be no undue corrosion of the interior due to the use of alcohol.

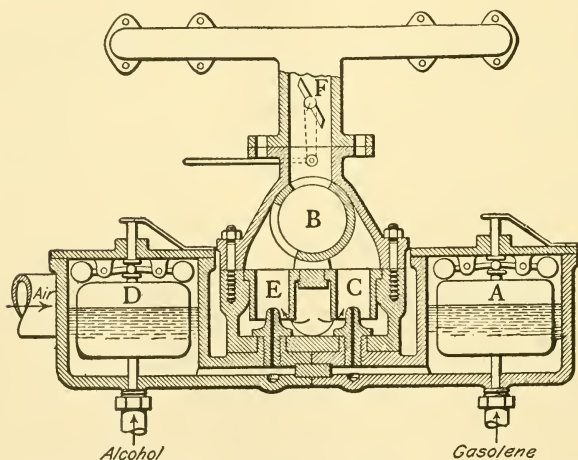

Fig. 26.—A double float feed carburettor for alcohol and gasoline. A, float in gasoline chamber; B, rotary valve controlling outlet of alcohol or gasoline mixture to engine space, through nozzles C or E; D, float in alcohol chamber; F, butterfly valve for controlling volume of fuel charge.

13. The fact that the exhaust from the alcohol engine is not as hot as when gasoline or kerosene is used, seems to indicate less possibility of burning the lubricating oil. This is borne out by the fact that the exhaust shows less smoke.

14. In localities where there is a supply of cheap raw material for the manufacture of denatured alcohol, and which are at the same time remote from the source of supply of gasoline, alcohol may immediately compete with gasoline as a fuel for engines.

15. There is no reason to suppose that the cost of repairs and lubrication will be any greater for an alcohol engine than for one built for gasoline or kerosene.

CARBURETTERS

The term carburetter is applied to any device wherein gasoline vapor and air are mixed in proper proportions to form the fuel charge for an internal combustion engine.*

There is a distinction between the words carburetter and vaporizer.

The word "carburetter" is applied when, in addition to a mixing chamber, the device contains a receiving chamber for the gasoline and means of maintaining therein a constant level of the fuel.

The word "vaporizer" is applied when the device has no receiving chamber; as a "generator valve."

Answers Relating to Carburetters

Ques. What are the duties of a carburetter?

Ans. It should so control the supply of air and gasoline that the resulting mixture will always contain the two ingredients in the proper proportions. There must not be too much gasoline vapor, as fuel would be wasted either by being decomposed into soot or unburned on account of insufficient supply of air to consume it. Again, too

*NOTE.—The fuel charge for a gas engine consists of about ten to sixteen parts air to one of gasoline vapor. The proportion varies according to the conditions of the atmosphere, quality of gasoline and engine speed.

much air, though the mixture should ignite, would lower the temperature of combustion and thus diminish the expansion.

Ques. Name two important types of carburetters.

Ans. The "sprayer," and the "surface," carburetter.

Ques. How do these differ in operation?

Ans. In the sprayer carburetter, the fuel is atomized through a minute nozzle and mixed with a passing column or current of air. The action of a surface carburetter consists in passing air over the surface of a small "puddle" of the fuel.

Ques. Which is the prevailing type?

Ans. The sprayer.

In explaining the principles of carburetter operation, owing to certain characteristic differences in behavior it will be best to treat the sprayer and the surface types separately.

Ques. Describe a rudimentary sprayer carburetter, such as will serve to illustrate carburetter principles.

Ans. For this purpose, the essential features necessary to produce a proper fuel mixture are shown in fig. 27. The drawing illustrates a receiving chamber A and a mixing chamber B, the two being connected by a small passage-way or duct which terminates at the sprayer C, made adjustable by the needle valve D. The lower end of the mixing chamber B is open to the atmosphere, while the upper end is provided with auxiliary air ports F, having a collar or sleeve G with which to adjust the opening of the ports to the atmosphere.

Ques. In explaining the action of this rudimentary carburetter, what is assumed with respect to the receiving chamber A?

Ans. It is assumed that the receiving chamber A is filled with gasoline to a level MN, very near the elevation

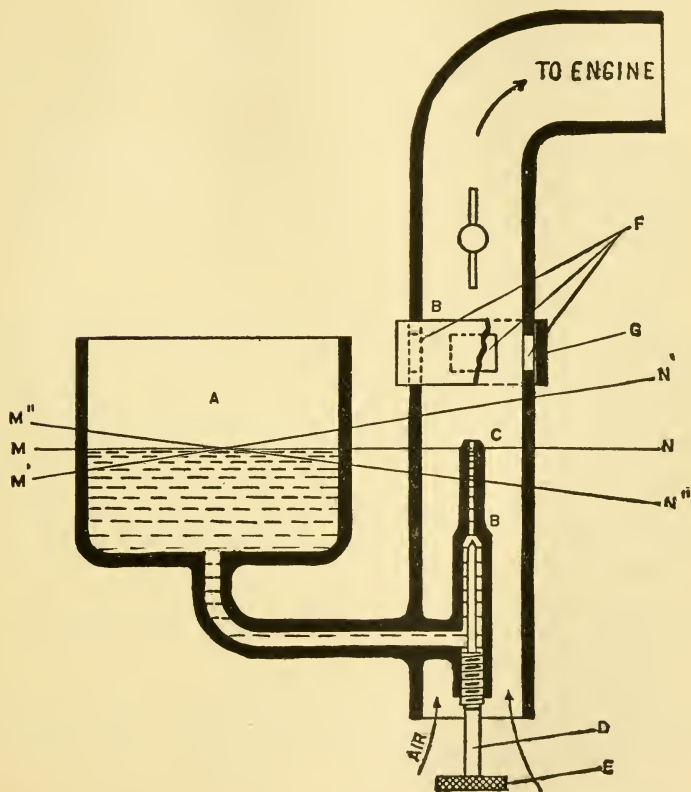

Fig. 27.—A rudimentary, or simple form of spray carburettor illustrating the principles of operation employed in the modern device. A, is the receiving chamber; B, the mixing chamber. A connecting passage conveys fuel to the spray nozzle C, controlled by the needle valve D, by turning the thumb wheel E. Air enters through the primary passage in the base and through the auxiliary ports F, the latter being adjustable by the sleeve G, and the mixture to the engine, controlled by a throttle located above the sleeve.

of the spray nozzle, and that the supply is replenished as it is used so that the fluid level MN is kept constant.

Ques. Where is the carburetter connected to the engine?

Ans. At the upper end of the mixing chamber, beyond the throttle, as shown in fig. 27.

Ques. Describe the effect of the suction strokes of the engine?

Ans. Each suction stroke displaces a volume of air, causing a partial vacuum in the mixing chamber B; the intensity of the vacuum, as will be seen, depends on the speed.

Ques. Describe the fuel adjustment.

Ans. Assuming the engine to be working at slow speed with a heavy load, and the auxiliary ports F closed by the sleeve G, the gasoline supply may be adjusted by the needle valve E so that the engine will receive from the carburetter a mixture containing the proper proportion of gasoline vapor and air.

Ques. What name is given to the air supply entering at the bottom of the carburetter?

Ans. The primary air.

Ques. What name is given to the air supply entering through the auxiliary ports?

Ans. The secondary air.

Ques. If part of the load on the engine be removed so that it will run, say, twice as fast, will the same amount of air and gasoline be delivered for each charge?

Ans. Under these conditions, the mixture will become too rich, that is, too much gasoline will be fed for the amount of air passing through the inlet at the lower end of the mixing chamber.

Ques. Why is this?

Ans. The excess of gasoline is due to the fact that, in order to get twice the amount of air through the inlet,

the suction has to be more than doubled to compensate for the increased frictional resistance set up by the higher velocity of the air passing through the inlet. The suction, or degree of vacuum in the carburetter, being more than doubled, will induce a flow of more than twice the amount of gasoline.

Ques. What causes the velocity of the air to increase in passing through the inlet?

Ans. This is due to the expansion of the air, in entering the carburetter; resulting in an increase of velocity more than two-fold after expansion.

Ques. How may the suction be restored to its normal condition so that the mixture will not become too rich?

Ans. By slightly raising the sleeve G so as to partially open the auxiliary air ports F. This allows some air to enter through the auxiliary air ports, thus reducing the velocity of the entering air and relieving somewhat the suction at the lower inlet. The amount of opening of the auxiliary air ports F, necessary for any change of engine speed is found by experiment.

Ques. How may the engine speed be maintained constant under varying load?

Ans. If a throttle valve be placed in the passage B between the auxiliary ports and the engine, the load may be altered without any variation in the engine speed, by adjusting the throttle opening.

Ques. How does the modern carburetter differ from the rudimentary or primitive device shown in fig. 27?

Ans. In actual construction, automatic devices are employed to maintain the gasoline in the receiving chamber at constant level and to adjust the auxiliary port openings to different engine speeds.

Ques. What name is given to the receiving chamber?

Ans. The term **float chamber** is used instead of receiving chamber, since a float is almost always used to regulate the flow of gasoline into the chamber.

Ques. What is the first requirement of a modern carburetter?

Ans. An automatic device, such as a float, to maintain the gasoline supply in the float chamber at practically the same elevation as that of the spray nozzle.

Ques. Why is this necessary?

Ans. An initial suction is required to lift the gasoline to the mouth of the nozzle before spraying can begin. The slightest suction only is required to draw air through the primary air inlet, there is, however, a certain minimum suction below which no gasoline can be fed, depending on the difference in the level of the supply and the level of the spray nozzle. It is therefore important to eliminate this difference in level.

Ques. Describe the float feed method of maintaining the fuel supply at a constant level.

Ans. A "float feed" device consists of a cork or hollow metal float placed in the float chamber. It is connected so as to operate the gasoline inlet valve, usually by means of levers. These are arranged in such a manner that, as gasoline enters the float chamber through the inlet valve, the float rises, and in so doing, closes the valve, thus shutting off the supply when the gasoline reaches the desired level.

Ques. What other method is sometimes used?

Ans. In a few instances, some form of overflow arrangement is provided whereby gasoline is maintained at the

necessary level by a surplus volume being pumped or otherwise forced into a chamber whence the overflow returns to the main supply, the height and capacity for the return of the overflow maintaining the necessary level with reference to the spray nozzle.

Ques. Describe the disc feed.

Ans. In this method of controlling the supply of fuel, the air is drawn through a passageway containing a minute

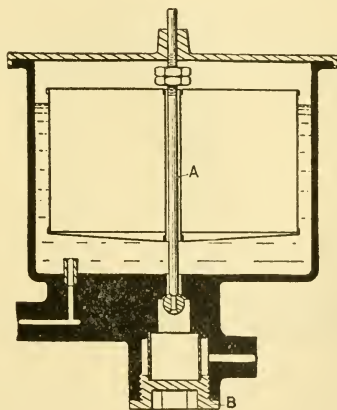

Fig. 28.—Simple form of float feed, with float concentric to inlet valve. There is a strainer at the inlet, accessible for cleaning by removing the plug.

fuel opening. This opening is closed by a needle valve which has a disc of very thin sheet metal attached to the stem. When no air is passing through the carburettor, the needle valve closes the gasoline nozzle. As soon as air is drawn through, the current striking against the disc, lifts it from its seat. Gravity and suction then both bring gasoline out of the nozzle to mix with the air. The lift

of the valve and its disc are controlled by an adjustable screw which regulates the extent of the movement.

Ques. Explain the diaphragm feed.

Ans. This mode of regulating the gasoline supply depends on the action of reduced air pressure on a diaphragm supported at its circumference, and free to move at the center. The needle valve for controlling the sup-

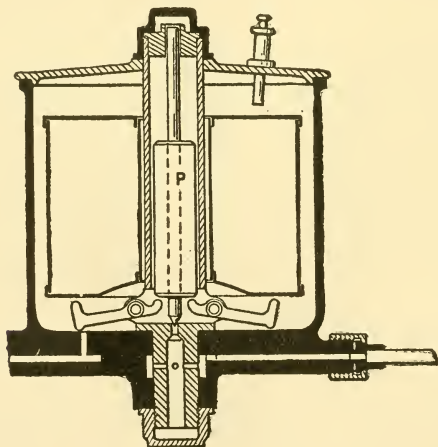

Fig. 29—Type of float feed in which the fuel supply is made adjustable by the use of a variable counterweight P.

ply of gasoline is held on its seat when no air is passing. As soon as air is drawn through the carburetter the pressure is reduced on one side of the diaphragm; this causes its center to move. The needle valve being attached to the center of the diaphragm, is lifted from its seat, which allows gasoline to flow by gravity or suction, or both. Sometimes a piston is used instead of a diaphragm.

Ques. What is the usual level of the gasoline in the nozzle with respect to the nozzle top?

Ans. It varies in different makes of carburetters from about one-eighth to one-quarter inch below the top of the spray nozzle; to be accurate, the level should be such that the liquid will form a bubble at the nozzle to be blown off at will, and the exact height should be found by this method when the construction will permit.

Ques. When does this difference in level sometimes cause trouble?

Ans. In starting the engine. On account of the slow speed when cranking, the suction is very weak, sometimes it is not sufficient to raise the fuel to the top of the nozzle, or to give a proper mixture. In such cases, it is necessary to throttle the primary air supply to increase the suction.

Answers Relating to Float Feed

Ques. Describe a simple float feed?

Ans. A simple construction is shown in fig. 28. The float is constructed concentric with the inlet valve A, that is, it is placed around the same center. In the bottom of the float chamber is a small tube through which the gasoline must flow to the spray nozzle. The object of this tube is to prevent small particles of dirt and bubbles of water that may be in the gasoline entering the spray nozzle. The plug B at the bottom of the float chamber, has a wire screen to catch any foreign matter that may be in the gasoline, in order that it may not lodge in the spray nozzle and impede the flow of the liquid.

Ques. What is an important point in float feed construction?

Ans. There should be means of adjusting the height of the float to suit different grades of gasoline, as the level of the float depends upon the specific gravity of the liquid.

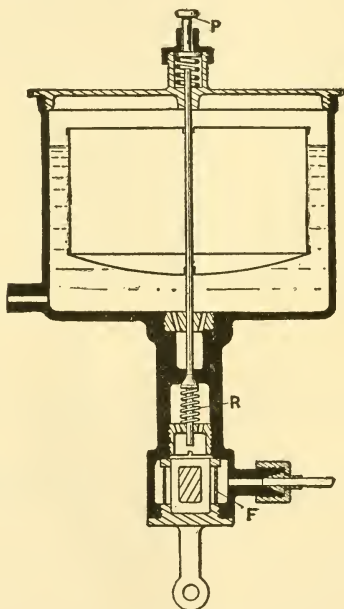

Fig. 30.—A form of float feed in which provision is made for adjusting the fuel level by means of a spring nut R. At F, is a wire gauze strainer to prevent foreign matter obstructing the nozzle. A plug is provided at the lower end, giving access to the strainer for cleaning.

Ques. What method is sometimes used for adjusting the float level or "float point," as it is called?

Ans. Counterweights are employed as shown in fig. 29; this construction is desirable owing to the facility with which the fuel level can be adjusted. To this end the counterweight P is either increased or diminished.

Ques. Is there any objection to this method?

Ans. Some authorities consider it bad practice to balance floats by weights in addition to the column of liquid in the float chamber, for, owing to their different densities, the liquid and the weights may interfere in their duties and destroy the perfect balance sought.

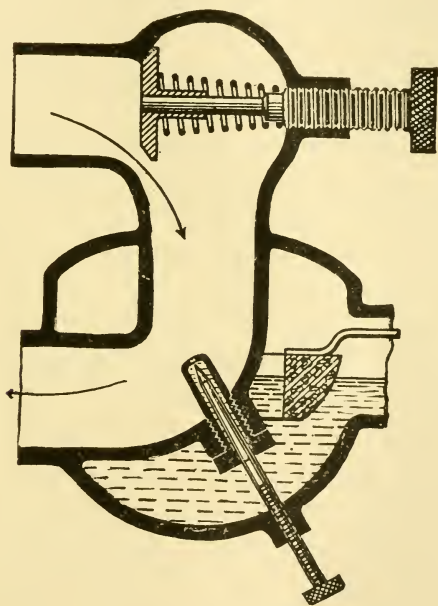

Fig. 31.—Type of carburetter having the float arranged concentric with the spray nozzle. This construction eliminates the disturbance of the fuel level with respect to the nozzle which otherwise would be caused by any inclination of the car.

Ques. How should the float chamber be placed with respect to the nozzle?

Ans. In order to obtain uniform results, especially where a car is operated on hilly roads, the float chamber

with its float should be constructed concentric with the spray nozzle as shown in fig. 31, so that any inclination of the car, in ascending or descending a hill, will not disturb the gasoline level with reference to the nozzle.

Ques. Explain the action of an "offset" float chamber?

Ans. In fig. 27, the line MN represents the normal height of the gasoline when the carburetter is level. Now, if the carburetter be inclined so that the line M' N' or M'' N'' becomes horizontal, these lines will then represent respectively the level of the gasoline, with reference to the spray nozzle, for the two inclined positions of the carburetter. Hence, it is evident that the gasoline level would be either too high or too low with respect to the nozzle, while remaining undisturbed at the float center.

Ques. Of what materials are floats made?

Ans. Usually cork or sheet metal.

Ques. What difficulty is sometimes experienced with cork floats?

Ans. They are liable to become saturated with gasoline, thus losing their buoyancy.

Ques. What objection is there to metal floats?

Ans. They sometimes leak.

Ques. How should they be constructed to avoid leaks?

Ans. The float should be without working joints, and particularly without frictional contacts with levers.

Ques. How should the float chamber be constructed?

Ans. It is advisable that the float chamber open at the bottom. This facilitates removal of any water, ice, or dirt, and removal of the float itself, without opening the top and permitting dirt to fall in from above. The float and removable bottom can be replaced with a stream

of gasoline flowing upon them, which will wash away particles of dirt, if any accidentally get on the parts while being replaced.

Ques. What difficulty is sometimes experienced with a top opening?

Ans. In this arrangement, ice in the bottom of the chamber may not only support the float and prevent it acting to admit gasoline, but may also bind the float so firmly that it cannot be removed to permit removal of ice, which may prove an unpleasant predicament if away from means of warming the carburetter.

Ques. How should the fuel flow through the float chamber?

Ans. It should enter from a single direction, either up or down, so that no pockets exist in which water or dirt may gather.

Ques. How may the inlet valve be kept tight?

Ans. The inlet needle valve may be kept tight and in perfect working order by occasional grinding. To facilitate this, the construction of the carburetter should be such that the valve is easily accessible.

Ques. What feature tends to keep the inlet valve in good condition?

Ans. The motion of the car tends to move the valve to some degree, even though slight, which movement serves to force away any particles of dirt that may lodge on the point during the passage of the liquid. On this account, it is best if the float and valve be fixed one to the other, so that the point partakes of the motion of the float and liquid in the chamber.

Ques. What feature is necessary for the proper operation of the float feed?

Ans. The float chamber must be provided with an air

vent to prevent the accumulation of any excess pressure which would interfere with the proper flow of the gasoline.

Ques. What is a float pin or "tickler?"

Ans. A device for depressing the float to obtain an excess of gasoline when such is required for starting the engine.

Ques. How may a rich mixture be obtained in starting without tickling the carburetter?

Ans. By throttling the primary air supply.

Some motorists regard it as a necessary preliminary in starting, to "tickle the carburetter," but carburetters differ; with some it is necessary that the level in the float feed chamber be high, in others not so high. Some carburetters flood easily, while others never flood.

It is as difficult to start on an over rich mixture as it is with a lean one. Any small tickling of the carburetter serves to start the nozzle and create a small amount of mixture. But this process soon floods the carburetter, and as the quantity of air supplied is small and cannot be increased to any great extent before the motor starts, flooding is apt to fill the inlet manifold with almost pure gasoline vapor and the motor will not start.

Many motors will start without touching the carburetter, and in the case of others the process of starting is rendered far easier by the moderate application of attention of this sort.

Ques. How should a carburetter be primed?

Ans. In priming a carburetter the float pin should be depressed and held down for a few seconds. This will cause as much, if not more, gasoline to enter in a given space of time than if the pin be worked like a pump. The latter operation as frequently performed is liable to injure the float.

Ques. Where is the float pin located?

Ans. It is usually arranged to pass down to the float through the air vent tube.

Ques. Why should the passage to the nozzle be both short and large?

Ans. Since gasoline has considerable weight, and consequent inertia, if the passage be short, the liquid will

respond more readily to the suction; if large, the friction will be less on account of the reduced velocity of flow.

With a long passage, the effect of inertia is more marked, causing the liquid to respond less quickly to the suction, the strength of which changes during each intake stroke. On account also of this inertia effect, the liquid does not get started until a considerable volume of air has passed the nozzle, making the early part of the charge too lean. Now, as the suction decreases, the inertia of the liquid causes it to continue to flow, making the latter portion of the charge too rich, and probably leaving between charges unsprayed drops of liquid, which either fall on the walls of the carburetter or are drawn into the engine.

Answers Relating to the Spray Nozzle

Ques. Name two types of spray nozzle?

Ans. The simple nozzle, fig. 32, and the multi-slot nozzle, fig. 33 or 34.

Ques. How do these compare?

Ans. The spraying effect in the simple form is less marked than that obtained with nozzles having a number of slots. However, with the single nozzle, there is less danger of it becoming clogged. The operation of a multi-slot nozzle is undoubtedly better than one with a single opening, but it is necessary for the construction to be such that it may be readily withdrawn to clean the small spray slots.

Ques. How is the supply of fuel through the nozzle regulated?

Ans. The amount of liquid passing through the nozzle may be varied by an adjustable needle or metal rod having a conical point.

Ques. How may the spraying qualities of a simple nozzle be improved?

Ans. By fitting it with a conical pointed needle valve working from above.

Ques. What connections should be made with the fuel valve?

Ans. The needle valve, which regulates the supply of fuel at the nozzle, should have suitable connections so that it may be adjusted by the operator, and enable him, while operating the car, to vary the proportion of the mixture,

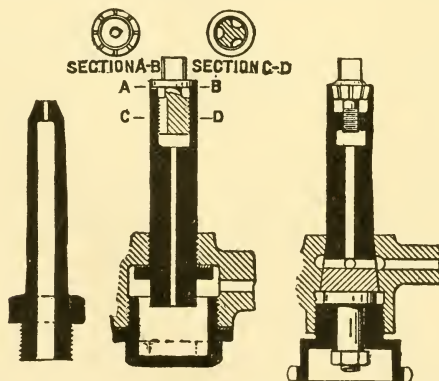

Figs. 32 to 34.—Some different forms of spray nozzles: fig. 32, a simple form with single opening; fig. 33, a nozzle consisting of a series of slots; fig. 34, multi-slot nozzle easily removable without the use of tools.

and thus secure the greatest power by trial, as well as to accommodate the device to the temperature and humidity of different days, and also to the gravity of different grades of fuel.

Ques. What is the object of multiple nozzles?

Ans. Some carburetters are fitted with two or more simple nozzles, the idea being that the several nozzles forming the unit, by coming into action progressively as

the power demand increases, will produce the same effect as though several separate carburetters were used, each in turn being brought into action.

Answers Relating to the Mixing Chamber

Ques. Describe the mixing chamber?

Ans. This consists of a small enclosure or passage-way containing the spray nozzle. The mixing chamber, as its name implies, is the place where gasoline and air are brought together in proper proportions and commingled to form the fuel charge for the engine. It is provided with a main air inlet and auxiliary ports as before described, but the latter are arranged to operate automatically. The outlet to the engine is fitted with a throttle valve, permitting the quantity of the mixture to be varied.

Ques. How is the mixing chamber constructed?

Ans. The construction of the mixing chamber with its appendages follows substantially the arrangement shown in fig. 35. This illustrates a mixing chamber with the spray nozzle A located in the center. The adjustable needle valve E regulates the flow of gasoline to the nozzle. The mixing chamber is open to the atmosphere at its lower end D, through which the **primary** or main air supply enters. A **secondary** or auxiliary air supply is admitted through the opening to the right, being controlled by the valve B which is automatic in its action. The lift of this valve may be varied to meet different requirements, by the adjustable threaded spindle.

Ques. What are the pressure conditions in the mixing chamber?

Ans. In operation, the pressure in the mixing chamber is lower than that of the atmosphere; the degree of vacuum depends on the amount of throttle opening, the engine speed, and the amount of opening for the primary and secondary air supply.

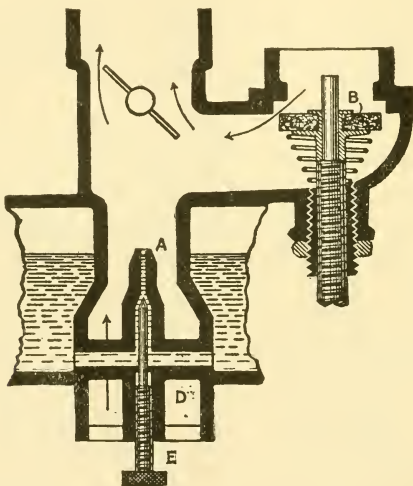

Fig. 35.—The mixing chamber with its appendages. Illustrating, in general, the arrangement of parts, the primary, and secondary or auxiliary air passages; auxiliary valve, spring and adjustment; the spray nozzle with needle valve and the throttle valve. The arrows indicate the direction of the entering air currents and course of mixture.

Ques. What is the behavior of the fuel as it passes the nozzle?

Ans. Gasoline, as it is sucked out of the nozzle, made up as it is of hydrocarbons of different values from the point of view of weight and volatility, will hold to the globular form with more or less tenacity, depending upon conditions.

It should be noted that doubling the diameter of these globules increases their surface four times, but their bulk will be increased eight times.

Evaporation is proportional to the surface, but if double the quantity reside under a given surface, double the time must be taken to gasify the liquid, subject to a correction in that the spheroids are reducing in diameter as the vapor expands. Hence, the importance of constructing the nozzle so that it shall discharge gasoline in as finely a divided state as possible.

Ques. What is the effect of reduced pressure in the mixing chamber?

Ans. Lowered pressure without a correspondingly lowered temperature tends to cause vaporization which begins as soon as the fuel has left the nozzle.

It is impossible to measure or estimate the extent of the vaporization at the nozzle or through the manifold, due to this pressure reduction, but it is known to be very appreciable in its effect.

It should be considered as a condition affecting vaporization at the nozzle end but slightly, but to a much greater extent after the fuel has become suspended in the air.

Ques. What results are obtained with the ordinary nozzle?

Ans. Those who have constructed transparent mixing chambers for the observance of nozzle action, have ascertained that the fuel left the nozzle as a solid stream or in heavy globules and irregular "chunks," not as a fine spray or mist, as it is supposed to do.

Ques. How may this faulty action be overcome?

Ans. A good design of nozzle and needle valve will do much to correct this, giving an increase in power output and fuel economy. However, any nozzle form will give a wet and uneven discharge with low engine demands, even though a true spray may be delivered with increased demands.

Ques. What is the behavior of the fuel in passing through the mixing chamber?

Ans. Some of the fuel torn away is in small enough particles to be considered as spray or mist, and may be taken as contributing directly to the vapor content of the mixture; the greater part, however, sooner or later strikes

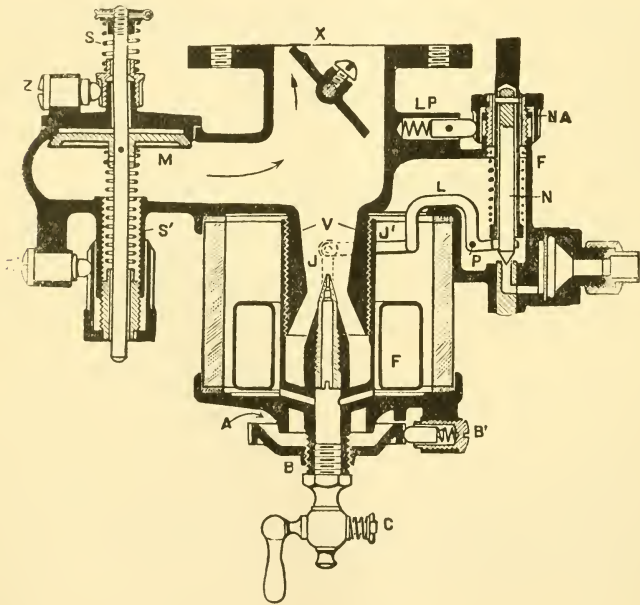

Fig. 36.—The Stromberg Carburetter. The principal features of this carburetter are: a glass float chamber, concentric float, venturi shaped mixing chamber, adjustable primary air inlet, and a two spring adjustment for the auxiliary valve. In operation the gasoline supply is controlled by the float F through the levers J and J'—the latter pivoted at P, and connected to needle valve N. The float point is adjustable by the spring I and nut NA, secured in position by the plunger LP. Primary air enters at A and is regulated by the adjustable cup B, secured by the plunger B'. The drip cock C drains the float chamber. The mixture from the venturi tube receives auxiliary air through the auxiliary valve M, thence it passes to the engine through throttle X. The auxiliary valve is controlled by two springs S and S', the lower one acts on moderate speeds and the upper one on high speeds. The springs have adjusting nuts and self locking devices Z and Z'.

some part of the containing walls, and is later picked up in the form of globules. These globules are continually taken up and thrown out by the air stream in its progress to the cylinders, until some of them are sufficiently small to become permanently entrained or have become completely vaporized.

Ques. What condition of operation has a marked influence on the efficiency of the nozzle?

Ans. Whatever form be given to the nozzle, the effectiveness with which it can break up the fuel varies as the difference between the pressures at its two ends, and as this pressure difference varies throughout the speed range of the engine, the fineness will also vary.

Ques. What provision should be made in designing a nozzle?

Ans. Since the nozzle has a very small opening, even for the largest automobile motors, it is easily stopped up, and the construction should be such that it may be easily removed for cleaning.

Ques. What is a vapor?

Ans. The gaseous form of a substance that is ordinarily solid or liquid; any gas near its condensing point.

Ques. In the carburetter, what governs the degree of vaporization?

Ans. The fineness with which the liquid is broken up at the nozzle; the reduction of pressure within the mixing chamber, and the temperature and grade of the fuel.

Ques. What happens during vaporization by pressure reduction?

Ans. That part of the liquid which vaporizes does so through the abstraction of heat from the remainder, which becomes constantly colder. Vaporization due to pressure

reduction by engine suction will continue until the temperature of the liquid becomes so low that vaporization ceases until heat is supplied from some outside source. Vaporization by pressure reduction, however, can become only partially complete, since the part of the liquid which vaporizes does so through the abstraction of heat from the remainder, which becomes constantly colder.

When a carburetter is rather small, for the engine which it has to supply, it becomes very cold while in operation, as the amount of heat necessary to effect the evaporation of the gasoline is more than is available from the entering air or than could be secured through the metal of the carburetter by conduction. The temperature of the metal becomes so low that water condenses on it, and, in extreme cases, is deposited in the form of frost. This indicates a temperature within the carburetter too low for the successful use of inferior fuel, and so low as to possibly affect the intimacy of the resulting mixture, even if high test gasoline be used. Moreover, if any water be present in the float chamber, it will probably freeze and disturb the flow of the gasoline.

Answers Relating to Methods of Heating

Ques. How is heat supplied to the liquid?

Ans. Heat is given up to the liquid by the air supply, and by radiation from the passage walls.

The transfer is effected chiefly through the agencies of convection and conduction—the former implying a rapid agitation and relative motion between the particles of the two substances, and the latter the exposure of the liquid to the greatest possible surface areas. It is readily seen that the finer the fuel division at the nozzle, the more rapid will be the vaporization and the nearer the approach to uniformity of the final mixture.

Ques. How does vaporization by heat alone proceed?

Ans. Where vaporization is brought about entirely by heat from some outside source, the degree to which it may be carried depends wholly upon the amount of heat

supplied, since the temperature of the liquid is being constantly raised to, or maintained at the proper point.

Ques. How is heat supplied from an outside source?

Ans. By providing means for heating the air supply, the mixture, or the gasoline.

The air may be heated by arranging the outside end of the air inlet pipe so as to terminate closely to the exhaust manifold or some hot portion of the engine.

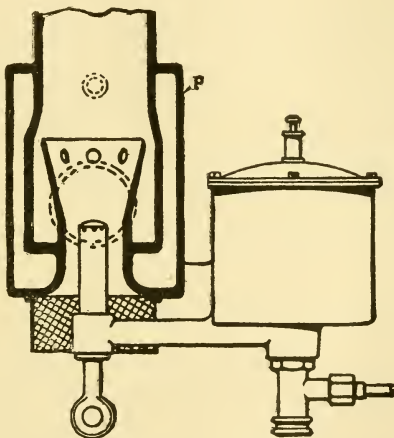

Fig. 37.—A jacketed carburetter. The mixing chamber is shown surrounded by a jacket P, for heating the mixture. This is accomplished either by connection with the cooling water, or exhaust from the engine. During the summer season, when the atmospheric temperature is high, the heating arrangement may be dispensed with.

The mixture may be heated by a jacket around the mixing chamber, (fig. 37), and heat supplied either by means of hot water taken from the cooling system with a shunt, or by passing the exhaust gases through the jacket. Similarly, the liquid may be heated by hot water or exhaust gases by jacketing the float chamber.

Ques. How do the two methods of heating compare?

Ans. Heating the carburetter by the circulating water gives good results, but the starting of the motor is more

difficult, especially in winter. Heating by exhaust gases is open to some objection, as oil and carbon soot are liable to be deposited in the heating jacket.

Answers Relating to the Mixture

Ques. Of what does the fuel charge for a gas engine consist?

Ans. It is composed of a mixture of about ten to sixteen parts air to one of gasoline vapor. The proportion varies according to the conditions of the atmosphere, quality of gasoline, and engine speed.

Ques. What is a constant mixture?

Ans. One in which the proportion of gas and air does not vary.

Ques. Is a constant mixture advisable?

Ans. At first it was thought that the best results were obtained with a constant mixture under all conditions. However, from experience and numerous experiments, it has been conceded that a constant mixture is not advisable, either from the standpoint of fuel economy or best operation.

Ques. How should the mixture be introduced into the cylinder?

Ans. To get the maximum power out of a given sized engine the fuel should be introduced into the cylinders as cold as possible consistent with complete evaporation, intimacy of mixture, and completeness of combustion.

Ques. What is a thin or lean mixture?

Ans. One having a very small proportion of fuel gas.

Ques. What is a rich mixture?

Ans. One having a greater percentage of fuel gas than contained in a lean mixture.

Ques. Which is more economical?

Ans. A lean mixture.

Ques. Does a mixture contain more air than is necessary for its combustion?

Ans. Yes, under average running conditions, at normal loads it is customary to work with a surplus of air of from 30 to 40 per cent.

Ques. Why is this?

Ans. To reduce the temperature all around; and prevent premature explosions which might be caused by the heat of compression; also to supply to the gas, even when poorly mixed with the air, always sufficient oxygen for combustion, and consequently to reduce to a minimum the loss of unburnt gases leaving the exhaust.

Ques. When is a rich mixture desirable?

Ans. At low speeds and under heavy loads.

Ques. Why is this?

Ans. Because at low speeds more heat is lost to the cylinder walls, more compression is lost by leakage, and the combustion can therefore be slower, thus sustaining the pressure. Also with heavy loads a higher mean effective pressure is required in the cylinder; this is secured by the slower combustion, which, as stated, tends to maintain a higher average pressure during the stroke.

Ques. When should a lean mixture be used?

Ans. At high speeds, because the compression is better, due to less time for leakage and to less loss of heat;

moreover, a lean and highly compressed charge burns faster than a rich charge.

Ques. Why is a rich mixture objectionable, especially at high speeds?

Ans. Due to slow combustion, the temperature is too high at the end of the stroke, resulting in rapid deterioration of the exhaust valves; further, there is more or less loss by the continuation of combustion after the opening of the exhaust valves.

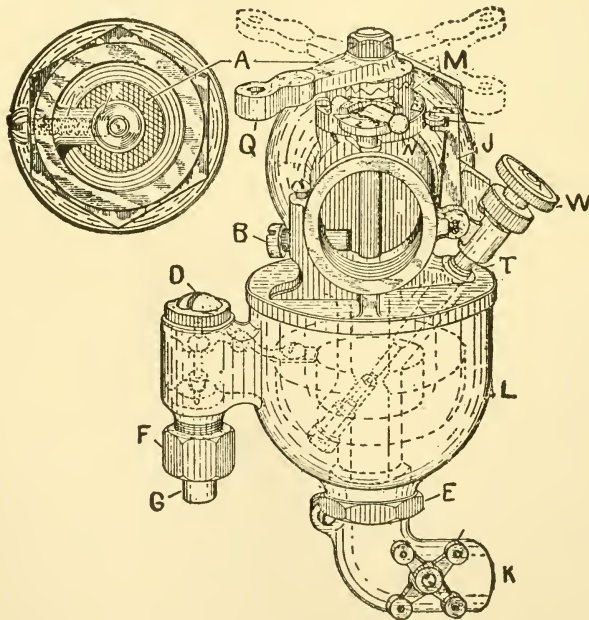

Fig. 38.—Schebler carburettor (model H). It has a spherical shaped bowl which embodies in one the reservoir and float chamber. The primary air passes through the central tube. This tube decreases in size at the discharge point of the nozzle, leaving only a small aperture, thus allowing the engine to be throttled down to a very low speed. The parts are: A, auxiliary air valve; B, low speed adjusting screw; E, float chamber lock nut; F, union; G, gasoline connection; I, float chamber; J, mixing chamber; K, primary air inlet; M, spring cam casting; N, eccentric high speed adjustment; Q, throttle lever.

Ques. How should the engine be operated to reduce this loss?

Ans. By advancing the spark.

Ques. What governs the size of the charge?

Ans. The quantity of mixture that an engine will take varies greatly with the speed. At slow speeds, the volume at approximately carburetter pressure is equal to the cubic content of the cylinders multiplied by the number of power strokes. At high speeds of one thousand revolutions and over, the quantity may drop to less than one-half the theoretical amount, depending upon the design of the valves, inlet piping and carburetter passages.

Ques. How does this affect the operation of the engine?

Ans. This peculiarity reacts upon the compression, and hence on the mixture desired for best results.

It will thus be seen that the design of the engine has a bearing on the carburetter design, which explains the well known fact that a carburetter giving good results on one engine sometimes fails to maintain its reputation when applied to one of different design.

Ques. What feature has a marked influence on the action of the mixture?

Ans. The design and class of ignition; with an efficient spark, the throttle can be more nearly closed, resulting in increased engine capacity and fuel economy.

Ques. How do the different grades of fuel affect the operation of a carburetter?

Ans. These variations demand different sizes of nozzles, different float levels, different amounts of heat to be supplied, and different proportions of air for combustion.

Owing to the absence of a ready means of ascertaining the quality of the mixture being delivered by a carburetter, the majority of motors in use are operating under more or less disadvantageous conditions, even if carefully and properly regulated at the outset.

Answers Relating to the Surface Carburetter

Ques. Describe the operation of a surface or "puddle" carburetter?

Ans. In this method of carburetting, a thin layer of air is passed over the surface of the liquid. The surface

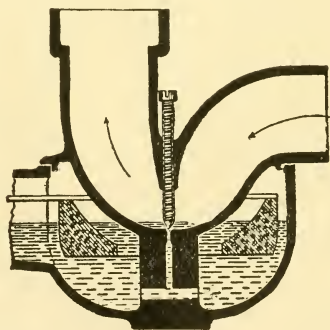
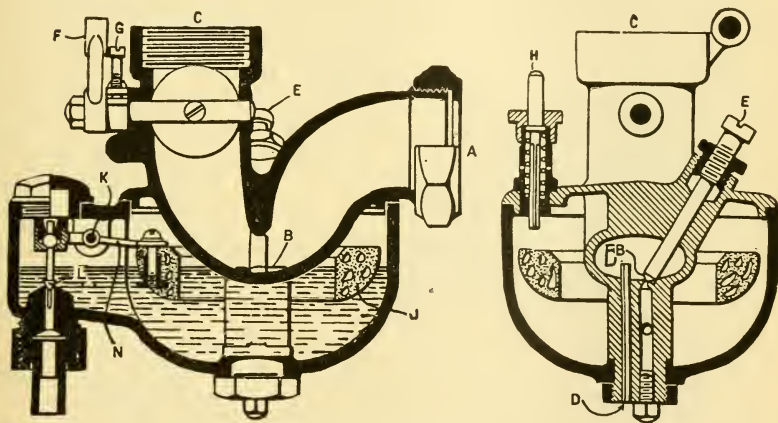

Fig. 39.—The surface or "puddle" type of carburetter. Air flows through the U-shaped tube or mixing chamber as indicated by the arrows. The small puddle of gasoline in the bottom of the mixing chamber is mixed with the air by surface contact. The size or the cross section of the mixing chamber is usually reduced at the region of the puddle so as to increase the velocity of the inflowing air. The gasoline level in the float chamber is maintained slightly higher than the fuel inlet to the mixing chamber, feeding the puddle by gravity. Hence, no initial suction is required to cause a flow of gasoline into the mixing chamber.

carburetter consists of a U-shaped mixing chamber, in the base of which a puddle of gasoline about one-eighth inch deep is maintained by a float feed, as shown in fig. 39. As this puddle is supplied by gravity, a weaker suction can be employed than where the gasoline must be both

lifted and sprayed by suction. This type of carburetter is quite sensitive to changes, both in the float level and in the needle valve adjustment.

An example of surface carburetter construction is shown in figs. 40 and 41. This carburetter has no auxiliary air inlet to become worn. A high air velocity is obtained in the mixing chamber by applying the principle of the venturi tube (later explained).



Figs. 40 and 41.—The Holley Carburetter. This is an example of the surface or "puddle" type. The fuel level is maintained slightly higher than the inlet orifice which causes a small "puddle" of gasoline to form in the bottom of the U-shaped mixing chamber. The operation of this carburetter is described in detail in the text.

Referring to the figures, which show the carburetter in two sections, it will be seen that the air enters at A and passes downward and up through a U-shaped tube, which is constricted at its lowest point. In the floor of the U is the gasoline orifice B, which is regulated by a needle valve E. The mixture passes through a butterfly throttle valve and on to the engine by the connection C. The float cham-

ber surrounds the lowest part of the U, and has an annular cork float J, which controls the gasoline valve L, through a lever N pivoted at K.

When the engine is at rest there is a puddle of gasoline about one-eighth inch deep in the bottom of the mixing chamber. Consequently when the engine is starting or running very slowly the air does not have to lift the gasoline at all but simply draws over the puddle and is carburated by surface evaporation. As the throttle is opened and the air velocity increases the puddle is gradually swept

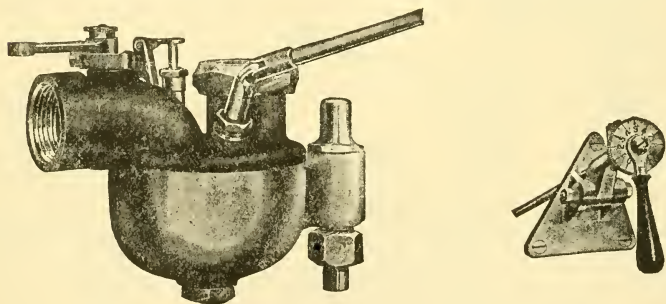

Figs. 42 and 43.—The Holley Surface Carburettor arranged for dashboard control of fuel valve. A universal joint is fitted to the valve stem having an extension connecting with the graduated dial shown at the right. *All carburettors should have dashboard control of the fuel supply.*

away by the strong air current passing over it; at the higher speeds the puddle is wiped out entirely and a spray of the ordinary sort takes its place.

In starting the engine, the float is depressed by the pin H, and to prevent the mixing chamber becoming flooded, a drain pipe D is provided.

The throttle valve is operated by the lever F, and the adjustable stop screw G permits regulation of the opening

for minimum speed. The adjustment is through the **needle valve E**. A dashboard connection is sometimes provided to regulate the opening of this valve.

When there is a dashboard connection the upper end of the needle valve stem has a universal joint, from which a rod extends through the dashboard to a dial and regulating needle. A spring ratchet holds the dial where set, and a hinge permits it to accommodate itself to the angle of the rod. This attachment enables the user to adjust the carburetter under running conditions, a matter of an instant, whereas otherwise he might experiment repeatedly. It also makes it possible to adjust for day to day variations in humidity, temperature, and grade of fuel, as well as to start on a rich mixture and cut down when the engine is warmed up. A special adjustment for hills and sand is also possible.

Answers Relating to "Venturi" Carburetters

Ques. What is the action of a fluid or gas in passing through a tube of variable cross section or size?

Ans. The quantity which passes any section in a given time is the same, but the velocity of the fluid in the various sections is inversely proportional to the areas of the sections. The pressure is greatest at the largest section and least at the smallest.

Ques. What is this effect called?

Ans. It is known as the "venturi principle."

Ques. Has this been applied to carburetter design?

Ans. Yes. The principle has been utilized by shaping the mixing chamber like two hollow truncated cones, as

shown in fig. 44, with their small ends brought together, or, in other words, like the familiar hour glass. By locating the spray nozzle at the point of least cross section, the conditions are favorable for securing that marked economy of fuel which results from the use of high air velocities under low pressures. The greater the pressure drop at

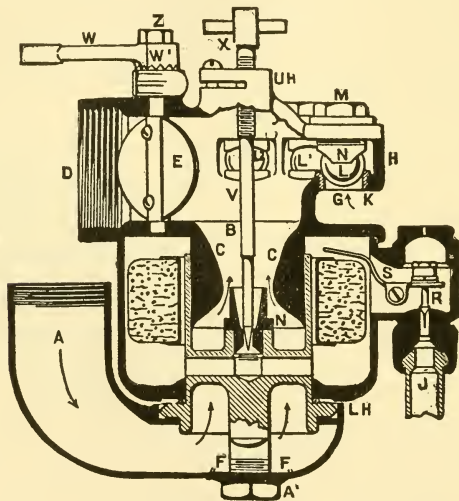

Fig. 44.—The Kingston Carburetter. An example of the venturi type of carburetter. Air enters at A and converges above the nozzle N in the restricted passage, which produces the venturi tube effect. D is the exit to the motor controlled by the butterfly throttle E. Auxiliary air enters through five circular openings G, arranged in a semi-circle in the floor of an extension H of the mixing chamber. Each of these five openings consists of a bushing K threaded in the opening in the extension H, and having its top bevelled to receive a $\frac{3}{8}$ -inch bell metal bronze ball L, which is retained in position by a threaded bushing M, fitting in the top of the extension H. Gasoline enters from the tank through J, controlled by needle valve R, operated through lever S. Complete control of the nozzle N is through the needle valve V, which at the top of the carburetter has a T-piece X, by which it can be raised or lowered, thereby regulating the flow of gasoline. A serrated hub W' of the throttle, permits the handle W to be turned in any direction convenient for the motor, by loosening the locknut Z. Similarly, the intake pipe A, which is a separate casting, can be turned to any desired position by loosening the nut A'.

the nozzle, accompanied by a proportional increase in the air velocity, the better will be the fuel division and vaporization.

The very rapid agitation and internal motion of the mixture column, due to the restricted section of the venturi tube, tends to produce a homogeneous fuel charge. A lowering of the pressure lowers the temperature of the liquid through vaporization, hence, in venturi carburetters where any marked venturi effect is sought, jacketing is advisable.

The advantages of the venturi tube as applied to carburetters may be summed up as follows: Homogeneity of mixture; ease with which the mixing chamber may be jacketed, either by air or water; the mixing chamber may be placed in any plane, thus adapting it to varied engine designs.

How to Select a Carburetter

Automobile owners sometimes seek to improve the efficiency, and at the same time increase the power of their engines by the fitting of new carburetters. Hence, before selecting a carburetter, the buyer should have a clear understanding of its principles. The ideal carburetter requirements are as follows:

1. It must intimately mix in proper proportions the mixture to suit various speeds of the engine.
2. If of the spray type, the air velocity at the nozzle should be great enough at the slowest engine speeds to overcome the initial lift necessary to bring the fuel to the nozzle level and draw it into the mixing chamber.
3. The nozzle should be accessible for cleaning and should be so shaped, together with the needle valve, that it will deliver gasoline in a very finely divided form.
4. The float chamber should be concentric with the nozzle, so that the fuel level at that point will not be disturbed by any inclination of the car.

5. A gauze strainer should be provided at the gasoline inlet and also another at the air inlet.

6. The fuel should flow in a single direction, either up or down through the float chamber so no pockets will exist.

7. There should be a vent in the top of the float chamber.

8. The float point should be easily ground and moved by the motion of the float.

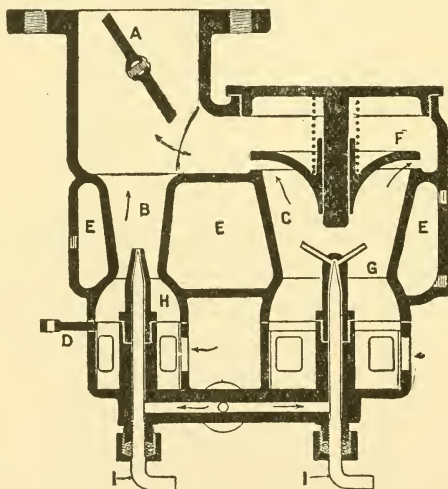

Fig. 45.—The Willet Carburetter. This consists of two carburetters in one, each with its own spray nozzle and adjustment. The small carburetter B is used for low speeds, and a second one, C, cutting in on moderate and high speeds. Automatic action is secured by the spring operated valve F. The air supply of carburetter B may be regulated by the valve D, having dashboard control. Closing this valve produces a strong suction on the spray nozzle in B, thus drawing a rich mixture to make easy starting possible. The valve is then opened to its normal position, which is wide open. Should the weather be cold and a richer mixture required, this valve may be closed somewhat. The entire carburetter is controlled by the butterfly throttle valve A. Nozzle H has a single opening while G is a multi-nozzle having four outlets. Both mixing chambers may be heated by the jacket J. The fuel flow to the nozzle is controlled by the needle valves I.

9. The float should be adjustable to different grades of fuel.
10. The passage between the float and mixing chambers should be large to prevent clogging.
11. The air passage should be contracted at the nozzle.
12. A removable gauze should be inserted in the mixing chamber to prevent unsprayed liquid reaching the engine.
13. The gasoline inlet valve should be arranged to have dashboard control.
14. There should be means of heating in cold weather or with low gravity fuels.

Answers Relating to the Selection of a Carburetter

Ques. In selecting a carburetter, why is it important to determine the correct size?

Ans. The action is unsatisfactory if either too large, or too small.

Ques. If the carburetter be too large, what is the effect?

Ans. Difficulty is experienced in starting, and more fuel is required than necessary because the air velocity through the mixing chamber is too low to cause an intimate mixing of the fuel spray with the air.* Moreover, a very rapid cranking on starting is necessary in order to pro-

*NOTE—It must be remembered that in nearly all carburetters the level of the gasoline in the float chamber being somewhat lower than the nozzle, an "initial suction" is necessary to get the liquid to the point of discharge, and an additional suction to discharge it into the mixing chamber.

duce sufficient suction in the mixing chamber to draw gasoline through the nozzle. A carburetter too large would not only waste fuel, but reduce the power of the engine by furnishing a weak and variable mixture.

Ques. What are the results if the carburetter be too small?

Ans. The engine will not develop its rated power since the carburetter cannot deliver a full charge at high speed. Moreover, as before mentioned, it would become very cold while in operation, as the amount of heat necessary to affect the evaporation of the gasoline is more than is avail-

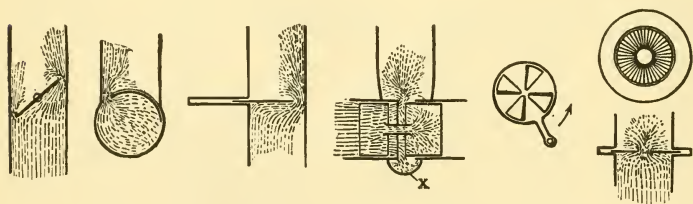

Fig. 46.—Several designs of throttle valves are here shown partially opened, where the effects of separation and deflection of the liquid globules are illustrated for each case. It will be seen that all these throttles act as separators when not fully open. The first four throw the liquid upon the walls unevenly. The last one shown to the right, while better distributing the liquid over the walls, is like the rest, an energetic separator. Throttles like number four are rarely found in later designs. Probably all who have had any experience with this type remember that a drain cock is inserted at X.

able from the entering air, or than could be secured through the metal of the carburetter by conduction. The reduction of temperature may be sufficient to prevent vaporization and affect the intimacy of the resulting mixture. If any water be present, it may freeze and disturb the flow of the gasoline.

Ques. How should the carburetter size be determined?

Ans. By the area of the valve opening on the engine and not by the cylinder displacement.

Ques. Why is this?

Ans. The valve opening area is a true measure of the engine capacity, because a carburetter cannot deliver more charge to a cylinder than the area of the valve opening will allow to pass. An excess passage area, then, cannot cause an engine to deliver more power than it would with a carburetter having a passage equal in area to that of the valve opening.

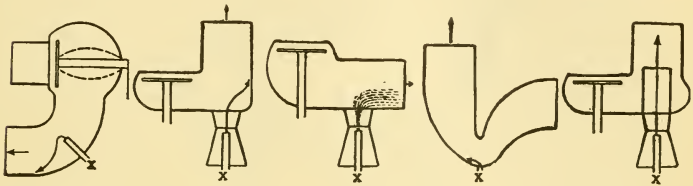

Fig. 47.—A few examples of carburetter design, showing courses followed by the fuel after leaving the nozzle, for different arrangements of parts and passages. The heavy arrowed line leading from the nozzle X indicates the course taken by the mixture as influenced by the design. These diagrams are self explanatory, and show that liquid globules are precipitated against some portions of the mixing chamber wall almost immediately after leaving the nozzle. This tends to disturb the homogeneity of the mixture, and requires that provision be made for correcting this effect in the remaining portions of the passage.

Ques. When is a carburetter of the proper size for a single cylinder engine?

Ans. When the cross sectional area of its outlet is equal to the area of the admission valve opening.

Ques. How is the size determined for a multi-cylinder engine?

Ans. The outlet area of the carburetter is made equal to the area of one valve opening multiplied by the number of inlet valves that are open at one time, as determined from the sequence of cranks.

Ques. Is it advisable to provide more than one carburetter on a multi-cylinder engine?

Ans. No; multiple carburetters are a useless complication, besides a nearer uniform mixture is obtained with only one.

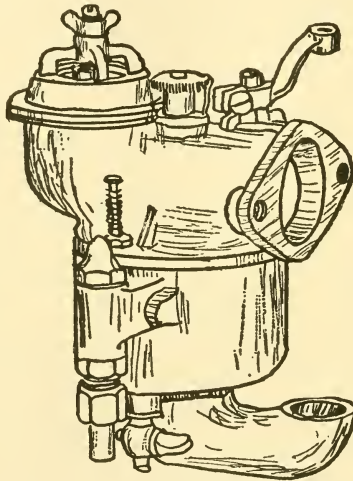

Fig. 48.—The Breeze Carburetter. All adjustments are independent. Gasoline and air adjustments are placed on top, the gasoline valve has figures and graduations stamped on a dial head indicating the degree of feed opening. There is a central draught for the primary air which passes through a venturi tube concentric with the spray nozzle.

Ques. How do carburetter sizes vary?

Ans. Carburetter makers proportion the outlet to correspond to standard wrought iron pipe sizes, as given in the table on page 107. It should be noted that internal pipe diameters do not correspond to the nominal diameters as listed. For instance, a pipe listed as $\frac{3}{4}$ inch has an internal diameter of .82 inch, hence, the correct pipe size should be obtained from the table.

Ques. Knowing *the required outlet area for the carburetter, how is the diameter of the outlet found?

Ans. By reference to the table of standard pipe sizes; a pipe size corresponding as near as possible to this area is selected, taking the nearest larger size.

TABLE OF STANDARD PIPE SIZES.

PIPE SIZE	OUTSIDE DIAMETER	INSIDE DIAMETER	INTERNAL AREA
ins.	ins.	ins.	sq. ins.
$\frac{1}{2}$.840	.622	.304
$\frac{3}{4}$	1.050	.824	.533
1	1.315	1.048	.861
$1\frac{1}{4}$	1.660	1.380	1.496
$1\frac{1}{2}$	1.900	1.610	2.036
2	2.375	2.067	3.356
$2\frac{1}{2}$	2.875	2.468	4.780
3	3.500	3.067	7.383
$3\frac{1}{2}$	4.000	3.548	9.887
4	4.500	4.026	12.730

The successful working of a carburetter depends not only on its being of correct size, but also that it be properly adjusted to the requirements of the engine. The adjustment of a carburetter is an important operation, and should only be attempted by those thoroughly familiar with its principles.

*NOTE.—To find the valve opening area, remove an intake valve and measure the diameter of the port it covers, and also the lift of the valve and angle of valve seat. The effective valve opening area is equal to the slant surface of the frustum of a cone whose upper base diameter is equal to the port diameter, whose slant height is equal to the lift of valve times the sine of the angle of the valve seat and whose lower base diameter is equal to the port diameter plus twice the valve lift times $\cos \phi \sin \phi$. Values thus obtained, substituted in the following formula will give the required area.

Area valve opening = $\frac{1}{2}$ slant height \times (circumference of upper base + circumference of lower base).

This area is to be multiplied by the number of suction strokes occurring at one time.

Answers Relating to Carburetter Adjustments

Ques. What attention should the float chamber receive?

Ans. The interior of the float chamber should be examined, and any dirt or other matter which might interfere with the proper flow of the gasoline should be removed.

Ques. What preliminary operation is sometimes necessary with a spray carburetter, in starting?

Ans. Occasionally, a mixture for starting must be obtained by priming; it is, however, possible in doing this to make too lean or too rich a mixture. If the adjustments be decidedly wrong, the mixture formed on the first few revolutions will be so bad that the engine will stop.

Ques. What adjustment is necessary for the float?

Ans. If the float be too high, gasoline will continually overflow the spray nozzle. The gasoline level, as before stated, should be such that the liquid will form a bubble at the nozzle to be blown off at will. The exact height can be found by this method.

Ques. What should be noticed after the float chamber has had time to fill?

Ans. It should be observed whether gasoline drips from the nozzle. Occasionally a float and float valve are so arranged that the valve, although tight in one position, may slant over a trifle and leak.

Ques. How is a proper mixture obtained for starting the engine?

Ans. If there be no dripping from the nozzle after the float chamber has had time to fill, the float should be depressed, and the engine cranked at the first sign of dripping.

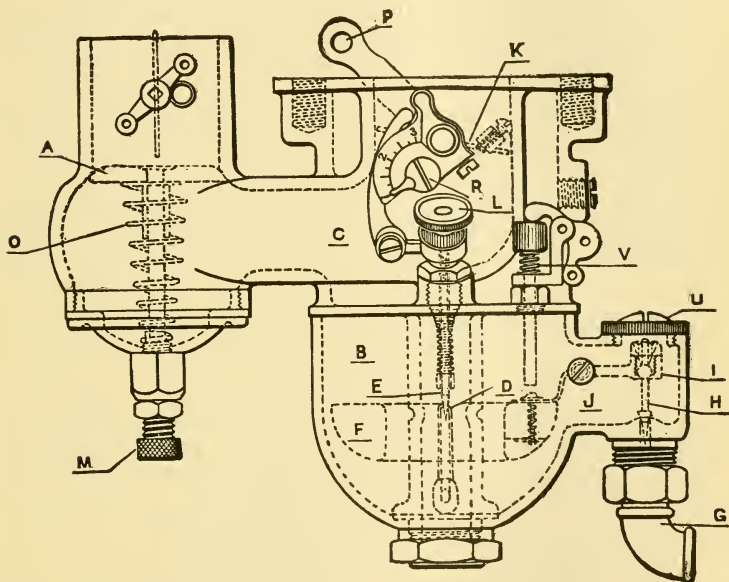

Fig. 49.—The Schebler Carburetter. A compensating air valve A, adjustable by the screw M and the spring O, controls the air supply to the mixing chamber C. Above this valve is a shutter which may be partially closed when cranking to increase the suction in order to obtain a rich mixture. The spray nozzle is located at D and the supply regulated by the needle valve E by means of a thumb wheel L. The needle valve has two adjustments, one for high speed and one for low. At R is the eccentric high speed adjustment. Throttle valve K is of the butterfly type and is operated by the lever P. Heating is secured by a jacket surrounding the throttle. Gasoline enters the float chamber B through the elbow connection G. The fuel level is maintained by the concentric float F, which regulates the supply by the inlet valve H and the lever connection J. The float point is adjustable by the needle valve adjusting screw I, accessible by removing cap U. The carburetter is primed by the tickler or flushing pin V.

In case of too much priming the gasoline should be shut off and some of the supply in the float chamber removed, to weaken the mixture. Experience will soon establish the priming required to start the engine, when cold.

Gasoline, when warm, evaporates more rapidly, and caution is required not to prime too much. Many carburetters with a small primary air passage will start the engine without priming, when they are once properly adjusted.

When the engine starts, but immediately dies down, the float should be depressed, as this keeps the engine going if the cause of the dying down be too weak a mixture.

Ques. With what degree of throttle opening should the engine attain its maximum speed when running free, and with the spark fully retarded?

Ans. Under these conditions, the engine should attain its maximum road speed with the throttle about one-eighth open.

Ques. What should be the action of the auxiliary valve controlling the secondary air supply?

Ans. The auxiliary valve should begin to open at about 250 revolutions per minute, but should not open fully for maximum speed with engine running light, as it is not taking full charges.

Ques. What is the first adjustment of the fuel?

Ans. With the engine running light at about 250 to 300 revolutions per minute, the fuel needle valve is adjusted to such a position that with the spark just back of the center, the speed can be cut down to below 200 revolutions per minute without misfiring.

Ques. What is the first adjustment of the auxiliary valve?

Ans. The spring should be adjusted so that it only partially opens for maximum speed when the engine is running free.

Ques. What is the adjustment to be made on the road?

Ans. The fuel supply. In making this adjustment the car is run at moderate speed. Now should the engine run in a sluggish manner, the gasoline supply must be varied, first reducing, then increasing the richness of the mixture. A few trials should give a mixture on which the car will run well.

Ques. Does the satisfactory running of the car prove the correctness of the mixture?

Ans. No, not altogether, because the car may be running with more throttle opening than is necessary.

Ques. How is an over rich mixture indicated?

Ans. If the mixture be too rich, the radiator will heat up on level ground and overheat on hills at moderate speeds.

Ques. How should the mixture be weakened?

Ans. By reducing the tension of the auxiliary valve spring.

Ques. What indicates that the mixture is too lean?

Ans. A weak action of the engine not accompanied by heating, when running the car on level ground.

Ques. Describe a good test of the mixture?

Ans. Its quality is indicated by the response to the advance of the spark. If the mixture be bad, the spark must be advanced considerably to produce any noticeable acceleration, whereas with the correct mixture any change in the advance is not needed except at maximum speeds. Even more marked is the response to the throttle when the latter is nearly closed.

Ques. What peculiarity is there in the action of the auxiliary valve spring?

Ans. A change in spring tension has a greater proportional effect at low than at high speeds.

Ques. How should the auxiliary valve spring be tested?

Ans. After removing the exhaust manifold, the flame colors should be observed, as these are reliable indications of the quality of the mixture. The stiffness of the spring should be such that at the lower and medium speeds the

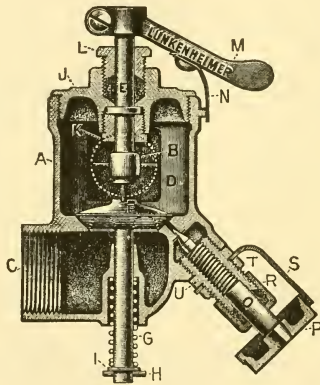

Fig. 50.—A Vaporizer or Generator Valve. This differs from a carburetter in the absence of a float chamber, and consists of a mixing chamber containing a check valve and having: 1, an air inlet; 2, a gasoline inlet; and 3, an exit to engine. Its operation is as follows: On the suction stroke, the partial vacuum produced in the mixing chamber A permits the atmospheric pressure to act upon the valve F, opening same against the tension of spring G, which is held in position by the washer I and cotter H. At this period, the gasoline valve in the port seat is uncovered and a small amount of gasoline is sprayed into the incoming volume of air and passes into the mixing chamber where the mixing is further assisted, in some designs, by baffle walls. At the end of the suction stroke the pressure in the mixing chamber becomes equalized with the atmosphere and the spring causes the valve F to seat, thereby retaining the mixture and shutting off any further injection of gasoline or air. The gasoline supply may be adjusted by the needle valve O operated by the thumb wheel P, which has a flat spot on its circumference on which the spring S bears to retain the adjustment. The spring can be turned to any position by loosening the locknut T. The volume of mixture to the engine is regulated by a sliding throttle D, operated by lever M and locked by spring N, which engages notches in a graduated dial. A vaporizer when used on a two cycle engine requires no check valve between it and the engine.

color of the flame will be a dark blue verging upon violet; for other speeds up to the normal or rated speed of the engine, the color should be a somewhat lighter blue, the color gradually fading but at no point losing its decided blue tinge.

The fading of the blue color denotes a gradual weakening of the mixture as it should do for increasing speeds. One necessity, among others before explained, for this gradual weakening is that at high piston speeds a slightly weakened mixture burns faster than does one of full strength. This being necessary at high speeds to secure complete combustion before exhaust.

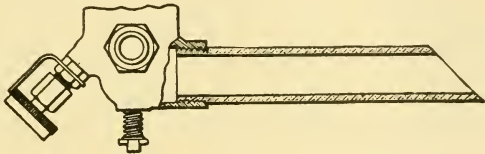

Fig. 51.—An Air Inlet Pipe. This consists of a short length of pipe threaded at one end and screwed into the air inlet of a vaporizer. A saving in fuel is secured by its use as any gasoline or vapor that may be blown into the inlet when the valve seats, is retained in the pipe and drawn into the mixing chamber during the next suction stroke. Without any extension of the inlet, this fuel would be blown out into the atmosphere and lost.

Ques. What is the significance of a yellow or red tint?

Ans. A yellow tint in the exhaust denotes too little gasoline in proportion to the amount of air supplied, while red indicates too much gasoline. Both these tints, yellow and red, show that the engine is not developing its best power, moreover, the red shows a waste of fuel.

Ques. What indicates a faulty nozzle action?

Ans. This defect makes it impossible to adjust the carburetter so as to get a blue flame; it is further emphasized

by fluctuations of the flame color from yellow to red or vice versa, indicating coarseness of fuel division and a resulting non-homogeneous mixture. The nozzle may not be entirely at fault; as the mixture is somewhat dependent upon the manner in which the carburetted primary air is brought into contact with that from the auxiliary port; but whatever the whole cause of the trouble may be, the nozzle is chiefly at fault.

Ques. What indicates that the spring is not properly proportioned for the auxiliary valve?

Ans. Sometimes a spring adjusted to give a proper mixture at one speed will not give good results at other speeds. Assuming the mixture originally to be too rich at high speeds, and that it was corrected by slackening the spring or increasing the auxiliary valve lift, and also that the change was only in the lift, the mixture at lower speeds has probably not been affected. If, however, the spring has been slackened, the mixture may be too lean at low speeds, owing to the air valve opening too soon. One way to correct this would be to use a spring having a larger number of turns, but a satisfactory result may usually be reached by increasing the spring tension and reducing the spray orifice.

Ques. What further attention should be given to the auxiliary valve?

Ans. It should be noted whether the valve strikes the stop at moderate speed. If it do, it will not admit sufficient air at high speed, hence, the stop should be adjusted if possible to permit a greater lift. If it should "flutter" at high speed, the lift must be reduced to increase the spring tension and diminish the fuel supply to the nozzle.

Much depends upon the proper adjustment of the air valve spring. To get the best results in power and economy, the tension of the spring should be almost nothing with the valve upon its seat; and, if the primary air inlet and fuel valve be carefully adjusted as above, it will be found that no more tension is needed to maintain the valve in a closed position while starting the engine. The spring may not be composed of the proper size wire nor have the right number of turns to give the proper initial tension.

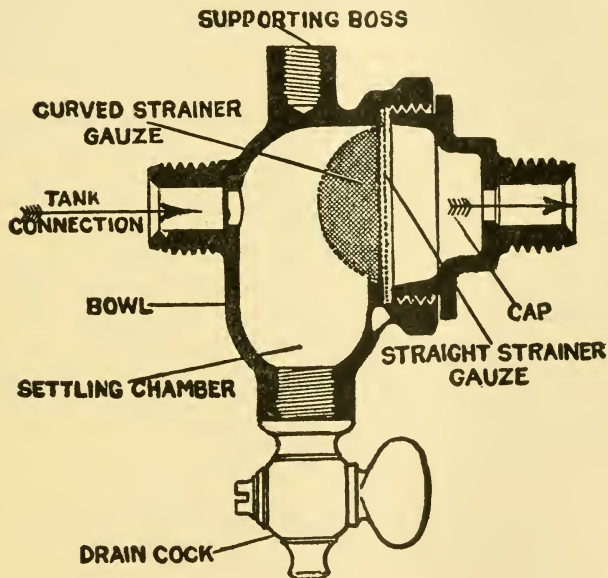

Fig. 52.—The Breeze fuel strainer. In this device the fuel settles first and then strains through fine meshed gauze. The sectional cut shows the construction. Two gauges are furnished, one vertical across the inside of the small chamber and the other rounded out. Water, dirt, etc., settles before the fuel gets to either gauze. To take apart and clean the strainer, the front and back parts are unscrewed. Occasional draining is all that is necessary under ordinary conditions to let out the dirt and water. The holes in the end are drilled to take $\frac{1}{4}$ in. outside diameter copper tubing, which can be soldered into the ends of connections. The ends could also be drilled to take $\frac{1}{8}$ in. outside diameter tube. The outside ends are threaded $\frac{1}{4}$ in. iron pipe size, so that a regular union nut and tube can be used. The arrow on the side points in the direction the gasoline should flow; that is, the arrow points toward the carburetter. The boss on the top is tapped $\frac{1}{4}$ in. standard bolt thread and may be used for supporting the weight of the strainer and the pipe line.

Ques. How can the "road adjustments" be made without running the car on the road?

Ans. A device consisting of a rude form of Prony brake has been employed to secure a running load on the engine with the car standing.

In this method of making the adjustments, a board five or six feet in length and somewhat wider than the fly wheel face is either suspended from the side frame of the car or fulcrumed upon a block on the floor. The short end of the lever thus provided bears against the flywheel from the under side and weights up to ten or fifteen pounds are placed on the other end; this will give all the load necessary.

With this apparatus the carburetter may be adjusted to the varied road conditions of power demands while the car is standing.

Ques. What precaution should be taken in making carburetter adjustments?

Ans. They should not be made hurriedly, as the first indication of the nature of a trouble may prove, on further investigation, to be wrong. When a fairly good mixture has been obtained, it is advisable to operate the car awhile without further adjustments, noting its action and carefully analyzing the carburetter action under all road conditions.

Answers Relating to Hand Control

Ques. Do the automatic devices employed on carburetters give proper regulation for all conditions?

Ans. All attempts at automatic regulation to secure the ideally correct mixture of gasoline and air, for every variation in engine speed have not been successful.

Whatever may be the claims of carburetter makers, they would be the first to admit that, excellent though the results may

be in the hands of the average user, these results at best are but a compromise. Many of the best known European cars have built up reputations by being driven in and winning races on the road, by drivers recruited from the ranks of those who first obtained publicity by track and road racing on motor bicycles having carburetors with hand control. There is no sound reason why a driver, in addition to the throttle, should not have two other levers within reach to alter the quantity of air passing by the nozzle and the quantity of gasoline sprayed into the mixing chamber. Once the correct gasoline supply for the jet is settled at the factory it would not require to be greatly varied; therefore, an attachment on the dashboard providing minute gradations would suffice.

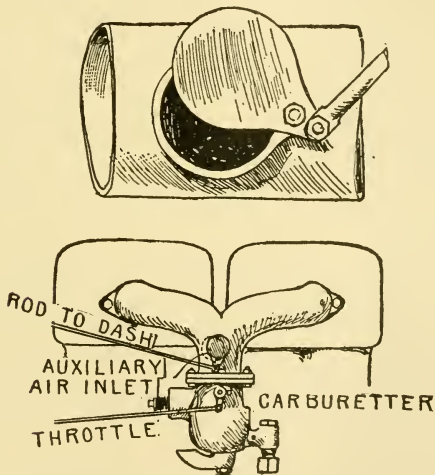

Figs. 53 and 54.—Hand control for extra air supply. A very useful attachment for economy of fuel, and for cooling and scavenging the cylinders.

Ques. Under what running conditions is it desirable to use hand control?

Ans. Hand control can be used to advantage in ascending steep hills when the engine load limit is nearly reached, necessitating wide open throttle and retarded spark. The automatic auxiliary air supply ought, under these circumstances, to promptly close, but the great suction exerted by a four or six cylinder engine on full throttle keeps the

air valve open much wider than is necessary. The engine demands the richest possible mixture, and this ought to be supplied, because the certain overheating that will ensue is only temporary, and may be nullified either by stopping the engine when the hill is surmounted, or by replenishing the circulating water.

The abolition of hand control for the auxiliary air supply is only for simplicity, for, with or without a variable jet, hand control offers a command of engine flexibility little short of wonderful. It is interesting to watch the spindle of an automatic air valve when the throttle is opened and closed, the car, of course, being at a standstill. The valve will, in nearly every case, be found to gradually open as the engine speed increases in response to the throttle reaching its full opening at about three-quarters speed. At the highest speeds, the engine requires considerably more air than is needed at the lower speeds, and this is not obtained with automatic control.

Ques. Describe a simple device for hand control that may be easily applied to any car.

Ans. An opening is cut at any suitable place in the pipe between the carburetter and engine and covered with a sliding collar, valve, flap, or any other device that can be easily opened or closed by a lever on the steering column, the essential feature being that it must be fairly air tight in the closed position.

With a little experience on the road, the driver will soon discover the point of engine speed determined by the throttle lever at which he can commence to open the extra air supply. If he has never before driven a car so fitted, it will be a revelation to him, for this extra air port can be opened wider and wider before the engine will misfire to indicate that the mixture is too weak.

Ques. What other duties may be performed by the port cut for hand control?

Ans. It can be made to act as a scavenger and cylinder cooling agent. When descending a long hill, by switching off the spark, entirely closing the throttle and opening the

extra port to its full extent, (the top speed gear and clutch are, of course, kept in engagement so that the car is driving the engine), cold air is drawn into the engine on each suction stroke, clearing out every particle of the hot gases and helping materially not only to cool the engine and spark plugs, but also to keep the points of the latter much cleaner and freer from carbonized oil than would otherwise be the case.

Carburetter Troubles

Preliminary to hunting for carburetter troubles, it should be ascertained that there is some gasoline in the tank, and that the valve on the pipe leading from same is open.

The carburetter is too often blamed for faulty engine performance, which should be attributed to defects in the ignition system. Such symptoms as fouled plugs, black smoke in the exhaust, etc., point at once to the carburetter, but in cases where such obvious signs are wanting, the ignition system should first be thoroughly examined.

The following carburetter troubles are frequently encountered; they are for the most part due to inattention or carelessness, rather than to defective mechanism.

No Flow of Gasoline.—Sometimes little, if any, gasoline will flow to the nozzle even when the carburetter is flooded in the usual manner. A quantity of dirt sufficient to stop the flow of gasoline, may have gathered on the wire gauze in the supply passage.

The gauze and also the float valve, spray nozzle, and connecting passage should be cleaned. In removing the needle valve to clean the spray nozzle there is no need of losing the

adjustment, as after the set screw which locks the adjustment is loosened, the needle may be turned down to a complete close, and the number of turns required noted, from which the old setting may be again obtained.

Flooding.—If not caused by a defective float, the float valve should be examined for imperfect seating. If a carburetter be not well stayed, vibration may keep the float valve off its seat, and continuous flooding result therefrom.

The leak may usually be stopped by grinding the valve on its seat with a little whiting, or even grinding the seat and valve together without any abrasive, holding the valve and seat in their

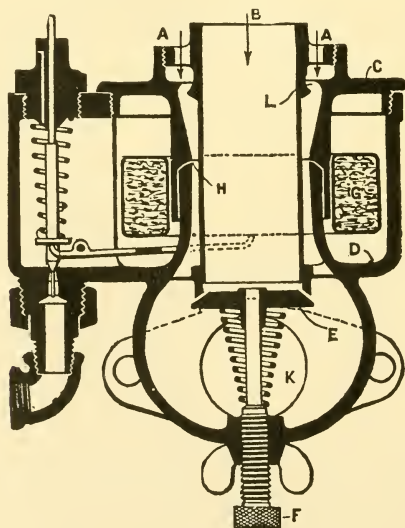

Fig. 55.—The Brock Carburetter. Primary air enters through a ring opening A, and flowing downward, as indicated by the arrows, meets the gasoline which enters through the slit opening H in the walls of the mixing chamber, the outlet to engine being at K. The gasoline opening H may be adjusted by screwing up or down the top piece C or cover of the float chamber. The float G maintains a level in the float chamber D, approximately $\frac{1}{8}$ inch below the gasoline opening H. At B is the secondary air inlet, controlled by the auxiliary valve E, having an adjusting screw F. The float point has spring adjustment as shown.

true relative positions, and giving them a motion or rotation with moderate pressure.

Carburetters having offset float chambers may flood when the car is not level, as, for instance, when standing on a grade.

Flooding may be caused by dirt under the float valve; this can often be removed by depressing the float, thus opening the float valve and flushing.

Leaking Float.—Persistent flooding is frequently due to this cause. The presence of liquid inside a metal float is detected by shaking it, and the hole through which it entered located by heating the float and passing a lighted match over the surface, which will ignite the issuing vapor.

To repair, the hole is enlarged with an awl, the float drained, and soldered.

Leaking Tank.—Tanks are liable to leak through the opening of the seams by jarring or vibration.

Galvanized iron tanks, such as are furnished on some machines, should be discarded when a leak results from rust, as it is practically no use to solder it. A heavy gauge copper tank should be substituted.

The supply pipe should be made flexible by a loop to avoid strains due to vibration. All soldered connections should be inspected from time to time.

Loss of Buoyancy.—A cork float sometimes loses its buoyancy by becoming saturated with gasoline.

It should be removed and thoroughly dried by placing the float in a warm place; after drying a coat of shellac should be applied.

Impure Gasoline.—Many carburetter troubles would be avoided if more care were taken to free gasoline of all dirt before its entrance into the tank.

When filling the tank, a strainer funnel should be used. A piece of chamois skin makes an excellent filter; if a wire gauze be used it should have a very fine mesh. In the absence of a strainer funnel, three or four layers of fine linen fitted inside an ordinary funnel may be used. The same funnel should never be used for both gasoline and water.

Stale Gasoline.—When a car is not used for some time the gasoline in the float chamber loses its strength.

If the engine should not start, the tank valve should be closed, and the carburetter drained through the pet cock, which is usually provided in the bottom of the chamber for this purpose. When empty, the pet cock should be closed and the tank valve opened, not forgetting to give the float chamber time to fill before trying to start the engine.

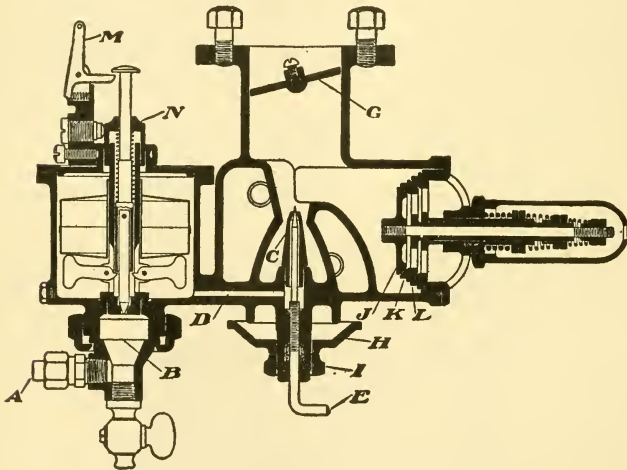

Fig. 56—The D. K. W. Carburetter. In operation, gasoline enters at A, and passes upward through screen B, and then through the float valve to the float chamber. From the float chamber the gasoline reaches nozzle C through passage D. The flow of gasoline through C is regulated by the needle valve E; G is the throttle. The primary air is adjustable by cup H which is locked in place by nut I. The auxiliary air enters through air valves J, K, and L. These are held closed by springs but are progressively opened as the engine suction increases; a water jacket is provided for heating.

Low Grade Gasoline.—This sometimes causes the engine to misfire and not develop its full power. Inferior fuel is generally indicated by a smoky exhaust and a disagreeable odor. Gasoline suitable for automobile use should test 76 degrees, or not much below this gravity.

In the absence of a testing outfit, the quality of the liquid may be ascertained by pouring a little on the hand. If it evaporate rapidly and leave the hand dry and clean it is acceptable. but if it evaporate slowly and leave a greasy deposit, it should be rejected. This furnishes a fairly reliable indication.

Water in Gasoline.—This is generally indicated when the engine runs irregularly, and finally stops.

To test, a small quantity of the gasoline is placed on a clean knife blade or other smooth metallic surface. The gasoline will evaporate, and if water be present it will collect in small globules unless the water has been purposely chemically combined with the gasoline. Gasoline and water chemically combined will burn slowly with a yellowish flame.

Freezing of Carburetter.—When water enters the float chamber it settles to the bottom and in cold weather prevents the action of the float by freezing; the water is also liable to enter the spray nozzle where it may congeal. When heavy demands are made on a carburetter it becomes very cold, as the heat required to effect evaporation is much more than that available from the entering air. Under extreme conditions moisture is deposited in the form of frost, indicating a temperature in the carburetter too low for good working.

These conditions may be avoided by jacketing or heating the air supply.

Cold Weather.—In extremely cold weather it may be necessary to warm the carburetter and admission pipe. This may be done by pouring boiling water over them.

Cranking.—So far as carburetter action is concerned, a few quick turns of the crank will be more likely to start the engine than ten minutes or more of slow grinding.

Misfiring.—This is frequently caused by too weak, or too rich a mixture. Misfiring allows the unburnt charge

to accumulate in the exhaust pipe and muffler; sometimes accumulated gas is ignited by a later charge, causing a very loud report like a tire explosion. Misfiring on slow speed may be caused by too weak a mixture due to having the float set too low, or by leaks in the pipe and connections between the throttle and the engine.

After Firing.—This is usually caused by the delayed ignition or combustion of the previous charge, due to a mixture that is too rich or too weak, hence it burns slowly with continued combustion after passing into the exhaust.

Weak Explosions.—Quite regular, but weak explosions may be due to either too rich, or too poor a mixture, or to the loss of compression.

A hiss inside the cylinder indicates a leaky piston ring, or that the openings of the piston rings are in line.

A little soapy water around the relief cock, spark plug, or other opening into the combustion space will indicate a loss of compression by the formation of bubbles.

IGNITION

It is of prime importance that the automobilist acquire a thorough knowledge of ignition. Many of the troubles still encountered, notwithstanding numerous improvements, have arisen from failure of the ignition system to perform its proper function. The engine may operate with an imperfect fuel mixture, if the ignition system be in working order, but any defect in the latter will in nearly every case cause the engine to misfire or stop.

Numerous devices have been tried to fire the charge in gas engines. In the early days, a flame behind a shutter was used, the latter being opened at the proper moment. Sometimes the flame was blown out by a too violent explosion, so this method gave way to a porcelain tube that was kept at white heat by an interior flame. The tube being subject to breakage, spongy platinum, heated by compression, was next tried and found to work, if not too moist from watery vapor in the gas mixture, or if the engine speed were not too high. Electricity is now universally used. Hence, in order to gain an understanding of ignition principles, it is necessary to have at least an elementary knowledge of electricity, of which a brief outline is here given.

Answers Relating to Electricity

Ques. What is electricity?

Ans. The name **electricity** is applied to an invisible agent, known only by its effects, and the various ways in which it manifests itself.

Electrical currents are said to flow through **conductors**. These offer more or less **resistance** to the flow, depending upon the material.

Ques. What material is generally used for conductors, and why?

Ans. Copper, as it offers little resistance to the flow of the electric current.

Ques. How is electricity transmitted by a conductor?

Ans. It is now thought that the flow takes place along the surface and not through the metal. The current must have pressure to overcome the resistance of the conductor and flow along its surface.

This pressure is called **voltage**, caused by what is known as **difference of potential** between the source of the electric current and the terminal.

Ques. What units are employed to measure an electric current?

Ans. The pressure under which the current flows is measured in **volts**, and the quantity that passes in **amperes**. The resistance with which the current meets in flowing along the conductor is measured in **ohms**.

These terms are further explained hereafter.

Ques. Upon what does the flow depend?

Ans. Upon the pressure and the resistance.

The flow of the current is proportional to the voltage and inversely proportional to the resistance. The latter depends upon the material, length, and diameter of the conductor.

Ques. What is the natural direction taken by the current?

Ans. It always flows along the path of least resistance.

Ques. What precaution is necessary?

Ans. The current should be so guarded that there will be no leakage.

Ques. How is leakage avoided?

Ans. The wires are **insulated**, that is, covered by wrapping them with cotton or silk thread or other insulating materials.

Ques. What is a short circuit?

Ans. A defect or **fault** in the insulation which allows the current to leak, and return to "the source" without doing its work.

Ques. What names are given to the two conductors which transmit the current?

Ans. The conductor which receives the current from the source is called the **lead**, and the one by which it flows back, the **return**.

Ques. What is the distinction between a metallic and a ground circuit?

Ans. When wires are used for both lead and return, it is called a **metallic circuit**; when the metal of the engine is used for the return, it is called a **ground circuit**.

The term originated in telegraphy, where the earth is used for the return. In ignition diagrams then, the expression "to ground" means to the metal of the engine.

Ques. What property of electricity makes it available for ignition?

Ans. The fact that whenever its motion is stopped by interposing a resistance, the energy of its flow is converted into heat.

Ques. How is this accomplished?

Ans. In two ways: 1, by suddenly breaking a circuit, and 2, by placing in the circuit a permanent **air gap** which the current must jump. In either case, the intense heat caused by the enormous resistance interposed, instantly produces a spark, which ignites the charge.

Ques. What names are given to these two methods of producing the spark?

Ans. The first is known as the **make and break** or **low tension**, and the second, the **jump spark** or **high tension**.

Ques. How are the various kinds of electric currents distinguished?

Ans. An electric current is said to be: 1, **direct**, when it is of unvarying direction, 2, **alternating**, when it flows rapidly to and fro in opposite directions, 3, **primary**, when it comes directly from the source, 4, **secondary**, when the voltage and amperage of a primary current have been changed by an **induction coil**, and 5, **low tension**, or **high tension**, according as the voltage is low or high.

Ques. How do high and low tension currents vary?

Ans. A high tension current is capable of forcing its way against considerable resistance, whereas, a low tension current must have its path made easy.

Ques. Describe an easy, and a difficult path.

Ans. A continuous metal path is an easy one, but an interruption in the metal, as the permanent air gap of a **spark plug**, is difficult to **jump**. Air is such a poor conductor that it is usually spoken of as a **non-conductor**.

The latter term should not be encouraged, as, strictly speaking, there are no non-conductors; the word insulator is to be preferred.

Ques. How does a low tension current produce a spark?

Ans. The low tension current is only able to produce a spark when parts are provided in the path, and so arranged that they may be in contact and then suddenly separated. The low tension current will, as the separation occurs, tear off very small metallic particles and use these as a **bridge** to keep the path complete. Such a bridge is called an **arc**, the heat of which is used for ignition.

The ancients applied the word "magnet," **magnes lapes**, to certain hard, black stones, which possess the

property of attracting small pieces of iron, and, as discovered later, to have the still more remarkable property of pointing north and south when hung up by a string; at this time the magnet received the name **lodestone**.

Answers Relating to Magnets and Magnetism

Ques. What are the **magnetic poles**?

Ans. The two regions in which the magnetic property is strongest.

Ques. Where are the poles of a magnet?

Ans. In a long shaped magnet, they are at the ends; half-way between the poles there is no attraction at all.

Ques. What names are given to the poles?

Ans. In a bar magnet, that end which tends to point towards the north is called the **north** or **positive** pole, and the other, the **south** or **negative** pole.

Ques. What change takes place when a current of electricity passes through a wire?

Ans. What is known as a **magnetic field** is produced.

Ques. What is an **electro magnet**?

Ans. A magnet produced by passing an electric current through an insulated wire conductor coiled around a core of soft iron.

Ques. How will the action differ with an iron or steel bar?

Ans. If the bar be of soft iron, it will be very strongly magnetized, but will not retain its magnetism for any length of time after the current ceases to flow; if of steel,

it will not be magnetized so strongly nor so quickly, but will retain its magnetism for a greater length of time after the current is shut off.

Ques. Does it make any difference how the wire is wound around the bar?

Ans. Yes, it should be wound continuously in one direction, as the polarity, or location of the poles of the bar, depends upon the way the current flows through the wire.

Ques. How may the polarity of a magnet be determined?

Ans. If the current pass around the magnet clockwise the magnetic flux will be away from the observed end.

The poles may be identified by holding a permanent magnet, or a compass needle, near one pole of the electro-magnet; the north pole of one will attract the south pole of the other, and *vice versa*.

If the coil of an electro-magnet be surrounded by a second insulated coil of wire an **induced current** is produced in this second coil by what is known as **induction**, each time the current in the inside coil begins or ceases flowing. The inside coil is called the **primary winding**, and the outside coil the **secondary winding**. Similarly, the current passing through the inside coil is called the **primary current**, and that in the outside coil, the **secondary** or induced current.

By varying the relative number of turns in the two coils the tension or voltage of the two currents is changed proportionately. That is, if the primary winding be composed of ten turns and the secondary of one hundred, the voltage of the secondary current is increased approximately **ten times** that of the primary. This principle is employed to produce the extremely high tension current necessary with the jump spark method of ignition.

Answers Relating to Methods of Generating Electricity

Ques. What methods are there of producing an electric current?

Ans. An electric current may be produced by: 1, chemical, and 2, mechanical means.

Ques. Describe the first method.

Ans. In producing electricity by chemical action, two dissimilar metals, such as copper and zinc, called **electrodes**, are immersed in an exciting fluid or **dielectric**. When the electrodes are connected at their terminals by a wire or conductor, a chemical action takes place, producing a current which flows from the copper to the zinc. That terminal from which the current flows is called a **plus** or **positive pole**, and the other electrode terminal a minus or **negative pole**.

Ques. What name is given to this device?

Ans. It is called a **cell**, and the combination of two or more connected so as to form a unit, is known as a **battery**.

The word "battery" is frequently used incorrectly for a single cell. It requires more than one cell to form a battery.

Ques. How are cells classified?

Ans. They are classed as **primary** or **secondary**, according as they generate a current of themselves or require to be charged from an external source. In the latter type a current is stored, which is afterwards yielded in the opposite direction to that of the charging current.

Ques. Name two methods of producing an electric current by mechanical means.

Ans. By a dynamo, or a magneto.

Ques. What is the difference between a dynamo and a magneto?

Ans. A dynamo has an **electro-magnet**, known as a **field magnet**, which produces a **magnetic field**, and an **armature** which, when revolved in the magnetic field, develops electric current. A magneto has, 1, a **permanent magnet** to produce the magnetic field, and 2, an **armature** which is

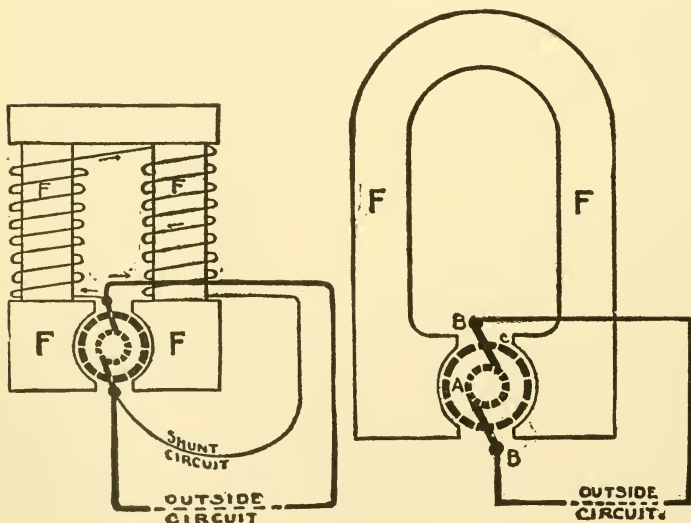

Figs. 57 and 58.—Circuit diagrams to illustrate the difference between a dynamo and a magneto. The former has its field magnets FF magnetized by means of a small current flowing around a shunt circuit. In a magneto the field magnets are permanently magnetized. The strength of the field of a magneto is constant, while that of a dynamo varies with the output, hence, a magneto may be run at a widely varying speed and meet ignition requirements, but a dynamo must have its speed maintained approximately constant to keep the voltage within limits.

usually arranged to revolve between the poles of the magnet. The basic principles upon which dynamos and magnetos operate are the same.

Ques. Into what classes are magnetos divided?

Ans. They are divided into two classes: 1, **low tension**, and 2, **high tension**, according as they generate a current of low, or high voltage.

Low tension magnetos are used for **make and break ignition**, and the high tension type for the **jump spark system**. A low tension magneto in combination with a secondary induction coil may be used to produce a high tension spark.

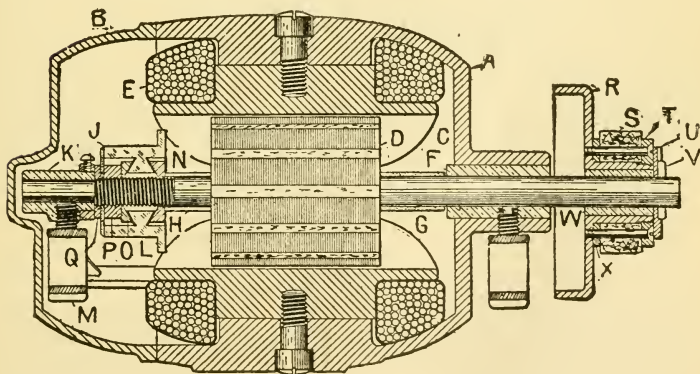

Fig. 59.—Sectional diagram of the Apple igniting dynamo. The parts shown are: A, cast iron body containing the moving parts; B, hinged lid of the body; C, one pole piece of one of the field magnets; F, brass bearing of the armature spindle; G and H, fibre tubes surrounding the spindle; K, brass spider supporting the spindle; L, commutator; M, wick feed oil cup; N, beveled nut supporting the commutator; O, P, Q, supports of the commutator; R, the driving disc; S, lever friction pinion. This machine can generate a direct current at 8 volts at a speed of between 1000 and 1200 revolutions per minute. It is provided with a simple centrifugal governor that automatically interrupts the driving connections when a certain speed has been exceeded.

There are various types of primary cell; those known as **dry cells** are most frequently used. A dry cell is composed of three elements; usually:

1. Zinc;
2. Carbon;
3. Liquid electrolyte.

A zinc cup closed at the bottom and open at the top forms the negative electrode; this is lined with several layers of blotting paper or other absorbing material.

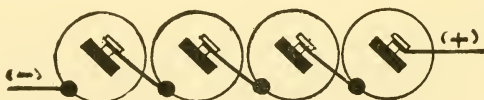

Fig. 60.—Diagram of a series battery connection: four cells are shown connected by this method. If the cell voltage be one and one-half volts, the pressure between the (+) and (-) terminals of the *battery* is equal to the product of the voltage of a single cell multiplied by the number of cells. For four cells it is equal to six volts.

The positive electrode consists of a carbon rod placed in the center of the cup; the space between is filled with carbon—ground coke, and dioxide of manganese mixed with an absorbent material. This filling is moistened with a liquid, generally sal ammoniac.

The top of the cell is closed with pitch to prevent leakage and evaporation. A binding post for holding the wire connections is attached to each electrode, and every cell is placed in a paper box to protect the zincs of adjacent cells from coming into contact with each other when finally connected together to form a battery.

Answers Relating to Primary Batteries, and Battery Connections

Ques. What is the average voltage and amperage of a dry cell when new?

Ans. The average voltage, when new, is one and one-half volts, while the amperage ranges from about twenty-five to fifty amperes, according to size.

Ques. How many volts are required to operate a coil?

Ans. About six, for proper working.



Fig. 61.—Diagram of a multiple or parallel connection. When connected in this manner the voltage of the battery is the same as that of a single cell, but the amperage of the battery is equal to the amperage of a single cell multiplied by the number of cells.

Ques. What are the three methods of connecting cells?

Ans. In series, in parallel, and in series multiple.

Ques. Describe a series connection.

Ans. A series connection consists in joining the positive pole of one cell to the negative pole of the other, as shown in fig. 60.

This adds the voltage of each cell. Thus, connecting in series four cells of one and one-half volts will give a total of six volts.

Ques. What is a parallel connection?

Ans. A mode of connecting cells, as shown in fig. 61, in which the positive terminal of one cell is connected with

the positive terminal of another cell, and the negative terminal of the first cell with the negative terminal of the second cell.

A parallel or multiple connection adds the amperage of each cell; that is, the amperage of the battery will equal the sum of the amperage of each cell. For instance, four cells of twenty-five amperes each would give a total of one hundred amperes when connected in parallel.

Ques. Explain a series multiple connection?

Ans. This consists in connecting two sets of cells in series and then connecting the two sets in parallel, as shown in fig. 62.

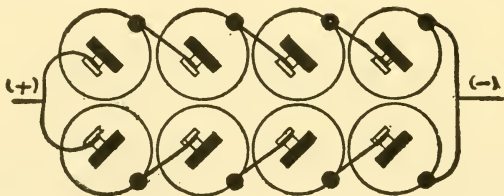

Fig. 62.—Diagram of a series multiple connection. Two sets of cells are connected in series and the two batteries thus formed connected in parallel. The pressure equals the voltage of one cell, multiplied by the number of cells in one battery, and the amperage, that of one cell multiplied by the number of batteries.

In series multiple connections, the voltage of each set of cells or battery must be equal, or the batteries will be weakened, hence, each battery of a series multiple connection should contain the same number of cells. The voltage of a series multiple connection is equal to the voltage of one cell multiplied by the number of cells in one battery and the amperage is equal to the amperage of one cell multiplied by the number of batteries. Figure 63 shows an incorrect method of wiring in series multiple connection. If the circuit be open, the six cells will overpower the four, and cause a current to flow in a direction indicated by the arrows until the pressure of the six cells has dropped to that of the four. This will use up the energy of the six cells, but will not weaken the four cell battery. This action can be corrected by placing a two-way switch in the circuit at the junction of the two negative terminals so that only one battery can be used at a time.

Ques. How should cells be used?

Ans. Two batteries should be provided and used alternately, so that one can recuperate while the other is in use; the stronger should be used in starting.

Ques. What precaution should be taken in renewing cells?

Ans. A greater number should never be put in series than originally came with the machine.

Ques. How many cells are usually necessary?

Ans. With a good coil, four to six cells in **series** will give satisfactory service on most machines, and if four

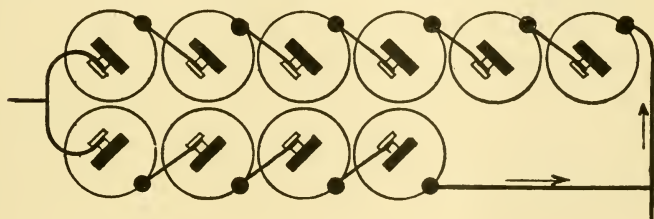

Fig. 63.—Diagram to illustrate incorrect wiring. The voltage of the six cell battery being greater than that of the smaller unit, current will flow from the former through the latter until the pressure of the six cells is equal to that of the four cells.

cells suffice, then a greater number connected in series will last a shorter length of time.

This is because the additional cells increase the voltage beyond that required, and likewise cause more current than is necessary to flow through the coil; this increased flow, of course, shortens the life of the battery.

Ques. How should the cells be connected?

Ans. Heavy copper wire should not be used, because vibration may cause it to break. The terminals should be tightly connected and the spark plugs kept clean.

Ques. What precaution should be taken in washing an automobile?

Ans. Water should not come in contact with the dry cells, because the paper covers forming the insulation will become moist and the current leak across from one cell to another, resulting in running down the battery.

Ques. What are the symptoms of a weak battery?

Ans. When a motor will run at high speed without missing explosions while the car is standing, but will miss under road conditions, it indicates that the battery is weak.

If this condition occur, each cell should be tested separately, because often only one of them has weakened, and it is only necessary to replace the weak ones. This should be done at once, as the weak cell will destroy the strength of the others.

Ques. What trouble is produced by a weak battery?

Ans. It frequently causes difficulty in starting, as a better spark is then required than when the engine is warm.

Ques. How can extra mileage be secured by two run down batteries?

Ans. By connecting them in series multiple.

Ques. What other method?

Ans. As the cells become weak a slight change of vibrator adjustment will prolong their life.

Care should be taken to adjust the coil so that it will use as little current as possible. The vibrator should be screwed down sufficiently to give just enough spark to run the engine; the closer the points, the more the current that will be used. One-third ampere current is the average amount necessary. A half-turn of the adjusting screw on a coil will often increase the current consumed from one-half up to one and one-half amperes, or nearly five times the actual amount necessary.

Ques. Will dry cells deteriorate, except by usage?

Ans. They will deteriorate when not in use, making it necessary to renew them about every sixty days.

It will be economy to do this, as the saving in gasoline will more than offset the additional cost; the reason dry cells deteriorate is because the moisture evaporates.

Freezing, exposure to heat, and vibration which loosens the sealing, causes the evaporation.

Ques. How can weak cells be strengthened?

Ans. They can be strengthened somewhat by removing the paper jacket and punching the metal cups full of small holes, and then placing in a weak solution of sal ammoniac, allowing the cells to absorb all they will take up. This is only to be recommended in cases of emergency when they are hard to get. Each cell when fresh should show from 20 to 25 amperes when tested; the date of manufacture should also be noted, as fresh cells are most efficient.

Ques. What may be said of cells of different voltages or of different makes?

Ans. It is advisable not to put them in the same circuit, for the stronger will discharge into the weakest until all are equal.

Ques. How should dry cells be tested?

Ans. With an ammeter, care being taken to do it quickly, because the ammeter, being of very low resistance, short circuits the cell. When no ammeter is at hand the battery current may be tested by disconnecting the end of one of the terminal wires and snapping it across the binding post of the other terminal; the intensity of the spark produced will indicate the condition of the battery.

Ques. Why is a volt meter not used?

Ans. Because when the cells are not giving out current, the voltage remains practically the same, and a cell that is very weak will show nearly full voltage.

A second chemical means of producing electricity for ignition is the **storage battery**. This consists of two or more secondary cells contained in a carrying case or box, usually of wood or hard rubber.

A secondary cell is made up of a positive and a negative set of lead plates immersed in an electrolyte of dilute sulphuric acid. The proportion of acid to water is about one part acid to three and one-half parts water.

In preparing the electrolyte, acid should always be added to water—**not water to acid**.

In passing an electric current through a cell the plates undergo a chemical change; when this is complete the cell is said to be **charged**. A quantity of electricity has been stored in the cell, hence, the name, **storage battery**.

The cell, after being charged, will deliver a current in a reverse direction, because during the discharge a reverse chemical action takes place which causes the plates to resume their original condition.

When fully charged, the positive plates are coated with peroxide of lead and are brown in color, the negative plates gray.

The positive and negative poles of a secondary cell are plainly marked + and —, or P and N.

Answers Relating to Secondary or Storage Batteries

Ques. What is the voltage of a fully charged cell?

Ans. About two and one-half volts.

Ques. What precaution should be taken in operating a storage cell?

Ans. When current is taken from a cell the voltage drops, and when 1.8 volts is reached the cell must be recharged.

Unless this be done immediately, the cell will deteriorate. The secondary cells forming a storage battery should be connected in series.

Ques. What battery capacity is necessary for ignition service?

Ans. A capacity of 40 ampere hours. A battery of this capacity is composed of three cells having a total pressure of six volts.

Ques. What may be said about charging?

Ans. A storage battery should be charged once every two months whether it be used or not. In charging, a direct current should be used—never an alternating one, care being taken to connect the positive wire to the positive terminal, and the negative wire to the negative terminal. **If connected in the reverse direction, serious injury will result to the battery.**

The simplest method of charging is from an incandescent light circuit, using lamps connected in parallel to reduce the voltage to that of the battery, the current being adjusted by varying the number of lamps in the circuit. The group of lamps is connected in series with the battery to be charged, and the combination connected across the circuit furnishing the current.

If the charging source be a 100-120 volt circuit, and the rate required be 6 amperes, twelve c. p. or six 32 c. p. lamps, in parallel, and the group in series with the battery, will give the desired charging rate, unless special high efficiency lamps be used, when more will be required. In case a lower charging rate, say 2 amperes, be used, then a proportionately fewer number of lamps will be needed, but the length of time required to complete the charge will be correspondingly increased.

Ques. What may be used instead of lamps to regulate the current in charging?

Ans. A rheostat. Its resistance should be such as to produce, when carrying the normal charging current, a drop in volts equal to the difference between the pressure of the charging source and that of the battery to be charged.

Thus, if a battery of three cells giving 6 volts is to be charged from a 110 volt circuit at a 6 ampere rate, the resistance would be, according to Ohm's law:

$$\frac{110-6 \text{ volts}}{6 \text{ amperes}}=17.3 \text{ ohms.}$$

The carrying capacity of the rheostat should be slightly in excess of the current required for charging the battery.

An ammeter with suitable scale should be inserted in the battery circuit to indicate the quantity flowing.

Ques. At what rate, and how long should a battery be charged?

Ans. A battery should be charged at the rate given on the name plate on the case until there is no further rise in its voltage, and each cell has been gassing or bubbling freely for at least five hours, or until there is no further rise in the specific gravity of the electrolyte.

The voltage at the end of the charge may be between 2.4 and 2.7 volts per cell, depending on the temperature and age; the higher voltages are obtained on new batteries with the temperature low; on old batteries at high temperatures the lower voltages are obtained.

It therefore must be understood that in determining the completion of a charge, a fixed or definite voltage is not to be considered, but rather a maximum, as indicated when there is no further rise in the voltage over a period of five hours. It is important that the charge be complete.

Ques. What should be the temperature rise during charge?

Ans. The temperature of the electrolyte, while charging, should not be allowed to rise above 100° Fahr.

Low temperatures do not injure a battery, but have the effect of temporarily reducing its discharge capacity.

Ques. What should be the specific gravity of the electrolyte at the end of a charge?

Ans. It should be 1.3, and should not be altered when the battery is fully charged.

Ques. After altering the gravity, what should be done?

Ans. The battery should be charged for an hour to thoroughly mix the liquid just added.

To add water or electrolyte, or to remove surplus electrolyte, a rubber syringe is employed. A flame should not be brought near the battery during or immediately following the charge.

Ques. What is sulphation?

Ans. The formation of sulphate of lead; it is deposited on the plates in the form of a very hard, grayish coating, and is practically an insulator. In consequence, plates so affected are rendered useless unless the deposit be removed.

Ques. What are the causes of sulphation?

Ans. There are many causes, among which are, too strong, or too hot electrolyte, over discharging, etc. The most common cause of sulphation is excess of discharge. A battery that is discharged to a low point and then allowed to remain unused for a considerable time would be destroyed by sulphation or rendered practically useless.

Ques. What causes local sulphation?

Ans. This is caused by small particles of the active materials, which have become dislodged from the plates, catching in the separators, (used to prevent the plates touching), forming a "bridge" between two plates, and totally discharging them. Sediment, which gradually accumulates in the bottom of the jars, should be removed before it reaches the plates.

Ques. How should a sulphated battery be treated?

Ans. It should be given a long, slow charge at one-quarter the normal charging rate, till the electrolyte shows the proper specific gravity and the voltage has attained its maximum. The terminals and top of the cell should be kept free from acid.

Ques. What may be said of verdigris?

Ans. It forms on the battery terminals and is a poor conductor, hence, it should be removed and the terminals kept bright and clean.

The individual cells of a storage battery should be tested separately in order to determine if there be a weak cell in the circuit, as such a cell reduces the battery output.

There are two methods of producing a current by mechanical means: 1, by the use of a dynamo, and 2, by a magneto.

In any "field," such as that produced around and inside a coil of wire through which a current flows, or between the poles of any magnet either electrical or permanent, there are **invisible lines of force**, which arrange themselves in a definite shape around and between the poles, and if they be cut in any way by moving a wire across them, a current is produced in the wire; this current depends largely upon the number of these lines of force which are cut per second. It makes no difference whether the wire be held stationary and the magnet and its field moved, or whether the wire itself be moved and the field held stationary. The result is the same so far as producing the current is concerned. The utilization of this principle is the basis upon which the mechanical producers of electricity—dynamos and magnetos—are made.

On account of the very general use of multi-cylinder engines for automobiles, a strong impetus has been given to the employment of mechanical generators. When the current is generated by such means, it is not necessary to be economical in its use, as the energy absorbed for ignition by a generator is very small.

Answers Relating to Dynamos and Magnetos

Ques. How does a dynamo differ from a magneto?

Ans. Chiefly in that the dynamo has field magnets of soft iron or mild steel, wound with wire through which circulates the whole, or a portion of the current generated by the machine; a magneto, on the other hand, has field magnets constructed of steel and permanently magnetized.

The circuit diagrams, figs. 57 and 58, illustrate this difference. In the dynamo the field magnets FF are magnetized by means of a small current flowing around a shunt circuit; that is, a certain amount of current is taken from the system and used to magnetize the field. The remainder of the current generated is used in the outside circuit.

Ques. What is the action of the field magnets of a dynamo?

Ans. They increase in strength as the current which passes around them increases. Moreover, as the magnetic strength increases, the voltage of the generated current also becomes stronger.

It is evident, then, that a dynamo is not self-regulating, and if run at too high speed is liable to overheat or even burn out in its effort to furnish a current beyond its capabilities. On account of this faculty of automatically strengthening its own fields, it is necessary that a dynamo be driven at an approximately uniform speed, independent of the speed of the engine, hence, a governor is necessary.

Ques. Describe the drive for a dynamo.

Ans. A dynamo receives motion through a very small wheel in frictional contact with the fly wheel of the engine.

This friction wheel is small enough to run the dynamo at full speed when the engine is turned slowly, as in cranking. When the engine speed increases, the governor acts, and maintains the speed of the dynamo unchanged.

Ques. How is a dynamo generally used?

Ans. In connection with a storage battery, the current for ignition being supplied by the battery, which, in turn, is constantly charged by the dynamo to replace the energy drawn from the battery. An automatic cut out is used, which disconnects the dynamo from the battery when the engine stops. This prevents the battery discharging through the engine.

Ques. How are magnetos classified?

Ans. They may be divided, with respect to the manner in which the current is generated, into two types: 1, those having rotating armatures, and 2, those having stationary armatures with revolving inductors. Magnetos may be further divided with respect to the kind of current generated, into two classes: 1, low tension, and 2, high tension. The latter class may be sub-divided into: 1, true high tension, 2, high tension with self-contained coil, and 3, high tension with separate coil. The last two types are, strictly speaking, not high tension magnetos. Another class comprises the inductor magnetos.

Ques. Describe an inductor magneto.

Ans. In this type the armature is fixed so that it does not revolve, and is located with the sector shaped heads of the core at right angles to the line joining the field poles. This position of the core furnishes the least magnetically conducting path. An annular space between the armature and the field poles is provided for the rotation of an **inductor**. This consists of two diametrically opposite cylindrical

segments of soft iron, supported and carried by a shaft located at the center of the circle described by the segments.

The magnetic condition of the armature core depends entirely upon the position of the inductor. The latter is arranged: 1, to revolve continuously with a gear drive from the engine, or 2, to rotate to and fro through a small arc by link connection to the cam shaft.

Ques. Describe a low tension magneto.

Ans. A low tension magneto has an armature winding, consisting of about 150 to 200 turns of fairly thick wire, covered with a double layer of insulating material. One end of the winding is grounded to the armature core and the other brought to a single insulated terminal. When this terminal is connected to any metal part of the magneto or engine (since the latter is in metallic contact with the base of the magneto), the circuit is complete. The wiring, therefore, is very simple, which is one of the advantages of the system. The "live end" of the armature winding is brought out by means of a metallic rod passing lengthways through the shaft of the armature; a hard rubber bushing is provided as insulation between the shaft and the rod. The live end of the winding is located at one end of the armature shaft, from which the current flows to an insulated terminal by means of a metal contact which is pressed against the revolving rod by a spring.

Ques. How do high tension magnetos differ?

Ans. They may be divided into three classes: the true high tension type in which the induction secondary wiring is wound directly in the armature, and the so-called high tension types in which the secondary coil is contained within the magneto, or in a separate box, usually placed on the dash.

Ques. How is the ignition current delivered to the various cylinders in proper order?

Ans. This is accomplished by a self-contained timing device consisting of as many stationary contacts as there are cylinders, each connected by a cable to its cylinder spark plug. A rotary brush successively delivers current to each of these contacts.

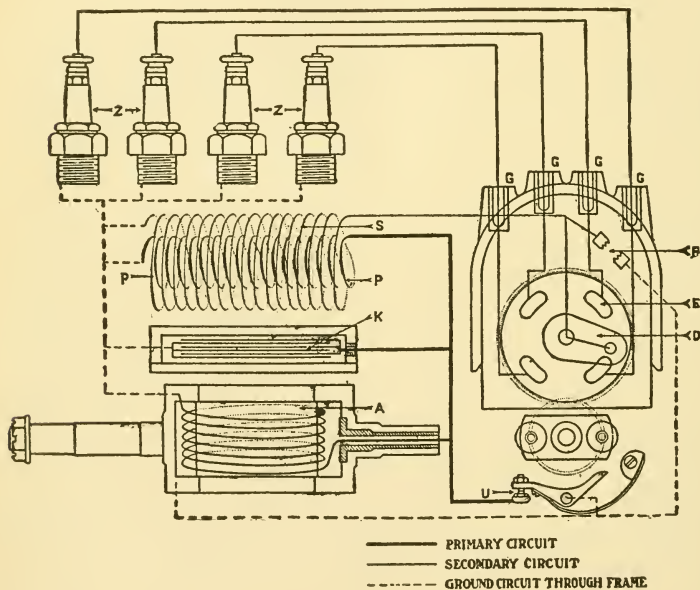

Fig. 64.—Circuit diagram of a magneto with self contained coil. A is the armature winding; P, primary of transformer; S, secondary of transformer; D, distributing brush carrier; E, contact segments; F, safety spark gap; G, terminals to plugs; U, interrupter; Z spark plugs. The principles of operation are described in the text.

Fig. 64 is a circuit diagram of a so called high tension magneto with a self-contained induction coil. A low tension current is generated in the winding A of the armature, which is rotated between two powerful and permanent magnets.

The current flowing from the armature is an alternating one having two points of maximum density in each armature revolution.

In operation, as the current leaves the armature, it is offered two paths: 1, the shorter through the interrupter U to the ground, and 2, the longer through the primary P of the induction coil to the ground. A third path through the condenser K is only apparently available; it is obstructed by the refusal of the condenser to permit the passage of the current, as the condenser will merely absorb a certain amount of current at the proper moment, that is at the instant of the opening of the interrupter. The interrupter being closed the greater part of the time, allows the primary current to avail itself of the short path it offers.

At the instant at which the greatest current intensity exists in the armature, the interrupter is opened mechanically so that the primary current has no choice but must take the path through the primary P of the induction coil. A certain amount of current is at this instant also absorbed by the condenser K. This sudden rush of current into the primary P of the induction coil, induces a high tension current in the secondary winding S of the coil which has sufficient pressure to bridge the air gap of the spark plug.

The sharper the rush of current into the primary winding P, the more easily will the necessary intensity of current for a jump spark be induced in the secondary winding S.

The distribution of the current in proper sequence to the various engine cylinders is accomplished as follows: the high tension current induced in the secondary S of the induction coil is delivered to a distributing brush carrier D that rotates in the magneto at half the speed of the crank shaft of the engine. This brush carrier slides over insulated metal segments E—there being one for each cylinder. Each of these segments E connects with one of the terminal sockets that are connected by cable with the spark plugs as shown. At the instant of interruption of the primary current, the distributing brush is in contact with one of the metal segments E and so completes a current to that spark plug connected with this segment.

Should the circuit between the terminal G and its spark plug be broken, or the resistance of the spark plug be too great to permit a spark to jump, then the current might rise to an intensity sufficient to destroy the induction coil. To prevent this what is known as a safety spark gap is introduced. This will allow the current to rise only to a certain maximum, after which discharges will take place through this gap. In construction the spark discharges over this gap are visible through a small glass window conveniently located.

Ques. What is a synchronous drive?

Ans. For ignition purposes, magnetos are generally constructed to deliver an alternating current, that is, a current consisting of a succession of regularly alternating electrical impulses, varying in intensity from a plus maximum to a negative maximum, and separated by points of zero pressure depending upon the armature position with respect to the field. Hence, it is necessary that the generator, unless geared to run at high speed, should be driven **synchronously**, that is, at a speed in a definite ratio to that of the engine, in order that the periods when a spark is desired shall coincide with the periods when sufficient voltage is being developed, as otherwise the sparking periods might occur with a zero point of electrical generation, and no spark would be produced.

To meet these conditions, the drive must be positive and may consist of either toothed wheel gears or chain and sprocket; the former is more desirable, since, with a chain and sprocket drive, there is sufficient lost motion when the chain is loose enough for smooth running to prevent the accurate timing of the spark.

The friction gear drive or belt and pulley are alike objectionable, from the fact that no slipping or variation is permissible. While some recent forms of high tension magneto are advertised to operate **asynchronously**, that is, not speeded in definite ratio to the engine, the common types are so made that the spark shall occur in the cylinder at precisely the moment the magneto armature is at a certain point in its rotation. If therefore this condition be not strictly observed, the spark will be of defective intensity.

Ques. Name two ignition systems in general use.

Ans. The low tension or **make and break**, and the high tension or **jump spark**.

Ques. What are the characteristic features of these systems?

Ans. The low tension system is electrically simple and mechanically complex, while the high tension system is electrically complicated and mechanically simple.

Answers Relating to Low Tension, or Make and Break Ignition

Ques. Describe a low tension system.

Ans. In this system there is a device known as an igniter, placed in the combustion space of the engine cylinder. This consists of two electrodes, one of which is

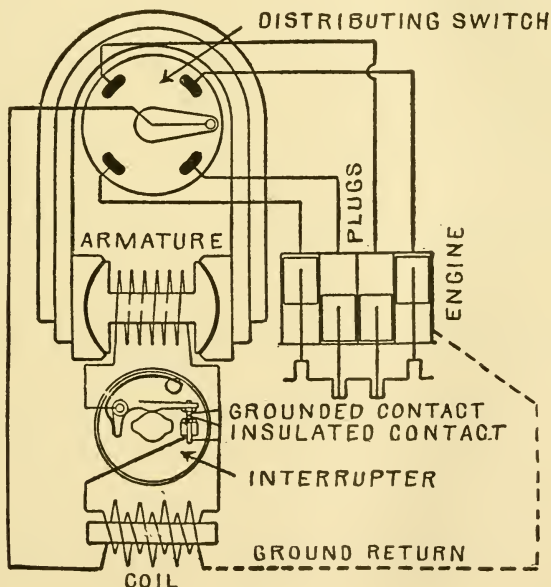

Fig. 65.—Diagram of a low tension magneto showing wiring and connections with engine. The low tension current generated in the armature is transformed into high tension current by means of a secondary coil. The current reaches a maximum twice during each revolution of the armature, hence with a four point distributing switch the armature makes two revolutions to one of the switch. At the points of maximum intensity of the armature current, the primary circuit is broken by the *interrupter*, and the current rapidly falls, inducing a high tension current in the secondary winding of the coil, thus producing the spark.

stationary and the other movable. The stationary electrode is insulated, while the other, having an arm within the cylinder and placed conveniently near, is capable of being moved from the outside so that the arm may come in contact with the stationary electrode and be separated from the latter with great rapidity. The circuit includes a **primary induction coil**. Current may be derived from either a primary battery, storage battery, or low tension magneto.

Ques. How is the spark produced in the low tension system?

Ans. The sudden breaking of the circuit by the quick separation of the electrodes produces an electric arc or **primary spark** caused by the **inductance**—that is, by the “inertia” or tendency of the current to continue flowing after the separation of the contact points.

Ques. What is the object of the primary induction coil?

Ans. To intensify the spark.

When a magneto is used, a coil is not necessary, as the armature winding serves the same purpose. A magneto furnishing either direct or alternating current may be used; the voltage will depend on the armature speed and the strength of the magnets.

Ques. What is used for the contact points of the electrodes?

Ans. Iridium or platinum, as these metals resist the oxidizing effect of electricity and heat better than others.

Ques. What is the action of the current in low tension ignition?

Ans. A considerable interval of time is required for the current to rise to its full value, and the time of separation of the electrodes should not be sooner than the moment when the maximum current strength has been attained. When a magneto is used, the current strength increases with the speed, hence the contact interval can be shorter at high speeds than when a battery is used.

Ques. Describe the action and construction of a primary induction coil.

Ans. When an electric current flows along a coiled conductor, a **counter current** is induced, which opposes any rapid change in the current strength. This principle is employed in low tension ignition to intensify the spark when a battery forms the current source. The device which accomplishes this effect is called a **primary** induction coil because its action is confined to a primary current. It consists of a long iron core wound with a considerable length of low resistance copper wire, the length of the core and the number of turns of the insulated winding determining the efficiency. The current passing through the winding magnetizes the soft iron, and a self-induced current is generated. As soon as the circuit is broken, the magnetic reactance tends to continue the flow of current, despite the break in the circuit, and occasions a spark of great heat and brilliancy. **The spark occurs at the moment of breaking the circuit, not at the moment of making.**

Ques. Name the elements of a low tension circuit.

Ans. The elements which compose a low tension or make and break circuit are as follows: 1, a source of current supply consisting of either a primary battery, accumulator, or low tension magneto, 2, a primary induction coil when a battery is used, 3, an igniter, 4, a switch for breaking the circuit, and an additional switch to alternate between the battery and the magneto when both means of furnishing the current are provided, and 5, connecting wires.

Fig. 66 shows a low tension system of a two cylinder engine having all the above elements. Two sources of current supply are provided: a dry battery and a magneto. One terminal of both the battery and magneto is grounded; the other terminal of the magneto M is connected to the point S of a three-way switch.

The cells comprising the battery J are connected in series and one of the terminals is connected to a primary induction

coil K and thence to the point T of a three-way switch. By moving the arm of this switch to the right or left, current may be had from the battery or magneto, respectively.

A conductor C connects the third point of the switch to the stationary or insulated electrode of each igniter, a single throw switch being placed at each igniter, which allows either or both cylinders to be thrown out of the circuit at will.

The movable electrodes and metal of the engine furnish the ground return to the battery and magneto.

On a multi-cylinder engine it is evident that no other contact can be made at the moment of break in one cylinder since

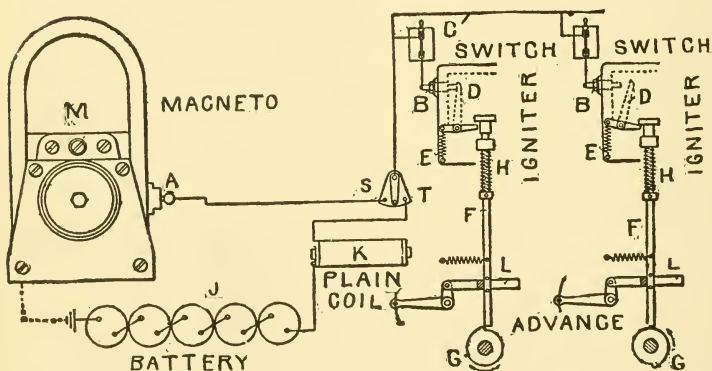

Fig. 66.—A low tension or make and break ignition system. In operation, as the nose of the cam G passes rod F, the latter suddenly drops by the action of spring H. The head of the rod, which has been raised by the cam somewhat above the arm of D, will, in its descent, strike D a blow which abruptly breaks contact between D and B, thus producing a spark. When not acted upon by the head of the rod F, D is held in contact with B by the spring E. The system is explained in detail in the text.

the current would then flow through any other igniter that might be in contact instead of producing a spark at the break.

The operation of the make and break system is as follows: Starting, say, on the battery, the arm of the three-way switch is turned upon point T. The movable electrode D of the first cylinder being in contact with the insulated electrode B by the spring E, the current will flow from the battery J through the coil K, thence through the three-way switch and the single throw switch to the insulated electrode B. The movable electrode D

being in contact with the insulated electrode B, the current returns to the battery through D and the metal of the engine, thus completing the circuit.

As the cam G revolves in the direction indicated by the arrow, the rod F rises, which allows spring E to bring the movable electrode D into contact with the insulated electrode B, thus completing the circuit previously described. When the nose of cam G passes from under the lower end of F, the latter drops with great rapidity by the action of the spring H, and in so doing a shoulder at the upper end of F strikes the external arm of D a blow, causing the contact point of D to be snapped apart from B. This cycle of operations is repeated by the ignition mechanism of each cylinder in rotation.

At the instant the circuit is broken by the separation of the contact points, the counter current induced in the coil K, opposes any rapid change in the current strength, hence, the current continues to flow momentarily after the circuit is broken, resulting in a **primary spark**. The action is the same as though the current possessed the property of "inertia," that is, time and resistance, both are necessary to bring it to a state of rest. This inertia effect is intensified by the action of the induction coil. When a magneto is used, the armature windings serve the same purpose.

The timing of the spark is accomplished by the adjustable guides L, which serve to vary the horizontal position of the lower ends of the rods F and thus vary the instant at which their ends pass the nose of each cam.

Ques. In low tension ignition, what is necessary in order to produce a good spark?

Ans. The "break" or separation of the contact points of the igniter should take place with extreme rapidity, that is, the spring H (fig. 66) should be sufficiently strong to cause the shoulder or rod F, when it falls, to strike the igniter arm a decided blow, thus quickly snapping apart the contact points.

Ques. What is the disadvantage of low tension ignition?

Ans. The mechanical complication necessary to operate the igniter.

Ques. How has this been overcome?

Ans. A method has been devised for operating the electrodes of the igniter by magnetism. This is accomplished

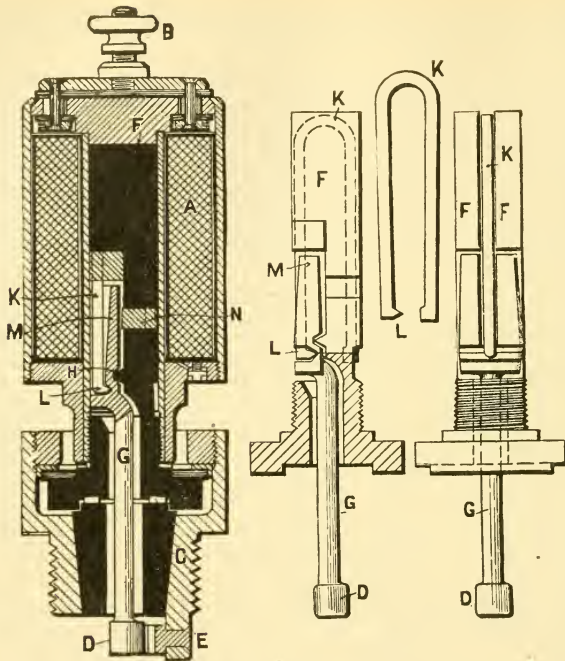

Fig. 67.—The Bosch magnetic spark plug. This consists of a coil A having one end connected to a terminal B and the other to the plug casing C. A spark is produced when a separation takes place between the moving contact D and the stationary contact E. Within the plug is a metal core F and a swinging lever G, which lever pivots on the projection H which is a part of the core F. K shows a portion of a hair pin spring, the end L of which rests in a recess within the lever G, the ordinary tension of the spring tending to hold the lower end of the lever G carrying the contact D against the stationary contact piece E.

by a device known as a **magnetic spark plug**, illustrated in fig. 67. A list of the parts is given under the figure.

The operation of the plug is as follows: When the timing device on the low tension magneto forms a contact for giving a spark to any cylinder, the circuit through the plug is through terminal B, (fig. 67) and the coil A, thence through C and back to the engine.

The completion of this circuit energizes the core F which tends to pull the upper end M of the lever G towards the right, but it is protected from contact with the core by the non-magnetic brass plug N. The pulling of the upper end of the lever G to the right carries the lower end to the left, separating it from the stationary contact E, thereby breaking the circuit. Immediately the circuit is broken, the coil A surrenders its electro-magnetic power, the core F is demagnetized and the end of the hair pin spring L forces the lower end of the lever G to the right, the spring L exerting its pressure beneath the fulcrum H, thus bringing the contacts D and E together.

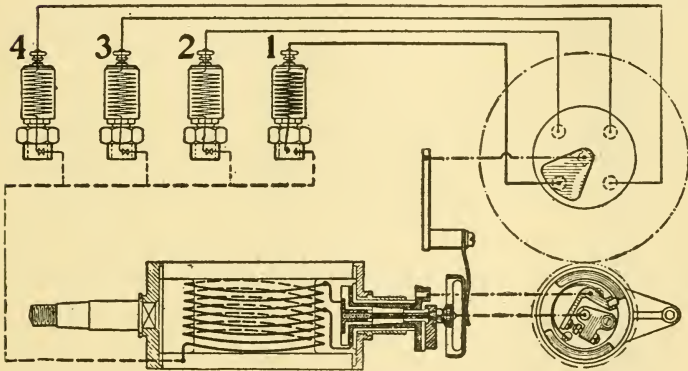
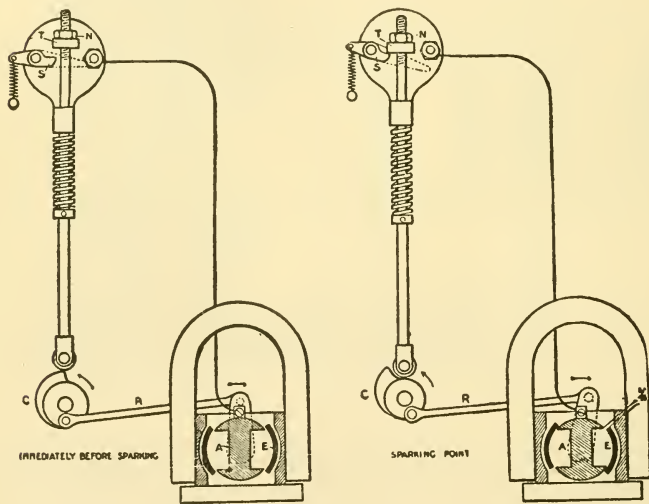

Fig. 68.—Wiring diagram of a low tension system with magnetic spark plugs. A portion of the wiring of the magneto armature is short circuited by the platinum points of the interrupter, and when the circuit is broken, the resulting armature reaction has the effect of raising the armature voltage sufficiently to operate the plugs. The spark is advanced or retarded by rotating the timing lever, in the same manner as with a high tension magneto, and the timing range corresponds to an angle of 50 degrees on the armature shaft. The magneto is switched off in the same manner as a high tension magneto, by making a ground plug connection. This is done by small plug switches with either a single plug or with a number of plugs equal to the number of cylinders, to enable each cylinder to be switched out separately for testing purposes, from the seat while the car is in motion.

At the bottom of the contact piece there is an insulated fixed stem which is magnetically divided near the middle by means of a brass part, so that when the current passes through the coil A, only the portion of the stem above the brass part can be magnetized and, as a result of this magnetization, the upper end M of the interrupter lever G, which directly faces the magnetized part, is attracted, the lower end D simultaneously breaking contact

with the contact piece E, thus interrupting the current and producing a spark. In the normal position of the interrupter lever G, the lower end presses against the contact piece E, being kept in that position by the horseshoe-shaped spring K, which passes right over the top of the stem and lies in the slots in the sides.

The top of the coil is fitted with a terminal screw, to which the current from the magneto is led. Current may also be taken from a primary or secondary battery. In this case a timer in the engine is necessary to distribute the current to the cylinders in proper sequence.



Figs. 69 and 70.—A low tension ignition system with an inductor magneto of the oscillating type. The inductor E is rotated to and fro by means of a link R, one end of which is attached to the inductor crank, and the other to the igniter cam C. Two views are shown: immediately before and after sparking. S is the grounded electrode of the igniter; T an adjustable hammer which is secured in position by a lock nut N.

Ques. Describe the method of using an inductor magneto for ignition.

Ans. In this system of low tension ignition the inductor magneto, having a stationary armature and a rotating inductor, as before described, is arranged to either revolve

continuously or to oscillate through a small arc. An example of the latter type is shown in figs. 69 and 70, which illustrates the Simms-Bosch system.

In the figures, the mechanism is shown in two positions—immediately before and after sparking. The cam which operates the make and break igniter has a link connection to the inductor crank of the magneto, which gives an oscillating motion to the inductor. The connection is such that at the instant of “break” the inductor cuts through the greatest number of magnetic lines.

The cam C, on the half time shaft, makes a contact just before sparking, and immediately breaks it again by permitting the hammer T to fall on the cam S. A spark is produced at the instant of break of contact at N.

The winding of the armature A has one end grounded through the base of the magneto, the current returning through the engine to the point S; the other end of the winding is led through an insulated post to the nut N by which it is connected with a stud brought through the cylinder wall, where a wiper, indicated by dotted outline, normally rests against it by means of a spring.

Answers Relating to High Tension, or “Jump Spark” Ignition

Ques. What device is used to obtain a spark in high tension ignition, and what is its construction?

Ans. A spark plug. This consists of two stationary electrodes, one of which is grounded to the engine cylinder and the other insulated. The points of the electrodes are permanently separated from each other by about $\frac{1}{8}$ of an inch, the space between the points being known as an air gap. This space offers so much resistance to the flow of the electric current that a very high pressure is required to cause the current to burst through the air gap and produce a spark, hence the term “high tension ignition.” Since the spark jumps from one electrode to the other, this method

of igniting the charge is also known as the **jump spark** system. The spark itself is properly described by the prefix, **high tension** or **secondary**.

Ques. In the production of the high tension spark, what two distinct circuits are necessary?

Ans. A low tension or **primary** circuit, and a **high tension** or **secondary** circuit.

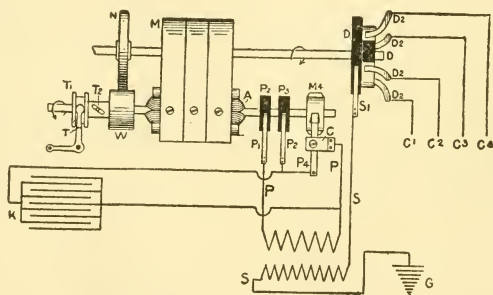

Fig. 71.—Circuit diagram of the Eisemann magneto. A, armature; C, interrupter; C1, C2, C3, C4, high tension leads to cylinders; D, high tension distributor disc; D1, D2, D3, D4, distributor wiper contacts; G, secondary ground on metal of engine; K, condenser; M, permanent magnets; N, gear on distributor shaft; P, P, primary circuit of induction coil; P1, P2, wiper contact on distributor rings of primary circuit; S, S, secondary circuit; T, bell crank for timing; T1, spool in which bell crank works; T2, slotted sleeve on driven shaft; W, gear on driven shaft.

Ques. What names are given to the two circuits in high tension ignition?

Ans. The current which flows through the low tension circuit is called the **primary current**, and that which it induces in the high tension circuit, the **secondary current**.

Ques. How is the high voltage necessary to produce a secondary spark obtained?

Ans. A device known as a **secondary induction coil** is used, which transforms the primary current of low voltage and high amperage into a secondary current of high voltage

and low amperage, that is, the quantity of the current is decreased and its pressure increased.

Ques. What are the general principles upon which high tension or jump spark ignition is based?

Ans. An automatic device is placed in the primary circuit, which closes and opens it at the time a spark is

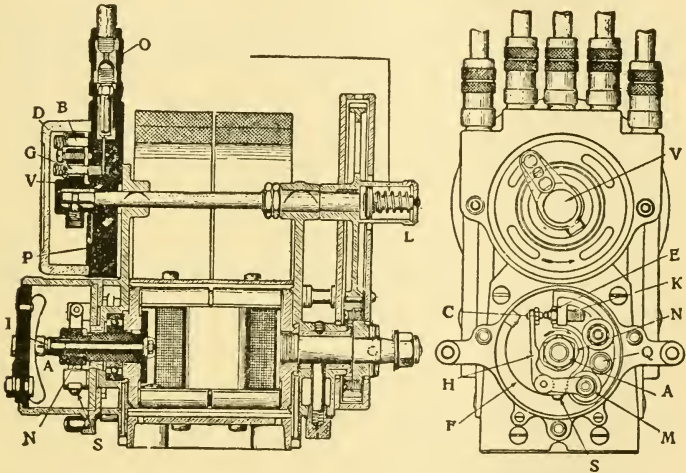

Fig. 72.—The Eisemann magneto with coil in a separate box. Five terminals are shown in the end view; the central one is connected to the coil and the other four to the spark plugs. The two views show the parts as follows: A, cam nut; B, steel contact for high tension distributor; C, platinum contact for make and break lever; D, high tension distributor cover; E, nut for adjustable contact screw; F, spring for make and break lever; G, carbon contact for high tension distributor; H, make and break lever; I, low tension carbon brush; K, adjustable platinum contact screw; L, grease box for large toothed wheel; M, nut; N, cam; O, cable joints; P, distributor plate; Q, metal contact; S, screw for spring for make and break lever; V, high tension distributing switch.

required. When the circuit is closed, the primary current flows through the primary winding of the coil and causes a secondary current to be induced in the secondary winding. A spark plug being included in the secondary circuit, opposes

the flow of the current by the high resistance of its air gap. Since the pressure of the secondary current is sufficient to overcome this resistance, it flows or "jumps" across the gap, and in so doing, intense heat is produced, resulting in a spark.

Ques. Describe another method of working the primary circuit to produce a spark.

Ans. Sometimes the spark is obtained by keeping the primary circuit closed except during the brief interval necessary for the passage of the spark at the plug points. A secondary spark, then, may be produced, by either open or closed circuit working, that is, the primary circuit may be kept either opened or closed during the intervals between sparks.

Ques. What is a contact maker?

Ans. A device which momentarily closes and breaks the circuit at the time of the spark.

Ques. What is a contact breaker?

Ans. A device which keeps the circuit closed except at the time of the spark.

Ques. Where is a contact breaker used to advantage?

Ans. On small engines, run at very high speed, as it allows time for the magnetism or magnetic flux in the core of the coil to attain a density sufficient to produce a good spark.

Ques. What is a timer?

Ans. A device which controls the primary current only.

Ques. What is a distributor?

Ans. A timing device which controls both the primary and secondary currents.

The word distributor is also applied to the revolving switch of a magneto which switches the current to the various cylinders in proper sequence; strictly speaking, however, a distributor is a device, which controls both the primary and secondary currents as previously defined.

Ques. What is an interrupter?

Ans. A contact breaker on a magneto, which breaks the primary circuit at the time a spark is required.

Answers Relating to Secondary Induction Coils

Ques. What is a secondary induction coil?

Ans. A device used to obtain the high voltage necessary to produce a secondary spark; it transforms the primary low tension current into a secondary high tension current.

Ques. What two types of secondary coil?

Ans. The plain or single spark coil, and the vibrator coil.

Ques. Of what does a plain coil consist?

Ans. It consists of: 1, an iron core, 2, a primary winding, and 3, a secondary winding.

The core of the coil consists of a bundle of soft iron wires, about six or seven inches long and in sufficient number to make the diameter of the core about three quarters of an inch. The reason that the bundle of wires is used for the core instead of a solid rod is that the wire core can be more rapidly magnetized and demagnetized. The core is covered with an insulation of paper, vulcanite, or other material, around which is wound the primary coil, which consists of two or three layers of coarse insulated wire.

Sometimes a light insulation is placed over the primary winding, around which is wound the secondary coil consisting of from ten thousand to fifteen thousand turns of very fine wire, insulated by a silk covering. It is usual to place between each layer of the secondary winding a layer of paraffined paper. This insures insulation.

The coil is placed in a neat and substantial box and the terminals of the windings are connected to binding posts placed on the outside.

Ques. Explain the operation of a plain coil.

Ans. When an electric current is passed through the primary winding, it magnetizes the core thus producing a magnetic field in the surrounding space. Any increase or decrease of current in the primary winding induces a current in the secondary winding: **this induced current lasts only during the time of increase or decrease of the primary current.**

Now the pressure of the current induced in the secondary circuit depends upon the ratio between the number of turns of the two windings, upon the sizes of wires used, and also upon the rate of variation of the current strength in the primary circuit. For instance, if the primary winding contain one hundred turns, and the secondary ten thousand turns, the voltage of the secondary circuit will be nearly one hundred times that of the primary.

In a plain coil, the primary current is made and broken once for each spark by a **timing device** on the engine. At every "make" the field of force of each turn in the coil grows rapidly and cuts the neighboring turns, introducing an electromotive force that opposes the increase of the current. On the other hand, at every "break," the primary field rapidly vanishes, the lines again cutting the turns, but in a manner that tends to oppose the decrease of the current. This opposition to any rapid change in the current strength is called **self-induction**. The current which produces the spark occurs at the time of break, and since the strength of this current depends upon the rapidity with which the strength of the primary current falls, a timing device is used, which is so constructed that the break will occur very abruptly.

Ques. How does a vibrator coil differ from a plain coil?

Ans. It gives a series of sparks for each ignition instead of only one.

The view has been held by some that a series of sparks occurring with great rapidity is more effective for ignition than the single spark produced by the plain coil. This led to the development and use of the **vibrator coil**, though opinion differs as to the relative merits of the two systems.

Ques. What is the construction of a vibrator coil?

Ans. A vibrator coil contains, in addition to the two windings of the plain coil, a **magnetic vibrator** and a **condenser**.

Ques. What is the object, and construction of the vibrator?

Ans. To rapidly make and break the primary circuit during the time in which the battery is switched into the circuit by the timer. It consists of a flat steel spring secured at one end with the other free to vibrate. At a point about midway between its ends, contact is made with the point of an adjusting screw, from which it springs away and returns in vibrating. The points of contact of blade and screw are tipped with platinum. One wire of the primary circuit is connected to the blade and the other to the screw, hence, the circuit is made when the blade is in contact with the screw and broken when it springs away.

Ques. What is the office of the condenser?

Ans. A condenser is used to absorb the self-induced current of the primary winding and thus prevent it opposing the rapid fall of the primary current.

Every conductor of electricity forms a condenser, and its capacity for absorbing a charge depends upon the extent of its surface. Hence, a condenser is constructed of conductive material so arranged as to present the greatest surface for a given amount of material. The usual form of condenser for induction coils is composed of a number of layers of tin foil separated by paraffin paper, each alternate layer being connected at the ends.

Fig. 73 is a diagram of a vibrator coil, CC represents the core composed of soft iron wires. PP is the primary winding, and SS the secondary. There is no connection between these windings, and they are carefully insulated. Y is the vibrator, and D the center about which Y vibrates. There is a switch used for opening and closing the primary

circuit; B is a battery of five cells. The point of the adjusting screw A rests against a platinum point R, soldered upon the vibrator.

If the switch W be closed, the electric current generated by the battery B, will flow through the primary winding. This will cause the core CC to become magnetized, and the vibrator Y will at once be drawn towards it. This will break the connection at R. The core, being made of soft iron, immediately upon the

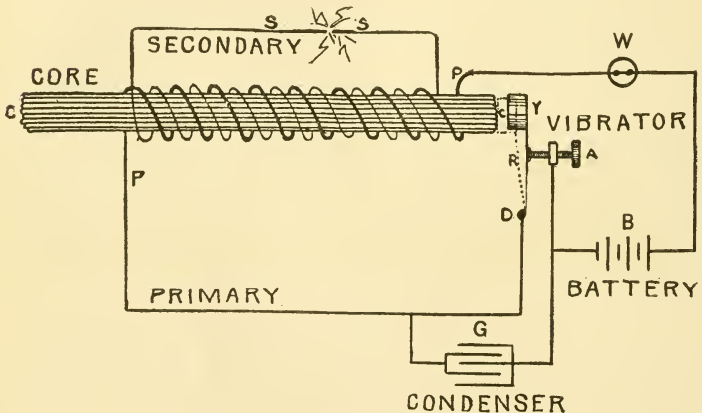

Fig. 73.—Diagram of a vibrator coil. The parts are as follows: A, contact screw; B, battery; C, core; D, vibrator terminal; G, condenser; P, primary winding; S, secondary winding; W, switch; Y, vibrator. When the switch is closed, the following cycle of actions takes place: 1, the primary current flows and magnetizes core, 2, magnetized core attracts the vibrator and breaks primary circuit, 3, the magnetism vanishes, inducing a momentary high tension current in the secondary winding, 4, magnetic attraction of the core having ceased, vibrator spring re-establishes contact, and 5, primary circuit is again completed and the cycle begins anew.

interruption of the current, will again lose its magnetism, and the vibrator will return to its original position. This again closes the circuit, after which the operation of opening and closing it is repeated with great rapidity so long as the switch W remains closed.

Ques. State the cycle of operations of a vibrator coil.

Ans. The several operations comprising the cycle are briefly as follows: 1, a primary current flows and magnetizes

the core, 2, the magnetized core attracts the vibrator which breaks the primary circuit, 3, the core loses its magnetism and the vibrator springs back to its original position, and 4, the vibrator, by returning to its original position, closes the primary circuit and the cycle begins again.

Ques. What is the important requirement in the operation of a vibrator coil?

Ans. The "break" must occur with great rapidity.

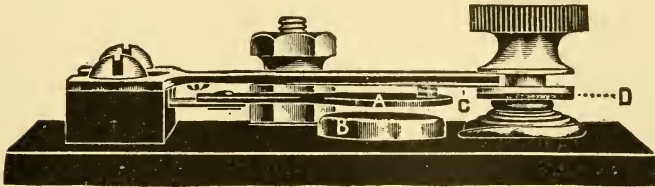

Fig. 74.—A hammer vibrator. When at rest, the upward tension of the spring which carries the armature A, holds the platinum points in contact and causes the upper spring C, to leave the shoulder of adjusting screw D and rest against the heavy brass plate above it. When the iron core, B, attracts the armature, A, the downward tension on the upper spring, C, causes the latter to follow the armature down, holding the platinum points in contact, until the end of the upper spring C, strikes the lower shoulder of the adjusting screw D which gives it a "hammer break." The adjusting screw is held firmly in position by a bronze spiral spring under shoulder D.

In order to render the break as sudden as possible, different expedients have been resorted to, many tending to make the mechanism more complicated, yet having sufficient merit usually to warrant their adoption.

Ques. How is the break sometimes made more abrupt?

Ans. Some vibrators have two moving parts, one of which is attracted by the magnetic core of the coil and moved a certain distance before the break is effected. A vibrator of this type is shown in fig. 74, and described under the illustration.

Ques. Give some general instructions for adjusting a plain vibrator?

Ans. The following adjustments should be made: 1, the contact adjusting screw is first removed entirely, 2, the contact points made flat and cleaned bright, 3, the vibrator spring adjusted so that the hammer or piece of iron on the end of the vibrator spring stands normally about

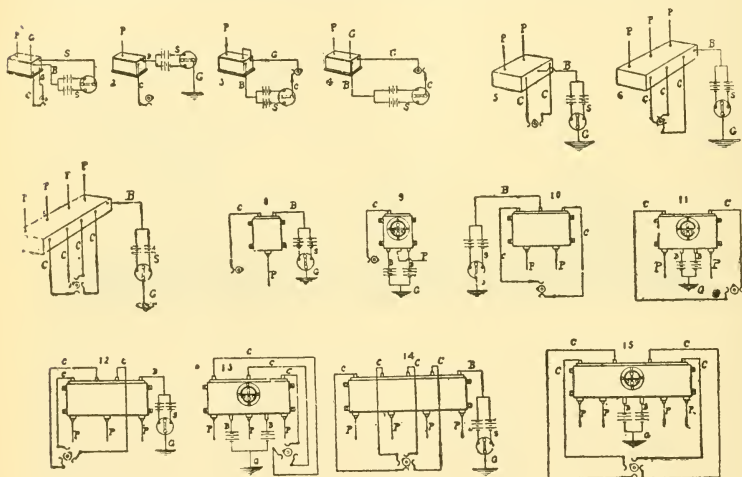

Figs. 75 to 89.—Wiring diagrams showing connections of some standard spark coils. Key: B, to battery; C, to commutator or timer; G, to ground (engine frame); P, to plug; S, to switch; 1, six terminal standard non-vibrator coil; 2, three terminal standard vibrator coil; 3 and 4, four terminal standard vibrator coils; 5, standard double vibrator coil; 6, standard triple vibrator coil; 7, standard quadruple vibrator coil; 8, single dash coil; 9, single dash coil with switch; 10, double dash coil; 11, double dash coil with switch; 12, triple dash coil; 13, triple dash coil with switch; 14, quadruple dash coil; 15, sextuple dash coil.

one-sixteenth of an inch from the end of the coil, 4, the contact screw adjusted until it just touches the platinum contact on the vibrator spring. The engine is now started, and if it should miss, the contact screw should be tightened a trifle, a very little at a time, until the engine will run without missing.

In adjusting the vibrator, the coil ought not to use over one-half ampere of current.

Most spark coils have terminals marked "battery," "ground," etc., and to short circuit the timer for the purpose of testing the vibrator it is only necessary to bridge with a screw driver from the "battery" binding post to the "ground" binding post.

A half turn of the adjusting screw on a coil will often increase the strength of the current four or five times the original amount, hence the necessity of carefully adjusting the vibrator. When the adjustment is not properly made, it causes: 1, short life of the battery, 2, burned contact points, and 3, poor running of the engine.

Ques. On what should the number of cells in an ignition circuit depend?

Ans. They should be proportioned to the design of the coil. If the coil be described by the maker as a 4-volt coil, it should be worked by two cells of a storage battery or four dry cells. The voltage of the latter will be somewhat higher, but since their internal resistance is also greater, the current delivery will be about the same. Most coils are made to operate on from 4 to 6 volts. It is a mistake to use a higher voltage than that for which the coil is designed because it does not improve the spark, and the contact points of the vibrator will be burned more rapidly, moreover, the life of the battery will be shortened.

In order that the spark may occur at the proper instant with respect to the crank position, there must be included in all high tension systems a device called a **timer**, for closing and opening the primary circuit. This causes an induced high tension current to flow at the instant the spark is required.

Answers Relating to Timing Devices

Ques. Describe a timer.

Ans. A timer is a revolving switch which closes and opens the primary circuit. It is operated by the engine, being geared to revolve at one-half the engine speed in the case of a four-cycle engine, and at full engine speed for a two cycle engine.

Ques. What is the construction of a timer?

Ans. All timers consist of a **stationary part** and a revolving part or **rotor**. The former is usually made of a ring of hard rubber, into the inner face of which is let contact segments forming **insulated contacts**; one of these is provided for each cylinder of the engine. The rotor has an arm which makes contact with all the insulated segments during one revolution. A vertical shaft geared to the engine imparts motion, by direct connection to the engine and forms, with the rotor arm, the **ground connection** of the primary circuit. The other wire of the primary circuit for each cylinder is connected to each stationary contact. Hence, during one revolution of the timer arm, the primary circuit is made and broken once for every cylinder in proper sequence.

Ques. How may the spark be advanced or retarded?

Ans. The timer is so arranged that the time of engagement of the stationary contacts with the rotor may be varied with respect to the engine cycle. This is accomplished by constructing the stationary part of the timer

so that it may rotate around the shaft through a small arc. This is controlled by a lever on the steering column.

Ques. What is a brush contact?

Ans. A brush contact consists of a brass brush which bears upon a commutator containing a metal segment with which it makes contact as the commutator revolves.

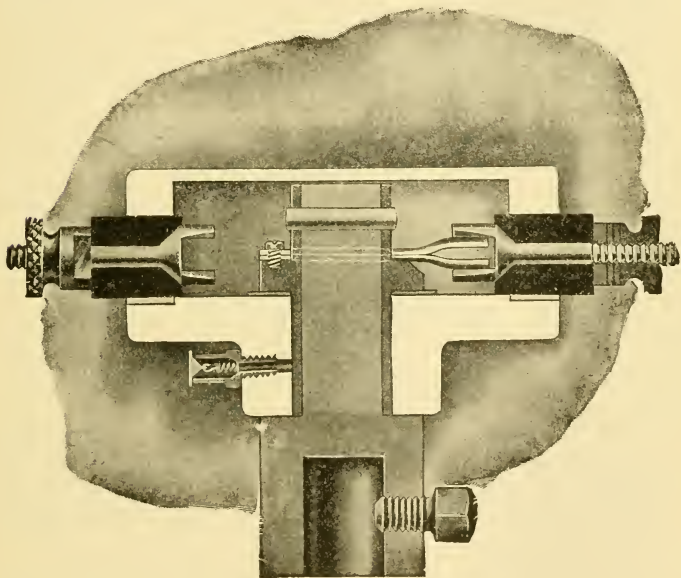

Fig. 90.—Sectional view of the Pittsfield timer. Contact is made by means of phospor bronze springs which revolve on the timer shaft and engage with stationary contacts set in the timer ring and insulated by hard rubber. A set screw fitted to the lower end of the revolving part allows it to be placed on the timer shaft of any engine.

Ques. What is a roller contact?

Ans. A roller contact consists of a roller, attached to the end of an arm which is pivoted to the revolving part of the timer; at the other end is a spring whose tension causes the roller in revolving to bear firmly against the stationary segments.

Ques. What is a sliding contact?

Ans. A sliding contact consists of a spring actuated device on a revolving arm, which rubs against stationary contacts.

Among the special forms of timer is one with two sets of contact segments and contact brushes, forming practically a double timer on a single shaft and in a single casing. The object of this design is to use one set of segments for all ordinary engine speeds and the other for high speeds, and thus to obviate waste of current at low speeds.

It is well known that, in order for the coil vibrator to operate properly at the highest speed of the engine, the timer segments

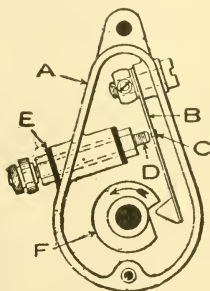

Fig. 91.—A contact maker and mechanical vibrator or *trembler*. The case A is usually attached to the gear box of the engine; B is the blade; C, a platinum contact point; D, an insulated adjusting screw; E, a bushing with insulation, F, the operating cam. As this cam revolves, the weight on the end of blade B drops into the recess on the cam, causing the blade to vibrate and make a number of contacts with D, thus producing a series of sparks when in operation.

must be made to subtend a considerable arc, usually forty-five degrees in a timer for a four cylinder engine. This is a larger arc of contact than is required for normal speed. Suppose, for instance, that it suffices for a speed of 1,400 revolutions per minute, then the length of contact at 700 revolutions, which would probably correspond nearly to the average speed of the engine, would be two times as long as necessary, and there would be a corresponding waste of current. Hence, a variable contact arc is necessary for economy of current.

As constructed, one set of segments gives a contact of 15° and the other 45° . Either set may be brought into use by a switch having two positions, marked "touring" and "speed," the short segments being used for slow speed and the long segments for high speed.

Ques. What is a **mechanical vibrator** or “**trembler**”?

Ans. A form of contact maker which makes, by mechanical means, several contacts in rapid succession for each ignition.

Ques. Describe the construction of a mechanical vibrator?

Ans. One form is shown in fig. 91. The case A is usually connected to the gear box of the engine. A flat steel spring, B, is attached to A. An insulated screw D, is so adjusted that it does not touch the platinum point, C, of the blade B, unless acted upon by the cam. As the cam F, revolves in the direction indicated by the arrow, it comes into contact with a metal nose attached to the end of the blade B. Shortly before the cam has arrived at the position shown in the figure, the pressure due to the action of the spring causes the nose to suddenly drop into the depression in the cam. Its momentum carries it past its normal position, and the point C makes contact with the insulated screw. The metal nose, on account of its weight, will cause the blade B to vibrate, bringing the contact points together several times before the cam again engages the nose.

Ques. How does a plain “contact maker” differ from a mechanical vibrator?

Ans. In the plain form of contact maker, the circuit is closed and opened once only for each revolution of the cam, which in this case has a projection or nose on its circumference instead of a sharp depression. This engages the contact blade and presses it against the insulated screw, thus closing the circuit.

Ques. Describe a contact breaker?

Ans. One form of contact breaker is shown in fig. 92. At the left of the figure is an insulated screw. One end

of a pivoted lever is kept in contact with the screw by a spring as shown, except at the time of the spark. A roller is attached to the other end of the lever, directly below which is a cam. When the nose of the cam engages with the roller, the contact points quickly separate, thus breaking the circuit and producing a spark.

Since the operation of a contact maker keeps the circuit closed for a short interval only, it has been found necessary, with some forms of high speed engine, to use a contact breaker, which keeps

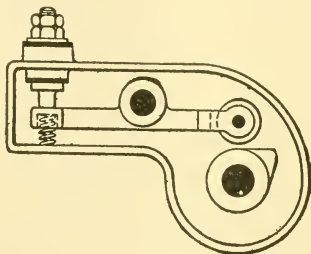

Fig. 92.—A contact breaker. This device keeps the circuit closed at all times except during the brief interval necessary for passage of the spark at the plug points. Used to advantage on engines running at very high speeds, as it allows time for the magnetic flux in the core of the coil to attain a density sufficient to produce a good spark.

the battery and coil in a closed circuit, except during the interval necessary for the passage of the spark. This allows the needed time for the magnetic flux of the core of the magnet to attain a density sufficient to induce a secondary current of the required strength.

When one secondary coil only is used with a multi-cylinder engine, as in synchronous ignition, a device called a distributor is a necessary part of the system. Its use is to direct the discharge of a single coil to the spark plug of each cylinder in rotation. A distributor consists

of a timer for the primary current and a similar device working synchronously, that is, in step with the timer, and which switches the secondary current to the various spark plugs in the proper order of firing.

Ques. Define a distributor?

Ans. A distributor is a combination of two timing devices working in unison with each other; one makes and breaks the primary circuit, while the other makes and breaks the secondary circuit, and in so doing distributes the current to the several cylinders in correct sequence.

Ques. How is the spark controlled?

Ans. The spark is advanced or retarded by the same method employed with a timer.

Ques. Describe the primary element of a distributor.

Ans. This contains as many stationary contacts as there are cylinders, and a revolving arm or **primary rotor**, which, in its revolution, touches each of the stationary contacts, so that the primary circuit is made and broken once for each cylinder during one revolution of the arm. The primary rotor is in metallic contact with the shaft, and forms with it and the engine a ground return for the primary circuit.

Ques. Describe the secondary element.

Ans. The secondary element is above and concentric with the primary part. It has a rotor and the same number of stationary contacts as the primary element; the parts of both elements are arranged symmetrically with each other, and are contained in a compact cylindrical casing. A shaft geared to the engine operates both the primary and secondary rotors.

Fig. 93 is a sectional view of a modern distributor, which differs in some respects from the foregoing description. The

primary element consists of two springs 1, fastened to the shaft 2. The latter is fitted at its lower end with a bushing 3, containing two set screws to secure it to the timer shaft of the engine. It should be noted, that instead of having a stationary contact 4, for each cylinder, only one is provided, but there are additional revolving contacts A, so that the current is made and broken once for each cylinder during one revolution of the rotor. To the shaft, 2, is fitted a hard rubber distributor plate 7, with segment 8, by taper 9. As soon as the springs 1 make contact with the terminal 4, segment 8 comes in contact with one of the terminals 10, inserted in the casing 11. The wiring and operation of the distributor system is later explained under "synchronous ignition."

In some types of distributor, an auxiliary spark gap is included in the design. The secondary rotor is arranged so that it does not actually touch the stationary segments, but terminates very closely to them, the current being required to jump through the short gap intervening between the arm and the segments. This space acts as an **auxiliary spark gap**.

In all high tension ignition systems a **permanent air gap** is placed in the secondary circuit, across which the current must jump to produce a spark. The device by which this permanent air gap is maintained is called a **spark plug**. There are several varieties of these, as follows: 1, primary or make and break plugs, 2, secondary plugs, 3, duplex plugs, and 4, coil plugs.

Answers Relating to Spark Plugs

Ques. What is a primary spark plug?

Ans. A make and break mechanism, operated by a magnet, for producing a primary or low tension spark.

The primary plug has already been described in that section, devoted to the low tension ignition devices.

Ques. What is a secondary spark plug?

Ans. A device which provides a permanent air gap in the secondary circuit for producing a secondary or high tension spark.

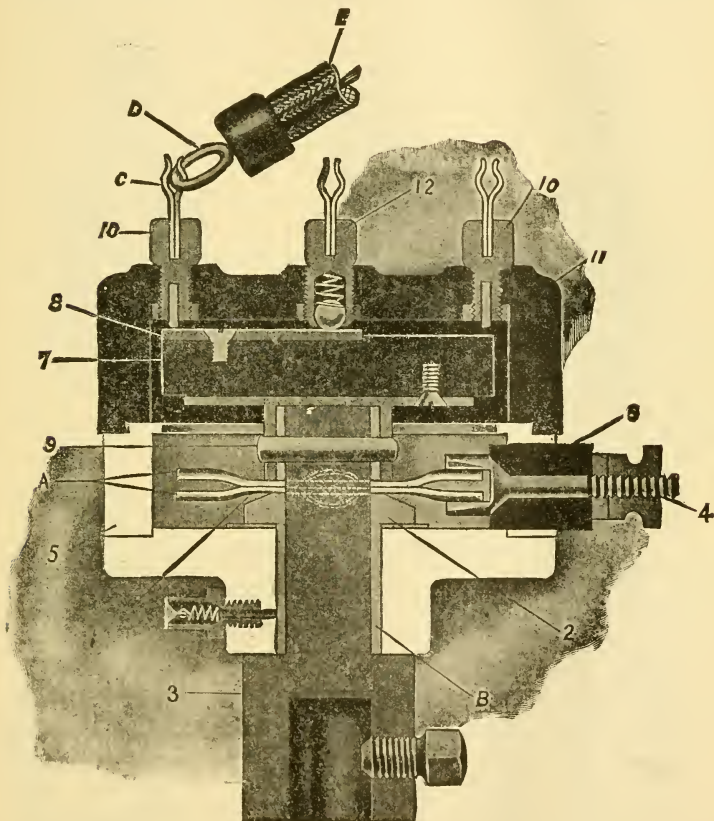
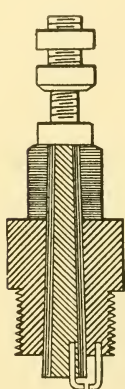

Fig. 93.—Sectional view of the Pittsfield distributor. In this device several revolving contacts are employed instead of one; these consist of a double spring making sliding contact at the portions A. The parts are: 1, contact springs; 2, shaft; 3, bushing; 4, stationary terminal; 5, timer ring; 6, stationary contact insulation; 7, distributor plate; 8, secondary revolving contact segment; 9, taper pin; 10, secondary stationary terminals; 11, casing; 12, secondary terminal for lead to coil; B, slide bearings; C, hook; D, eye; E, secondary cable. The operation of this distributor is described in the text

Ques. What are the essential elements of a secondary spark plug?

Ans. This type of plug is made up of three elements 1, a ground electrode, 2, an insulated electrode, and 3, insulating material, separating the two.



94

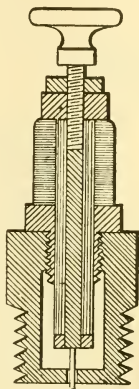

95

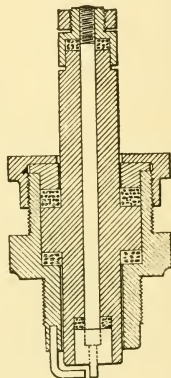

96

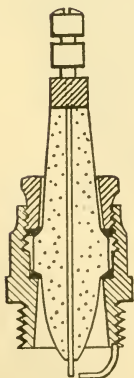

97

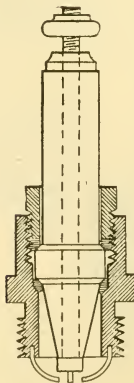

98

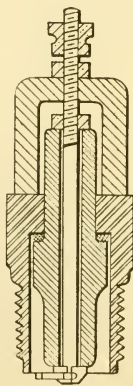

99

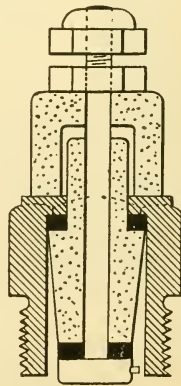

100

Figs. 94 to 100.—Sections of well known spark plugs. The first five have porcelain insulation, the last two mica.

Ques. Describe the ground electrode.

Ans. This is attached to a metal cup which has an external thread so that it may be screwed into the metal of the cylinder, thus forming the ground connection of the secondary circuit.

Ques. Describe the insulated electrode.

Ans. This consists of a thin metal rod located in the center of the plug, and whose end is separated from the ground electrode by about one thirty-second of an inch.

Ques. What is an air gap?

Ans. The space between a break in a circuit, as between the terminals of the two electrodes of a spark plug.

Ques. What materials are suitable for the insulation of a spark plug?

Ans. The insulating material is usually of porcelain or mica, and is cylindrical in shape. It is retained firmly in position by a threaded bushing within the metal cup, which separates the two electrodes.

In many modern spark plugs there is an annular clearance between the insulating material and the inside of the metal cups. In some plugs an additional annular clearance is provided between the insulating material and the insulated electrode. This clearance is provided for the purpose of reducing the danger of short circuits by leaving a larger space between the two electrodes than would ordinarily be filled with soot. According to some designers, it also insures a vortex for the gases, circulating in the primary combustion chamber, under the impulse of the piston strokes, thus expelling a large part of the deposits.

Ques. How may the insulating material fail?

Ans. It may become covered with a coating of soot which, possessing considerable conductivity, affords an easier path for the current than the air gap. It may also become saturated with conducting matter, thus reducing its efficiency and causing a liability of short circuits.

Ques. What is a duplex spark plug?

Ans. A double plug, having both electrodes insulated so that the plug may operate on a metallic circuit.

Ques. What is a coil spark plug?

Ans. An ordinary plug combined with a plain secondary induction coil. The latter is superposed on the plug and contained in a cylindrical casing; the vibrator and condenser are located in a separate box, the object in this case being to minimize the secondary leakage, to have all parts easily accessible, and to simplify the wiring.

A current of very high voltage is required to produce a secondary or jump spark on account of the great resistance due to the air gap and compression pressure which oppose the current flow. The required voltage will depend upon the length of the air gap and the intensity of the pressure inside the cylinder. For ordinary spark plugs in the air the sparking pressure will vary from about 3,000 to 5,000 volts, according to the length of the gap, while to produce a spark in an engine cylinder where the mixture has been compressed to four or five times the atmospheric pressure will require from about 10,000 to 20,000 volts.

Ques. What should be done when a plug fails to work?

Ans. The electrodes and insulating material should be cleaned with fine sandpaper, and the distance between the points adjusted to about one thirty-second of an inch, or about the thickness of a ten cent silver piece. To increase the gap between the points, a knife blade can be used to pry apart the electrodes. If the battery be weak, the gap may be made smaller, say, one sixty-fourth of an inch.

Spark plugs are often damaged by placing a wrench upon the top or lock nut. The plug should be screwed in just tight enough to prevent leakage. An extra spark plug should be carried as an accessory.

Ques. What is a safety air gap?

Ans. An air gap connected in parallel with the secondary circuit. For use on a magneto to secure a discharge of current when the pressure has attained a certain maximum.

A safety air gap is necessary because if the resistance of the spark plug becomes too great to permit a spark to jump, the voltage of the secondary current may rise to an intensity sufficient to destroy the coil.

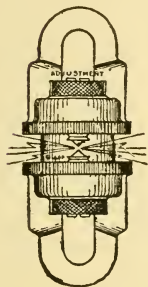

Fig. 101.—An auxiliary air gap. As usually constructed, the auxiliary air gap consists of two adjustable electrodes, set into a short piece of glass tubing.

Ques. What is an auxiliary air gap?

Ans. An air gap placed in the secondary circuit in series with the spark plug. Its object is to prevent any leakage of current in case of defective plug insulation by preventing the flow of the secondary current until the voltage has been raised enough to suddenly break down the resistance of the auxiliary air gap, and also that of the plug. This results in a discharge, through the air gap of the plug, instead of short circuiting over the sooted surfaces of the plug insulation. The construction of an auxiliary air gap is shown in fig. 101.

In any jump spark system two distinct circuits are necessary:

1. A primary or low tension circuit;
2. A secondary or high tension circuit.

The primary circuit is composed of: 1, a source of current supply, 2, a timer, 3, a switch, and 4, the primary winding of an induction coil. These elements are joined in series, the circuit being completed by a ground return.

The secondary circuit includes: 1, the spark plug, and 2, the secondary winding of the coil. One end of the secondary winding is connected to the insulated electrode of the spark plug; the other end is grounded to the metal of the engine; as illustrated in fig. 102, to be described in detail later.

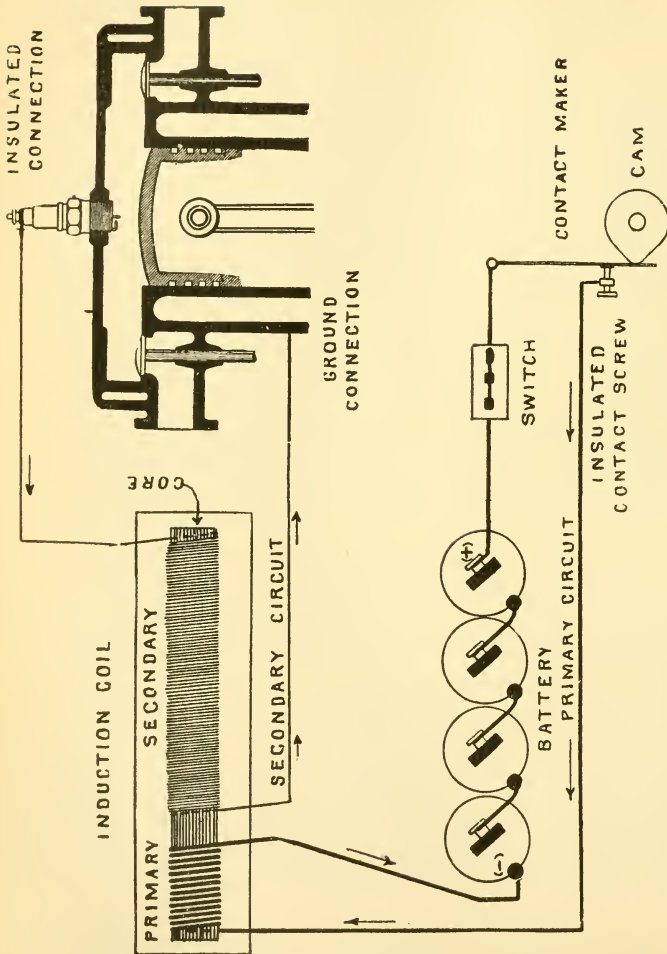

Fig. 102.—Diagram illustrating the principles of high tension or jump spark ignition. The nose of the cam in revolving engages the contact maker which completes the primary circuit and allows the current to flow from the battery through the primary winding of the coil; this magnetizes the core. The primary circuit is now broken by the action of the cam and magnetic changes take place in the coil which induce a momentary high tension current in the secondary circuit. The great pressure of this current forces it across the air gap of the spark plug and as it bridges the gap a spark is produced. The arrows indicate the paths of the currents.

In high tension ignition, there are several systems, among which may be mentioned those using:

1. Plain coils with contact makers or contact breakers;
2. Plain coils with mechanical vibrators;
3. Vibrator coils;
4. Plain coils with master vibrators;
5. Single coils with distributors, as in **synchronous ignition**;
6. High tension magnetos;
7. Coil spark plugs;
8. Special igniting devices.

These systems will now be taken up in the order given, with a brief explanation of each.

Answers Relating to Ignition with Plain Coils, and Contact Makers or Contact Breakers

Ques. Describe a simple high tension ignition system with a plain coil.

Ans. Fig. 102 is a wiring diagram showing the connections. In the figure the primary and secondary windings of a plain coil are shown separated instead of overlapping, so that the circuits may be easily traced. There are two circuits: 1, the primary circuit, which includes the battery, switch, contact maker, and primary winding of the coil, 2, the secondary circuit, which is composed of the secondary winding of the coil, the spark plug and ground return.

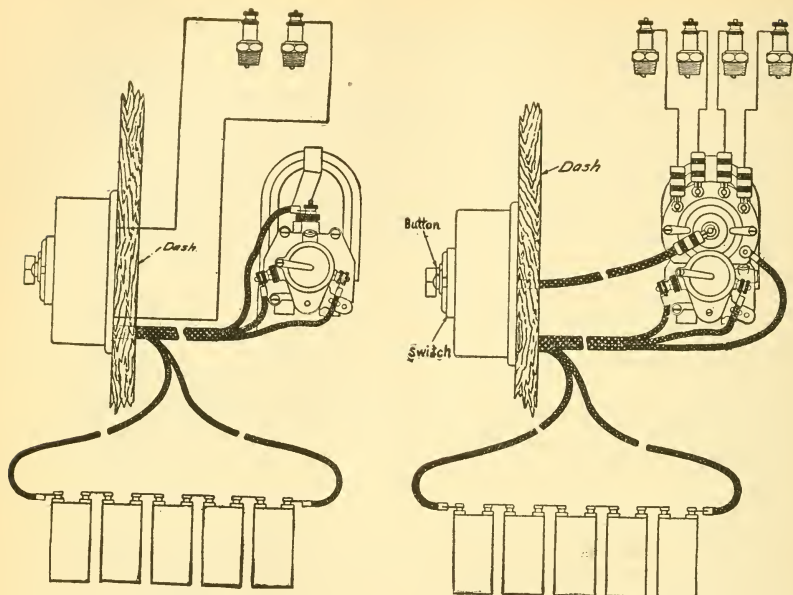

Figs 103 and 104.—Remy wiring diagrams for two and four cylinder engines. This dual ignition system consists of a Remy high tension magneto, battery, coil, and one set of spark plugs. The special coil furnished with the magneto is fitted with a two point switch, used to switch from battery to magneto or vice versa, or disconnect from either to stop the engine. The push button is for starting from the spark with switch turned to the battery side. When the battery is used, the current is simply turned through the coil and distributor of the magneto instead of the magneto current. The speed of the magneto is the same as that of the cam shaft for a two cylinder engine, and twice the cam shaft speed for four cylinders.

Ques. Explain the operation of the system.

Ans. The primary switch is first closed and then the engine cranked. As the piston approaches the upper dead center on the compression stroke, the nose of the contact maker cam engages the blade and brings the contact points together, thus completing the primary circuit. Current now flows from the plus terminal of the battery, through the switch, thence to the metal of the engine and to the blade

of the contact maker. From this point it flows through the insulated screw, lead, and the primary winding of the coil, thence through the return wire to the negative terminal of the battery, thus completing the circuit. This is indicated by the arrows. The action of the cam allows the contact points to touch each other for only a very short time. It should be noted that the primary and secondary wires do not come in contact with each other, both having an insulating covering. The momentary current flowing in the primary winding induces a current of high pressure in the secondary winding, but which flows in a direction **opposite** to that of the primary current as shown by the arrows. This induced current flows from one end of the secondary winding to the metal of the engine and the ground electrode of the spark plug. It then produces a spark by jumping the air gap, thence it returns from the insulated electrode of the plug to the secondary winding of the coil, completing the circuit.

When a contact breaker is used, the primary circuit remains closed except at the time of the spark. This closed circuit working is desirable with some forms of high speed engines in order to allow sufficient time, as before explained, for the magnetic flux in the core of the coil to attain a density sufficient to produce a good spark at the plug points.

The mechanical vibrator system employs a plain coil, and is identical with the one just described with the exception that in place of the make or break timing device, a mechanical vibrator is used, which gives a succession of sparks for firing each charge.

A more refined method of producing a series of sparks for igniting the charge is by the use of vibrator coils. The

magnetic vibrator is a marked improvement on the mechanically operated device, as it vibrates with greater rapidity and is capable of delicate adjustment.

Answers Relating to Ignition with Vibrator Coils

Ques. Describe an ignition system with vibrator coils.

Ans. There is a separate coil for each cylinder, as shown in fig. 105, the several coils are enclosed in a case represented by the dotted rectangle. Each coil has an adjustable contact screw, which is connected by a common wire terminating at the two-way switch; also in each unit, one end of the secondary winding is connected to that end of the primary leading to the vibrator blade. These common connections simplify the external wiring as otherwise there would be four binding posts for each unit. The two-way switch just referred to permits the current supply to be taken from either of two sources, such as a battery and a magneto. Current is supplied by the battery when the switch is in the position shown in the figure. By turning the switch to the right, a current from the magneto will be furnished. In the figure, the primary wiring is shown by heavy lines, and the secondary wiring by fine lines.

Ques. Describe the operation of the system.

Ans. With the battery in the circuit and the timer in the position shown (fig. 105), the operation is as follows: Current flows from the positive terminal of the battery to the switch, thence to the contact screw of coil number two. From here, it flows through the vibrator blade, primary winding of the coil, timer, and the metal of the engine, and returns to the battery. The primary circuit is

alternately opened and closed with great rapidity by the vibrator so long as the rotor of the timer is in contact with the terminal. During this interval a series of high tension currents is induced in the secondary circuit, producing a succession of sparks. These currents flow through the secondary winding in a direction opposite to that of the

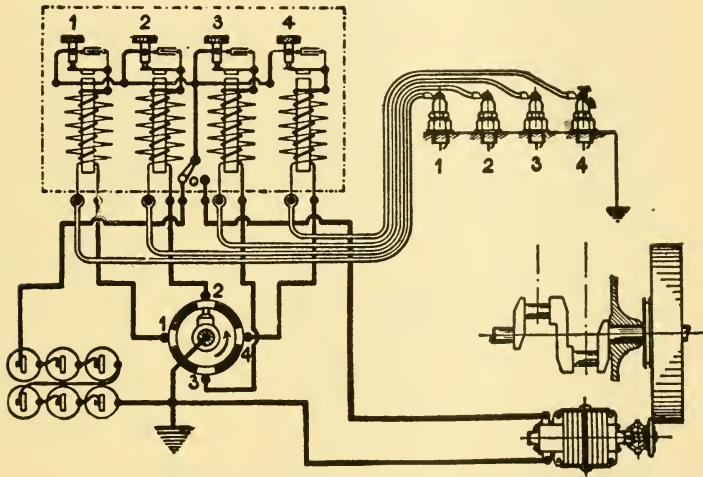

Fig. 105.—Wiring diagram of a dual jump spark system for a four cylinder four cycle engine. A dry battery and low tension magneto form the two sources of current supply. The primary, or low tension circuit, is shown by heavy lines, the secondary or high tension circuit by fine lines, and the leads to spark plugs by the double lines. The dotted rectangle represents the outline of a four unit dash coil.

primary current. At each interruption of the primary current, an induced high tension current flows through the secondary winding, to the spark plug, across the gap producing a spark, and returns through the metal of the engine, timer, and back to the coil. As the rotor of the timer revolves it touches each of the stationary contacts, and in

so doing the above cycle is repeated for each cylinder in the order of firing, as wired.

Ques. By what other method may a multi-unit coil be operated?

Ans. A master vibrator may be used instead of separate vibrators for each coil.

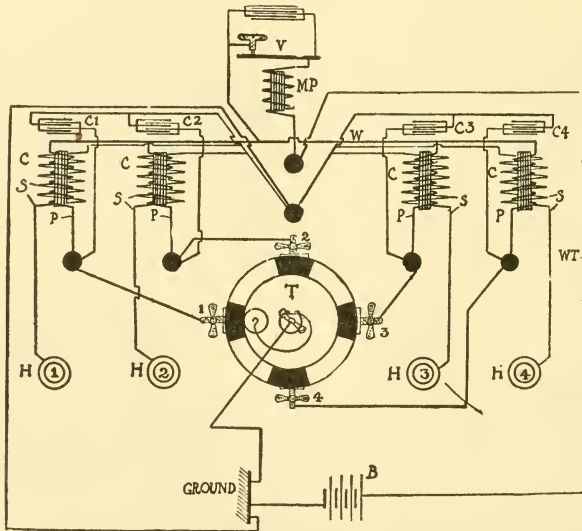

Fig. 106.—Circuit diagram of a master vibrator coil. B, is the battery; C, the unit coils; C1, C2, etc., the condensers; P, the primary windings and S, the secondary windings; H1, H2, etc., the spark plugs; T, the timer; MP the master primary; V, the vibrator; W, the common primary connection; 1, 2, etc., the stationary contacts of the timer.

Ques. What is the advantage of this method?

Ans. There is but one vibrator to keep in adjustment, since this vibrator serves for all the cylinders; whereas, with one for each unit, all have to be kept in adjustment, which involves more attention.

In fig. 106 is shown a master vibrator coil. This has but one vibrator V for the four units of the coil, these being designated respectively: C, C, C, C, and each consisting of a primary winding P and a secondary winding S.

The primary windings are all united in parallel at the top by a wire W, and with the lower ends connecting respectively with the segments of the timer T. The primary winding MP, which operates the vibrator V is in series with this winding, the wire WT connecting from the battery and passing directly through the master primary MP. The four condensers, C1, C2, C3, and C4, are in

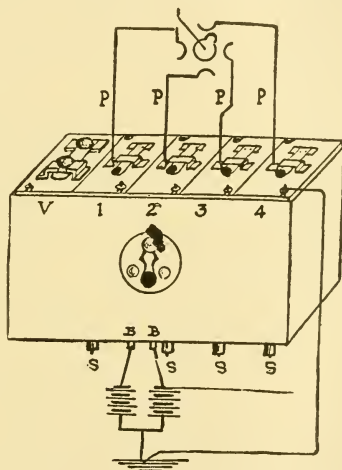

Fig. 107.—The Splitdorf master vibrator coil. As shown in the illustration, the several unit coils are indicated by the figures 1, 2, 3 and 4. A fifth unit V at the left contains the master vibrator. The primary wires P connect with the timer and the secondary wires with the plugs. BB shows the battery connections.

parallel with the primary windings. Each of the secondary windings S connects direct to the spark plugs, designated respectively, H1, H2, H3, and H4.

Fig. 107 illustrates the Splitdorf master vibrator, in which the four coils are designated, 1, 2, 3, and 4, and a fifth unit V in the left of the box contains the master vibrator. The four primary windings connect direct by the wires P with the timer, and the secondaries are connected direct with the plugs. The internal wirings of all of the primaries are in parallel with the electro magnet in the unit V, which operates the master vibrator.

Answers Relating to Synchronous Ignition

Ques. What is synchronous ignition?

Ans. A system of high tension ignition in which a **distributor** and a **single coil** are used for the several cylinders of a multi-cylinder engine.

Ques. Explain the application of the term "synchronous."

Ans. The system is called "synchronous" for the following reason: when a multi-cylinder engine has a coil unit for each cylinder, it requires the adjustment of several vibrators. Now, the time required by the vibrator to act is variable with the adjustment and with slight differences in construction, hence, with several vibrators, perhaps no two will act in the same time. Consequently, though in the ordinary multiple coil system the closing of the primary circuits may occur at exactly corresponding moments for all of the cylinders, the production of the spark of ignition will be more or less "out," owing to the variation in the "lag" of different vibrators. With a distributor and single coil, the lag is the same for all the cylinders, hence the application of the word **synchronous**.

Ques. Describe the synchronous circuits.

Ans. Fig. 108 is a wiring diagram showing the two circuits. The primary circuit includes the battery, switch, primary element of the distributor, and primary element of the coil. The secondary circuit includes the secondary winding of the coil, the secondary element of the distributor, and the spark plugs.

with the stationary segment, the primary circuit is opened and closed with great frequency by the vibrator. This produces a series of induced currents in a reverse direction through the secondary winding of the coil. Each secondary segment of the distributor being wired to one of the spark plugs, the rotor during its revolution brings each plug into the secondary circuit in the order indicated in the diagram. As shown, the secondary rotor is in contact with segment number two, which causes the induced current to flow from the secondary winding, through the distributor, thence to the spark plug, across the gap, through the metal of the engine and back to the coil by the return wire as indicated by the arrows. One end of the secondary winding is usually connected to one end of the primary winding instead of making a separate connection to the metal of the engine. This simplifies the wiring by having one common ground connection.

Ques. What kind of coil is best suited for synchronous ignition?

Ans. One which gives the required work with the least primary current, and which shows freedom from vibrator troubles and the minimum effect on the points after a continuous closed circuit test of at least ten hours.

Ques. Why is this more important with synchronous ignition than when multi-coils are used?

Ans. No coil has been produced which will not, in time, show some pitting of the vibrator points, especially if the direction of the primary current be always the same. A coil worked from a four point distributor will show a given amount of pitting in rather less than a quarter of the time required to produce the same effect if the coil be one of four coils operated by a timer.

It is good judgment to carry a spare coil unit, no matter which system is used, and it should be kept in good condition so that no time need be lost if a change be required.

Ques. How should a battery and coil be connected?

Ans. It is advisable that the vibrator screws be made "positive," so that whatever platinum is carried away by the arc, may be taken from the screw and deposited upon the contact point of the vibrator. The theory is that the screw is cheaper and easier to replace than is the vibrator and that, with this arrangement, the vibrator point builds up rather than wears away, requiring only the smoothing off of the extra metal deposited upon it to keep it in condition.

Answers Relating to Ignition with High Tension Magnetos

Ques. What is the action of current from a magneto upon the vibrator contact points?

Ans. The current from a non-synchronous alternating current magneto produces very little wear on the vibrator points because the current, in the aggregate, is in each direction for one-half the time.

Ques. How may the wear on vibrator points be reduced when a battery is used?

Ans. By periodically changing the direction of the flow of the current. This is done by reversing the wires attached to the battery terminals.

Ques. What are some advantages of ignition with high tension magnetos?

Ans. The wiring is greatly simplified since the coil and condenser are a part of the magneto. Also, hand advance of the spark is not required.

Connections for the Bosch

Dual Ignition.

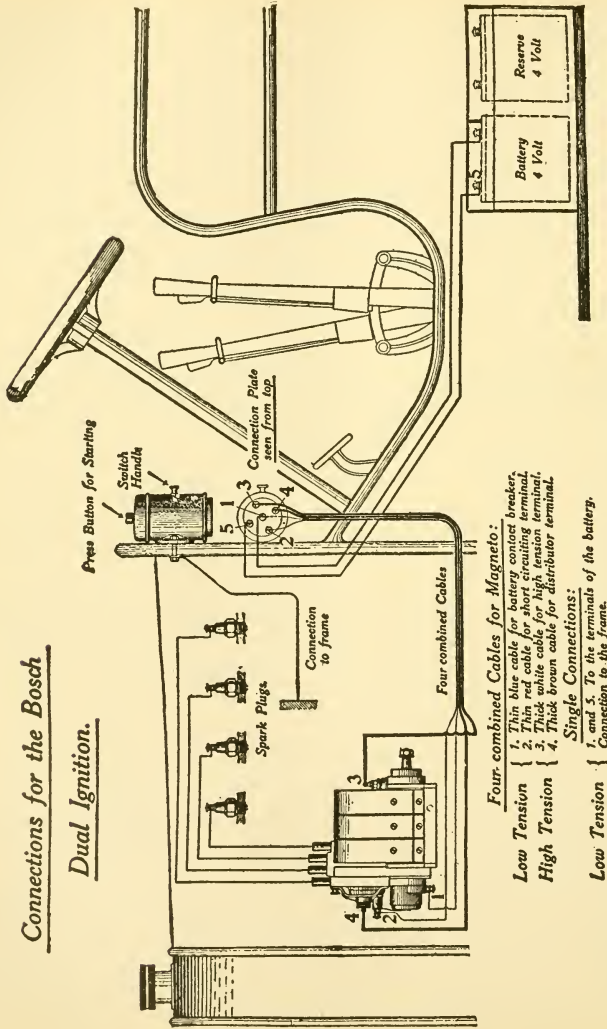

- Four-combined Cables for Magneto:**
- Low Tension { 1. Thin blue cable for battery contact breaker,
 - 2. Thin red cable for battery contact breaker,
 - High Tension { 3. Thick white cable for high tension terminal,
 - 4. Thick brown cable for distributor terminal.
- Single Connections:**
- Low Tension { 1. and 2. To the terminals of the battery.
 - } 3. Connection to the frame.

Fig. 109.—Wiring diagram of the Bosch dual ignition system, using one set of plugs. A special coil is provided with self-contained switch, and a button for bringing a magnetic vibrator into the circuit when desired.

Ques. Why is hand advance not necessary?

Ans. The intensity of a magneto current increases with the speed. Hence, when running slowly, the spark produced in the cylinder will be weak and the charge will be ignited slowly. At high speeds, the strength of the current being greater causes the charge to ignite more rapidly; this charge produces an effect equivalent to advancing the spark.

Ques. What is necessary to start an engine on a magneto?

Ans. The crank must be turned faster than when a battery is used, because the armature must be turned at a certain speed to generate the required current.

Due to the refinement of design, most magnetos will give a spark sufficient for ignition even if the armature be revolved quite slowly.

Ques. Are ordinary spark plugs well adapted to a magneto?

Ans. No, because the current being stronger than that furnished by a battery, the greater heat of the current tends to burn the slender points thought necessary, therefore, with a magneto they must be larger for satisfactory working. The gap of a magneto plug should be less than that of an ordinary plug, because the current, while of greater amperage and heating value, is of less voltage than with a battery system. The gap should not be more than one sixty-fourth of an inch.

Ques. What should receive special attention with magneto ignition?

Ans. It is important that the revolving switch, which distributes the secondary current, and the contact breaker should be kept clean.

The interrupter, which breaks the primary circuit at the time of the spark, should also receive attention and be kept in proper condition.

Ques. Describe an ignition system with a high tension magneto.

Ans. In fig. 109, the magneto is shown at the left. It is of the true high tension type, but differs from the standard rotary armature type in two respects: 1, the high tension connections are slightly altered, and 2, an additional contact breaker is provided for the battery so that

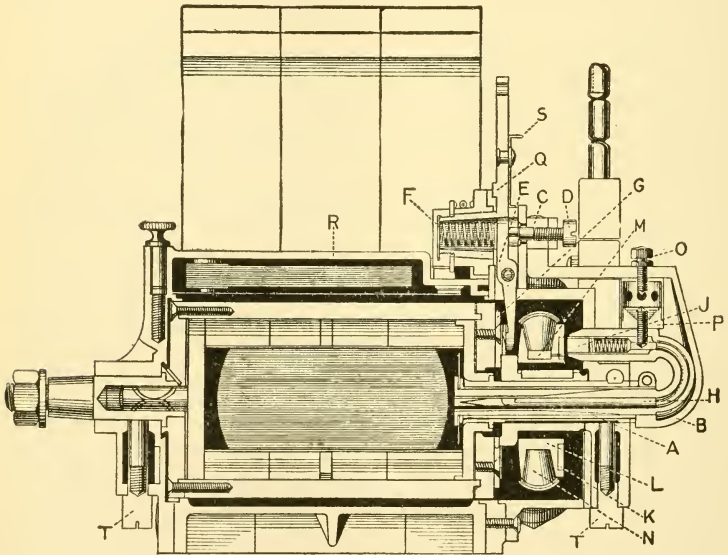

Fig. 110.—Section through the Simms-Bosch high tension magneto. A, armature shaft; B, curved arm carrying high tension lead; C, lug supporting screw, D, adjusting contact breaker, E, against spring, F; G, revolving sleeve carrying face cams; H, high tension lead wire; J, carbon brush of distributor; K, insulated ring; L, rotating drum of distributor; M and N, distributor brushes; O and P, safety spark gap; Q, swiveled lever for retarding or advancing the spark time; R, condenser; T, T, spring pushed wick oilers for armature spindle.

the magneto will serve also as a timer, while the secondary timing device on the magneto is used for both the magneto and the battery current. All other details are similar to those of ordinary machines.

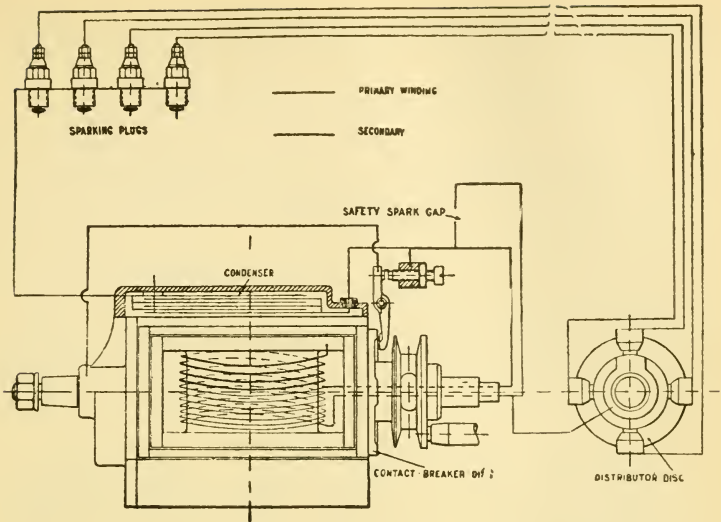

Fig. 111.—Circuit diagram showing the Sinim-Bosch high tension magneto wired up to spark a four cylinder engine. The secondary current is led from the armature winding by a wire, encased in a tube, which emerges from the spindle of the armature. Thence, through a carbon brush bearing upon a flat brass ring, on the front of the secondary distributor, it passes to the contact segment; being conveyed to each spark plug in turn through the four brushes of the secondary distributor.

Ques. How can the battery be used in place of the magneto?

Ans. For battery ignition a special dash coil is provided, having a self-contained switch and button for bringing a magneto vibrator into the circuit when desired. The vibrator is only brought into operation for starting the engine from the seat. After starting, the vibrator is cut out and the interruption of the current effected by mechanical means, hence, there is no lag in the operation of the interrupter, as with magnetic vibrators. If there be any mixture in the cylinder, the engine can be started from the seat by pressing the button. The switch handle, which projects through a slot in the casing of the coil, locks in

three positions by a spring, the positions being designated respectively, "Magneto," "Off," and "Battery." The wiring connections are as shown in the illustration.

Answers Relating to Ignition with Coil Spark Plugs

Ques. Describe a coil spark plug.

Ans. This type of plug consists of a combined spark plug and induction coil, the latter being encased in mica

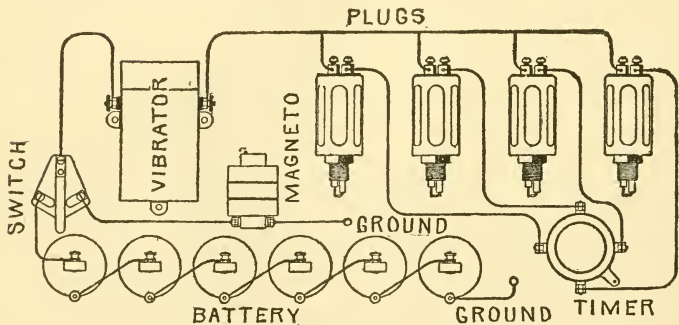

Fig. 112.—Wiring diagram of a coil spark plug system. There is no ground connection for the secondary terminals, as these are connected inside directly to the electrodes of the spark plug, both electrodes being insulated. A condenser and vibrator are placed in the box shown at the left of the figure. In this system only the low tension wiring of the primary circuit is exposed.

and hermetically sealed. Outside this is a metal cover that protects and supports the whole. The ends of the primary winding are connected to binding posts on top of the casing. The two electrodes of the plug form the terminals of the secondary winding. A master vibrator and a condenser are contained in a separate box.

Fig. 112 is a wiring diagram, showing the connections for a four cylinder engine fitted with coil spark plugs. The current supply may be from either battery or magneto, as illustrated. It should be noted that in wiring, only the primary circuit is exposed. The plug shown in the illustration has no ground connection of the secondary terminals, that is, both electrodes are insulated. The connections of the circuit may be easily understood from the figure.

A modification of the plug just described is one having a ground return, as shown in fig. 113, for both the primary and secondary currents. In other respects, the wiring does not differ.

Ques. What advantage is claimed for the coil plug system?

Ans. The loss by secondary leakage due to imperfect insulation or **Hertz wave** is avoided. Accessibility also is secured by the separation of the coil and the condenser.

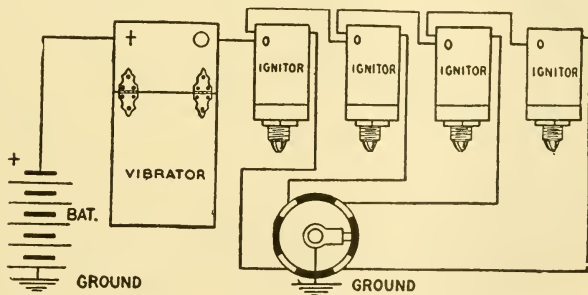

Fig. 113.—The Perfix ignition system. The ignitors consist of coil spark plugs, each having one electrode grounded. A box shown to the left contains the vibrator and condenser. In this method of ignition the primary wiring only is exposed.

Ques. What is dual ignition?

Ans. Two modes of ignition having **one or more parts in common**.

Ques. What is double ignition?

Ans. Two independent means of ignition having **no parts in common**, thus if anything should happen to one system the other may be brought into use.

that the duration of the contact period is just sufficient for the proper building up of the magnetic field about the coil windings, before the occurrence of the break. Because of this, it is usual to so set the adjustable point of the breaker that the contact duration is the minimum with which a proper igniting spark can be procured.

Fomerly dry cells gave satisfaction with one or two cylinder engines, but with the introduction of the four and six cylinder units it was found that the increased current consumption caused the rapid exhaustion of the battery. On this account the storage cell of greater first cost but longer life was substituted. Since single break igniting devices have been in use it has been demonstrated that, with proper treatment, the dry cell battery can be made to give as good service as can any other type of battery.

Ignition Troubles

To successfully cope with ignition troubles there are two requisites: 1, a thorough knowledge of the system used, and 2, a well ordered course of procedure in looking for the cause of the trouble.

In many ignition systems the chief difficulty encountered in the location of defects arises from the fact that faults in different portions of the circuit sometimes makes themselves manifest by the same symptoms. If each defect had its individual symptom, locating the trouble would be comparatively easy, but, as it is, it is sometimes quite difficult to find the defective parts. In general, the following method should be adopted to locate ignition troubles:

1. The source of current supply should be examined; if a battery, each cell should be tested separately, and any one found to be weak, removed. If a magneto be used,

it should be disconnected, and the armature turned by hand; in case the field magnets have not lost their proper strength, the armature should turn perceptibly hard during certain portions of each revolution.

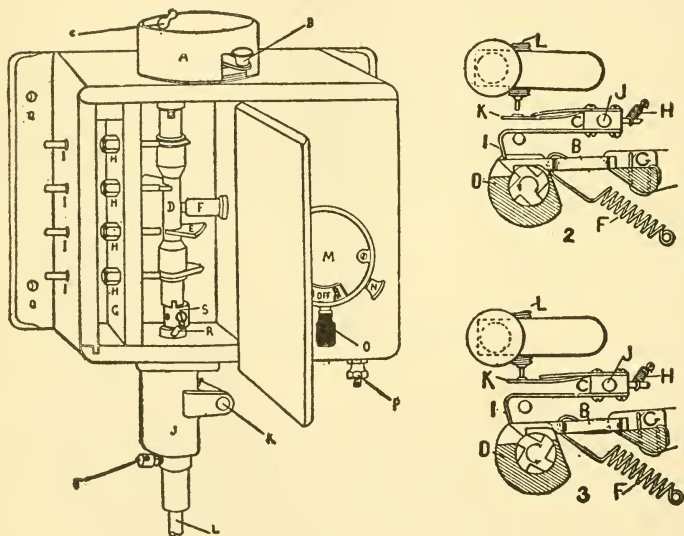

Figs. 115 to 117.—1, the Atwater Kent spark generator, 2 and 3, sectional views showing two positions of the contact maker. This device is designed especially to secure economy in the use of current and is adapted to operate with a dry battery. The generator comprises the following elements: 1, a plain secondary coil, 2, condenser, 3, contact maker, 4, secondary distributor, 5, spark advancing device, 6, starting button, and 7, individual cut-outs for testing the cylinders separately.

2. The primary circuit should be examined for breaks; all connections made bright and secured firmly by the binding screws, and the timer contacts cleaned.

3. The spark plug points should be cleaned and the air gap made the proper length—about one thirty-second of an inch.

4. The vibrator contacts should be made flat and clean, and the vibrator properly adjusted.

Testing the Spark Plug.—The spark plug should be unscrewed and placed on the cylinder without disconnecting the wire to the insulated electrode; the body of the plug only should touch the metal of the cylinder. On cranking the engine the spark should be "fat" if everything be in good condition; if a weak spark be produced it may be due to either a loose terminal, run down bat-

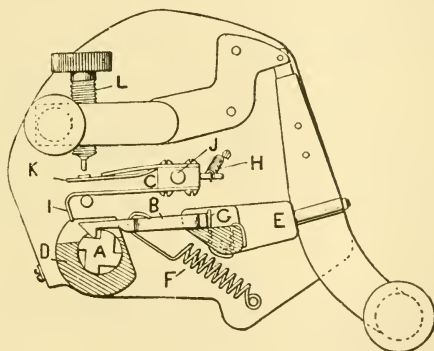

Fig. 118.—Contact maker of Atwater Kent spark generator. The moving parts are the shaft A, the snapper B, and the pivoted contact arm C. The shaft carries four (or six for a six cylinder engine) milled notches forming a ratchet which engages the claw at the end of the snapper B. The operation of the device is explained in the text.

tery, or badly adjusted vibrator. When no spark can be obtained the entire system must be examined and tested, beginning at the battery.

Plug Testing in Multi-Cylinder Engines.—All nuts are removed from the plug, leaving the high tension wires in place. After starting the engine, all wires are grounded except one, thus running the engine on one cylinder. In case there be no misfiring after testing at various engine speeds, it can be taken for granted that the plug is sound. The remaining plugs are tested in the same manner. When a multi-unit coil is used, a faulty plug may be

located by holding down all the vibrator blades but one, so that only one spark plug operates. Running each cylinder separately by this means, it can easily be ascertained which plug is defective. Some coils are provided with little knobs for cutting out cylinders in the manner just described.

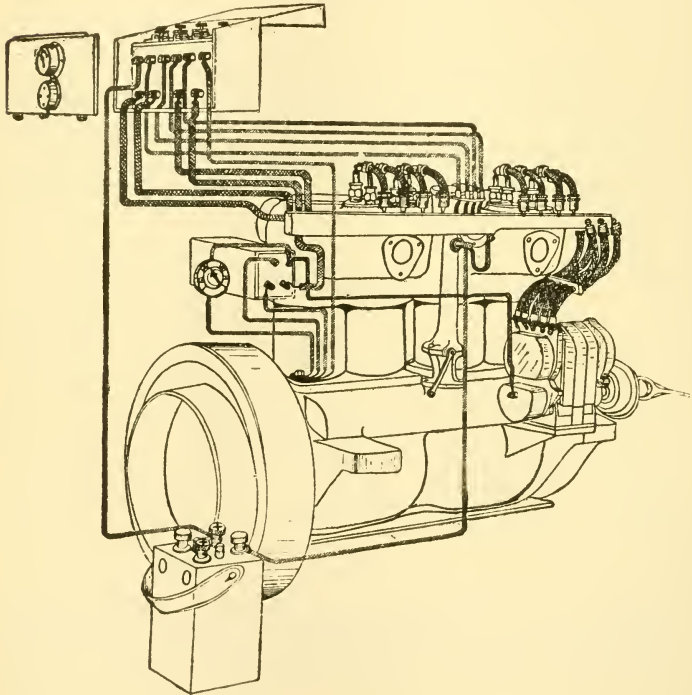

Fig. 119.—A double ignition system with two sets of spark plugs as fitted on Peerless cars. The current, which is furnished by an Eisemann low tension magneto, passes through an induction coil on the dash, giving a high tension current at the spark plugs. In addition to the magneto and entirely independent is a battery system of ignition, operating the second set of spark plugs. The large number of connections necessary is somewhat simplified by the use of a rubber wire bar as shown.

Complete Break in the Wiring.—The engine is placed upon the sparking point, the primary switch closed, and the two terminals of the suspected wire touched with a test wire. A flow of current indicated a break.

Partial Break in the Wiring.—A partial break, or one held together by the insulation, may sometimes be located by bending the wire sharply at successive points along its length, the engine being at the sparking point and the switch closed as before.

Primary Short Circuits.—The primary wires should be disconnected from the coil, leaving the ends out of contact with anything. There is a short circuit if on touching the switch points momentarily a spark appear. A short circuit may sometimes be overcome by clearing all wires of contact with metallic bodies, and pulling each wire away from the others which were formerly in contact with it.

Secondary Short Circuits.—The secondary lead from the spark plug should be disconnected. Under this condition the high tension current may sometimes be heard or seen discharging from the secondary wire to some metallic portion of the car. Water in contact with the secondary wire will sometimes cause a short circuit unless the insulation be of the best quality.

The Primary Switch.—This portion of the primary circuit sometimes causes trouble by making poor contact. This is generally due to the deterioration of the spring portion of the metal, which gradually loses its resiliency. Snap switches sometimes fail through the weakening of the springs which hold them in the "on" or "off" position. The contacts of a switch should be kept in good condition.

Primary Connections.—All binding posts and their connections should be clean and bright. The wires should be firmly secured to the binding posts, as a loose connection in the primary circuit is often the cause of irregular misfiring or the stopping of the engine.

Vibration.—Since the wires are subject to constant vibration, a number of strands of fine wire is better than a single heavy wire, as the latter is more liable to be broken. In securing the wire to a binding post, care should be taken that all the strands are bound.

Timers.—These may give trouble by: 1, presence of dirt, 2, loose contacts, or 3, division of the spark; this latter effect is sometimes caused by metallic particles wearing off the revolving part forming a path so that the spark passes from the revolving part to more than one contact segment.

Coils.—The part of a coil which requires most frequent attention is the vibrator. The contact points are subject to deterioration

on account of the small spark always present between the points when the coil is in operation. In time, the points become corroded and burned, and therefore require to be resurfaced by smoothing with a fine file. A faulty connection to the condenser is at once shown by large sparks at the vibrator points. Any repairs to a coil, aside from the vibrator, should be done by an expert, as the construction is very delicate.

Igniters.—In make and break ignition, a failure to get a spark, especially with a weak battery, is frequently due to the tappet spring. This spring must be quite stiff so as to cause the break to take place with considerable rapidity; **the more rapid the break the better is the quality of the spark.** The contact points of the igniter electrodes are subject to corrosion and wear. When they become pitted the contact surfaces should be filed smooth.

Spark Plugs.—Repeated failure to start when the coil vibrator operates, indicates a faulty spark plug. A rich gasoline mixture often leaves a carbon deposit, and being a partial conductor short circuits the plug. The porcelain insulation, on account of its brittleness, may crack inside the sleeve, allowing a spark to pass there instead of at the gap. Mica insulation sometimes becomes saturated with oil, causing the layers to separate, permitting a short circuit.

Engine Misfires and Finally Stops.—This may be due to exhaustion of the battery, and is indicated by a weak spark and very faint vibrator action.

Engine Suddenly Stops.—This is generally caused by a broken wire or loose switch which does not stay closed. In the case of a single cylinder, the broken wire may be either in the primary or secondary circuit, if a multi-cylinder engine, the break is in the primary circuit.

Engine does not Start.—Usually caused by: 1, primary switch not closed, 2, battery weak or exhausted, 3, entire or partial break in wire, 4, loose terminal, 5, moisture on spark plug, 6, fouled plug, 7, spark too far retarded or advanced, or 8, too slow cranking with magneto ignition.

Engine Runs Fitfully.—Frequently results from a partial break in the wiring, especially in the primary circuit.

Pre-ignition.—Caused by: 1, some small particle in the cylinder becoming heated to incandescence, 2, the electrodes of the spark plug becoming red hot, or 3, intermittent short circuit in the primary.

Engine Runs With Switch Open.—Usually caused by: 1, overheated engine or plug points, 2, primary short circuit, or 3, defective switch, 4, an incandescent particle inside the cylinder.

Engine Misfires.—This may be caused by: 1, weak battery, 2, partial break in conductor, 3, loose or disconnected terminal, 4, intermittent short circuit in the secondary, 5, faulty action of either timer or vibrator contacts, 6, bent vibrator blade, 7, faulty spark plug, or 8, air gap too large.

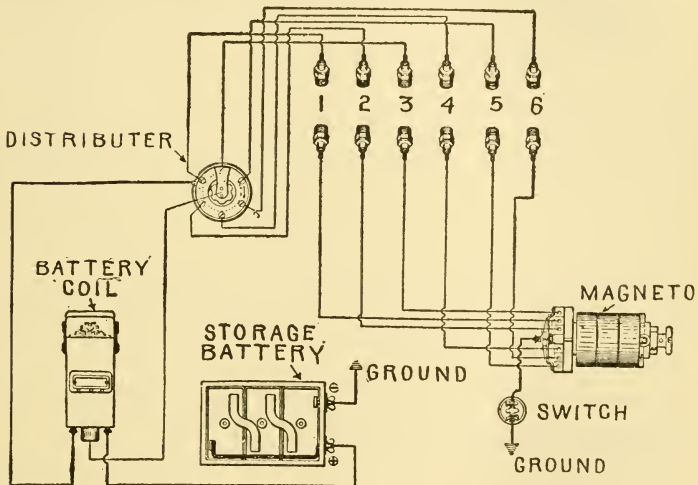

Fig. 120.—Wiring diagram for a six cylinder car, illustrating a double ignition system with two sets of spark plugs. One system consists of a high tension magneto with connections from its distributing terminals to one set of spark plugs; a second system is composed of a battery, vibrating coil, distributor and connections with the second set of plugs.

Knocking of Engine.—Too much advance of the spark sometimes produces this effect.

Knocking in the Cylinder.—The form of unusual noise commonly described as "knocking" consists of a regular and continuous tapping in the cylinder, which is so unlike any sound usual and normal to operation that, once heard, it cannot be

mistaken. Too much advance of the spark sometimes produces this result. As mentioned by numerous authorities, the placing of the spark plug in the exact center of the combustion space occasions a peculiarly sharp knock, which may be stopped by advancing or retarding the spark from the one point of trouble. This explanation of the trouble is questioned by others, and is probably over rated.

Loss of Power Without Misfires.—This may be due to badly adjusted coil contacts, poor spark, or incorrect timing.

Explosions in the Muffler.—These are usually caused by mis firing, partially charged storage battery, or by one cylinder not working.

“TIMING” AND BALANCING

The system or process by means of which the moment of ignition and the opening and closing of the valves is regulated in an internal combustion engine is called timing.

The timing of the valves is an expression analogous to “valve setting” in regard to a steam engine.

Balancing involves some mechanical means for rendering all movements perfectly even and for neutralizing thrusts and vibration; considerable ingenuity has been exercised in the effort to achieve a perfect solution.

Answers Relating to Balancing

Ques. How is a single cylinder engine balanced?

Ans. By fastening counterweights on the opposite side of the crank.

Ques. How is a double cylinder engine balanced?

Ans. In a two cylinder engine the cranks are often placed opposite each other. This mechanically balances the engine, but the explosions will take place at irregular intervals and thus cause the engine to vibrate. In some engines both cranks are set the same way, and counterweights are attached as in a single cylinder engine.

The explosions in such engines take place at regular intervals, but in practice it is found that such engines vibrate more than the former kind on account of very poor mechanical balance.

Ques. Is it possible to perfectly balance an engine by counterweights?

Ans. No; an engine may be balanced by counterweights to run at a certain speed with no perceptible vibration, but a variation below or above this speed will throw it out of balance.

Ques. How is a multi-cylinder engine balanced?

Ans. The arrangement of the cranks of a multi-cylinder engine produces a mechanical balancing effect in itself, but in order to reduce the vibration to a minimum, timing of the explosions in the various cylinders is necessary.

Answers Relating to Timing

Ques. How is the timing of the valves effected?

Ans. By arranging the cams which operate the valves, so that successive firing cylinders are on opposing cranks.

Ques. Explain this by referring to the four cylinder engine in fig. 121.

Ans. Naming the cylinders from left to right, 1, 2, 3, 4, and assuming that cylinder #1 has just completed a power stroke, the next cylinder may be either #2 or #3, the third one must be #4, and the final one may be either #3 or #2, depending on which fired second.

Ques. How do automobilists ordinarily express the rotation of firing?

Ans. The engine fires 1, 2, 4, 3, or it fires 1, 3, 4, 2.

Ques. What else governs the firing, so far as balance is concerned?

Ans. The adjustment of the ignition mechanism must follow the same rotation as governed by the cam rotation.

Ques. Explain the best method of ascertaining the timing, as regards the firing of the successive cylinders.

Ans. The engine should be turned over slowly by hand. By watching the lifting of the inlet or exhaust valve stems, the point of ignition will come about one-half turn after the seating of the inlet valve on each cylinder.

Ques. What governs the ignition?

Ans. The timing device.

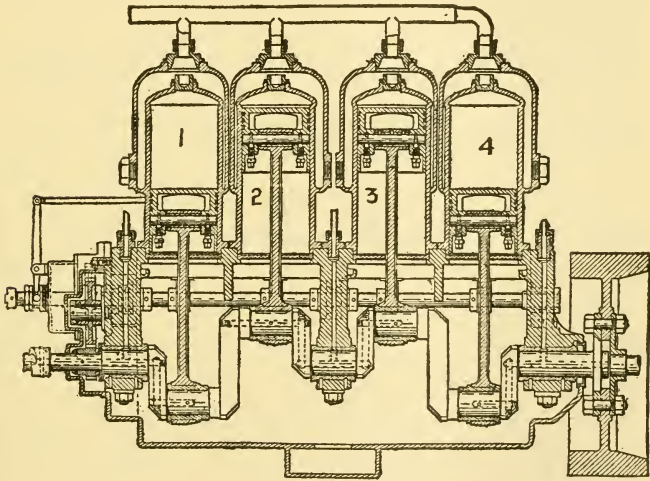

Fig. 121.—A typical four cylinder engine, showing position of cranks and working parts, including secondary shafts.

Ques. How is the timer adjusted?

Ans. The engine should be turned slowly until the inlet valve of cylinder #1 seats. It is then given an additional half turn; if the timer be fastened to the cam shaft by a set screw, the latter may be loosened and turned around until contact is made with one of the points, and the set screw tightened. The wire leading to spark coil #1

is connected to this point and the secondary wire of this coil to spark plug on cylinder #1. The engine is now slowly given another half turn, during which it should be noted which inlet valve seats; it should be that of cylinder #2 or #3. The primary wire of the second spark coil, counting from left to right, is connected to the binding screw of the timer point now in contact, and the secondary wire of this coil to the cylinder which has been found to be in action. The remaining cylinders are then tested in the same manner.

Ques. Should not the spark coils and cylinders whose numbers correspond be connected together?

Ans. For convenience spark coils are commonly connected in rotation, no matter what the firing order may be.

Ques. Would this method hold good on all engines?

Ans. No. Only on those equipped with jump spark ignition.

Ques. How should a "make and break" spark be timed for firing?

Ans. The engine is turned over until the inlet valve of cylinder #1 seats, then given another half turn until piston #1 is at the top. The "snap release" is now adjusted on the sparker until the contact breaks; the same method applies to the other cylinders, determining their succession as before.

Ques. Why must the position of the piston be determined more accurately than with the jump spark in a make and break spark engine?

Ans. As a rule, a make and break device has not such a wide range of advance, and if the retarded spark should not take effect at the dead center, the spark could not be sufficiently advanced for the highest speed.

The dead center of an engine may be determined as follows: At some easily accessible place near the rim of the fly wheel, a

pointer is fastened to the frame of the engine. At the top of each cylinder there is, usually a plug or pet cock, which should now be removed. Next, having procured a smooth stick of wood, or a thin iron rod which will fit loosely through the hole in the top of the cylinder, it is inserted into the cylinder so that it rests upon the piston. The stick should be kept vertical. The engine is turned so that the stick appears to be in the highest position, and a mark made on the stick with a pencil at the edge of the hole. Another pencil mark is made about $\frac{3}{4}$ or 1 inch from the first mark. Now the engine is turned until the second mark corresponds with the edge of the hole, and a mark is made on the fly wheel corresponding with the pointer which has been fastened to the frame. The engine is turned over past the bottom center, until the mark again registers with the edge of the hole; at this point a mark is made on the fly wheel corresponding to the position of the pointer. With a pair of dividers or a flexible rule, the distance between these marks is bisected, and marked. This latter mark is turned to the pointer, and cylinder #1 is on its exact top center.

Ques. Would the top centers of the other cylinders have to be found the same way?

Ans. No, the other centers may be found from the first obtained mark on the fly wheel, thus: in a four cylinder engine #4 would have the same mark as #1. For #2 and #3, another mark will have to be placed directly opposite the one of #1 and #4. In a six cylinder engine, one of the remaining cylinders would have a mark corresponding with the first, while a mark for each pair of the other cylinders would have to be placed at 120 degrees from the first mark, commonly spoken of as "placing them on thirds."

Ques. To what type of engine do the above explained methods apply?

Ans. To engines that are supplied with an ignition battery or an ignition dynamo.

Ques. In what way do engines equipped with a magneto differ from those equipped with a battery?

Ans. The magneto itself has to be "in step" with the engine.

Ques. Is there a difference between the timing of a high and of a low tension magneto?

Ans. There are certain points in the revolution of a magneto when the intensity of the spark is greatest; this should be taken advantage of whether it be a high or low tension magneto.

Ques. How should a low tension magneto with make and break spark be adjusted?

Ans. The sparking mechanism is adjusted the same as if a battery or dynamo were used, adjusting the various cylinders independently. The magneto, however, must be adjusted so that the most intense spark takes place at the moment of "break" of the contact.

Ques. Explain a simple and practical way of timing a magneto.

Ans. If the engine has been equipped with a magneto, the drive gears are marked on their rims so that with the marks on the different gears corresponding with each other, the magneto is in step with the engine. In such a case, if the gears have been shifted, it is a simple matter to replace them. If, however, no marks be present, the wires are connected to the terminals, and one of the valve chambers opened so that the spark points can be seen. The engine is now turned rapidly over by hand, and the spark noted. Marks are made on the gears with a pencil so this position can be found again if necessary. The idler gear is now shifted a couple of teeth, and this position indicated with a different mark; the engine is again turned and the spark noted. This process is repeated, shifting the gears a couple of teeth each time. The mark corresponding with the best spark should be selected and a permanent mark put on the gears.

Ques. What is important to observe when attaching a magneto to an engine?

Ans. That the drive and driven gears be keyed to their shafts, after the right position is found.

Ques. When the magneto has been timed to give the best spark at the top center, will advancing the spark lever make any difference?

Ans. The spark would not be as intense if the speed of the engine remained constant, but as the spark is advanced for high speeds only, the increased speed of the magneto will more than make up the deficiency and produce an even better spark.

Ques. Is the speed at which the magneto is driven important?

Ans. As there are two dead points during each revolution of the magneto, it should be geared so that none of the dead points correspond with the sparking periods.

Ques. How may a low tension jump spark magneto be timed?

Ans. When equipped with a multiple unit coil and timer, the same rules as applied to a battery equipment will be applicable, but the magneto may be timed the same as for the make and break engine, by turning and testing the spark. The spark plugs may be taken out and laid on the cylinder, with the cables connected, thus making the spark visible.

Ques. When a distributor is used, will there be any other points to observe in timing?

Ans. The distributor must be timed so that the rotor contact registers with one of the terminals for the spark cables for each cylinder before the spark is to take place. The contacts must follow the regular firing order of the cylinders.

Ques. If the magneto be equipped with a self-contained coil, would this make any difference in timing?

Ans. The same rules hold true; the only difference is in the wiring.

Ques. How is a high tension magneto timed?

Ans. The cables must be connected to the spark plugs in the regular firing order of the cylinders to determine the order of sparking of the plugs. They may be laid on the cylinder heads while the magneto is being turned over. The gears must be shifted one tooth at a time until the spark takes place at the right time, which is at about the top center when retarded.

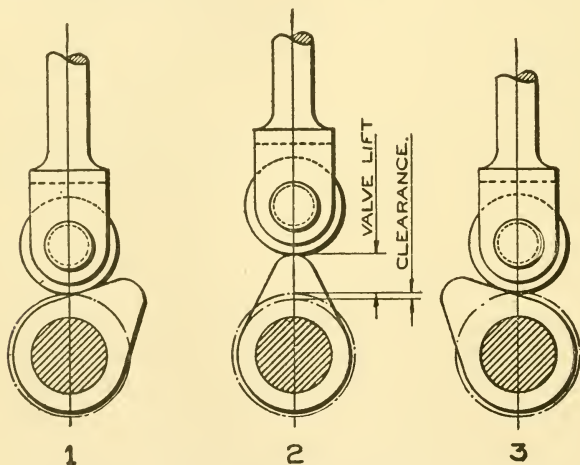

Figs. 122 to 124.—The successive position of a valve lifting cam.

Ques. How is the speed of a magneto determined?

Ans. By the number of cylinders, as well as the cycle of the engine.

Ques. What would be the proper speed of a magneto for a four cylinder, four cycle engine?

Ans. Since there must be four explosions for each two revolutions, and as each revolution of the armature produces two sparks, there must be one revolution of the armature for each revolution of the engine.

Ques. What would be the magneto speed for a three cylinder, two cycle engine?

Ans. Since three explosions take place per revolution, the armature must make one and one-half revolutions for each turn of the crank shaft.

Ques. If the cam shaft gears should be shifted, how would this affect the engine?

Ans. It would throw the entire valve motion, as well as the ignition device, out of time.

Ques. What is most important to observe before starting to time?

Ans. To examine the valve gear to ascertain whether the valves open and close at the proper time.

Ques. If the valves be out of "time," what is the proper way to proceed?

Ans. First examine the valve stems and push rods for lost motion, which should be no more than the thickness of heavy paper.

Ques. If this lost motion in the valve stems and push rods has been taken care of, should the gears be disturbed?

Ans. No, the engine should again be turned over and the valve action observed, when it will be found that the valves open earlier and close later.

Ques. Why should lost motion affect the valve action thus?

Ans. Referring to figs. 122 to 124, it will be seen that the cam raises the roller, including the push rod, to its full height. If however, there be a space, equal to the clearance indicated by the dot and dash circle, between the push rod and the valve stem, the push rod has to raise an amount equal to the clearance before it has any effect on the valve, and the cam has turned into position 1, and, after passing position 2, is commencing to close, the lost motion would affect it in the opposite way, as shown at 3, thus reducing the time of opening materially.

Ques. If after taking care of the lost motion, the valve mechanism is found to be out still, what will be the next step?

Ans. To change the position of the cam shaft drive gears with respect to the driving gear until the correct timing is obtained.

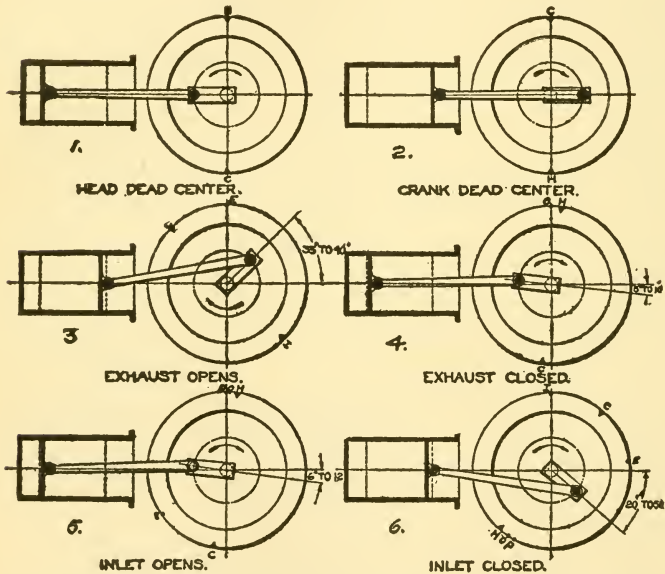

Figs. 125 to 130.—Valve timing diagrams, showing timing of valves for one cylinder engine.

Ques. What is meant by the valve being late?

Ans. The valves open and close late as compared to the movement of the piston.

Ques. Explain this by referring to a diagram.

Ans. In figs. 125 to 130, at 1, an engine is shown at the head center, and at 2, the same engine is shown at the crank center, the rotation being indicated by the arrow. At 3, the

position of the crank at exhaust opening is shown, which varies from 35° to 40° from the bottom center of the power stroke in various engines. At 4, the exhaust closes about 5° – 10° beyond the top center of the exhaust stroke. At 5, the inlet opens about two degrees after the closing of the exhaust, and at 6 the inlet valve closes and compression commences. Now, if by turning the engine over, the exhaust valves be found to seat at or before the dead center, it is plain that it closes 5° – 10° too early, and must have opened the same amount too early. Also, if the inlet valve should be found to open on or before the top center, it must also have closed too early, and thus prevented the engine taking a full charge.

Ques. Is the operation of the exhaust and inlet valves dependent upon each other?

Ans. If all of the valves be operated by the same cam shaft, the valves are bound to be "in step" with each other, providing there is no excessive lost motion, but if one of the valves be early or late, it is evident that they are all out of time.

Ques. What might happen if the exhaust and inlet valves be operated by separate cam shafts?

Ans. Both sets of valves may be out of time with each other, at the same time being out of time with the pistons, or one set may be in time with the pistons, while the other set is out of time.

Ques. Could an engine run under any of the above named conditions?

Ans. The valves may all be considerably out of time, and the engine will still run but at the expense of reduced power, increased fuel consumption, and excessive vibration.

Ques. How is improper timing detected?

Ans. By unsteady action, especially at the higher speeds.

Ques. If the valves be out of time, and there be no lost motion, what must be done?

Ans. One of the pistons, say, # 1, in fig. 121 is put on top center, a space amounting to about 5° – 10° is then marked off on the fly wheel rim, and the engine turned ahead until this mark comes even with the center pointer; the gears of the exhaust cam shaft are then shifted so that the exhaust cams just allow the valves to remain clear of their seats. The engine is then turned ahead about 2° , and the inlet valve shaft shifted until the inlet valve commences to raise.

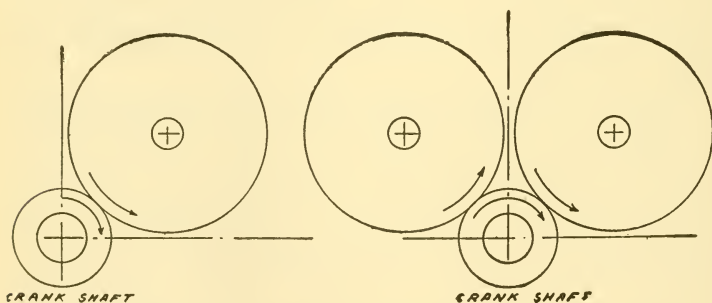

Figs. 131 and 132.—Diagrams showing rotation of cam shafts with a direct gear drive.

Ques. When shifting the cam shaft to make the valves earlier or later, should it be turned respectively, with, or against the direction of rotation of the crank shaft?

Ans. That depends upon the gearing. If the cam shaft gears mesh directly into the crank shaft pinion, the cam shafts revolve in an opposite direction than the crank shaft, and to make the valves earlier, the cams must be turned in the direction followed by the cam shafts, which is opposite that of the engine. Most engines have an idler gear between the crank shaft and the cam shaft gears; in such a case the cam shafts revolve in the same direction as

the crank shaft, and the cams shift **with** or opposite the engine to make them respectively early or late. This is illustrated in figs. 131 to 134.

Ques. If all valves be driven from one cam shaft, is it possible that one or more of them may be timed correctly, while the others are out of time?

Ans. On some engines the cams are made independent from the cam shaft, and are keyed to the latter, hence, it is possible that, in overhauling the engine, some of the cams may have been replaced wrongly.

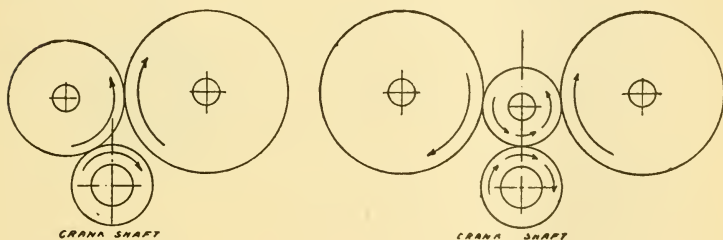

Figs. 133 and 134.—Diagrams showing rotation of cam shafts when an intermediate idler is used.

Ques. Is this possible if the cams be forged with the shaft?

Ans. Although the cams cannot be shifted out of time with each other, it is possible that the surface of some may be worn more than others, or on such engines where the cams act upon rollers carried by the end of the push rod, as in figs. 122 to 124, or by a carrier as in fig. 135, the roller and pin may be worn to such an extent as to make proper timing impossible, without removal of the worn parts.

Ques. Could this lost motion be taken care of when adjusting the lost motion between valve stems and push rods?

Ans. No, between valve stem and push rod only the lost motion in the direction of the valve travel can be

adjusted. The lost motion in the rollers, the carrier suspension, or the push rod bushings, acts in a direction at right angles to the valve travel, and affects the timing in the manner shown in figs. 136 to 138.

Ques. Will wear of the gear teeth affect the timing?

Ans. Very little, even if the teeth be worn considerably, the difference between the diameter of the gears and that

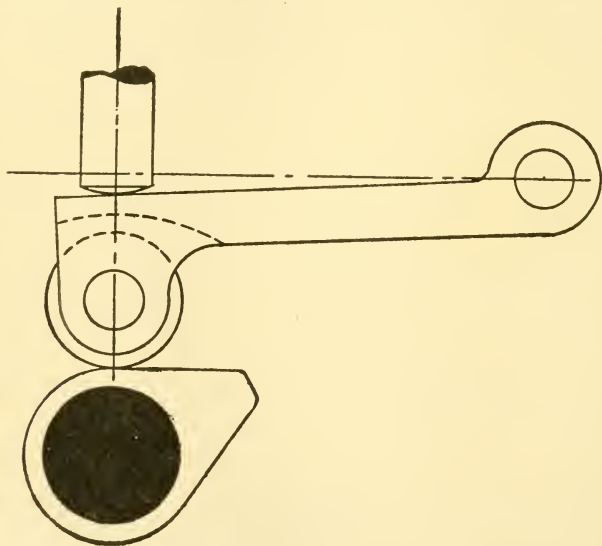

Fig. 135.—Valve cam device with roller mounted on carrier. This design is frequently used to reduce the side thrust upon the push rod.

of the cams is so great that the gears would be worn out before the timing would be materially affected.

Ques. What would be the main objection to lost motion in the gear teeth?

Ans. The noise. When the cams raise the valves against the spring action, the tension upon the teeth is upon their driving faces, while when the valves seat again

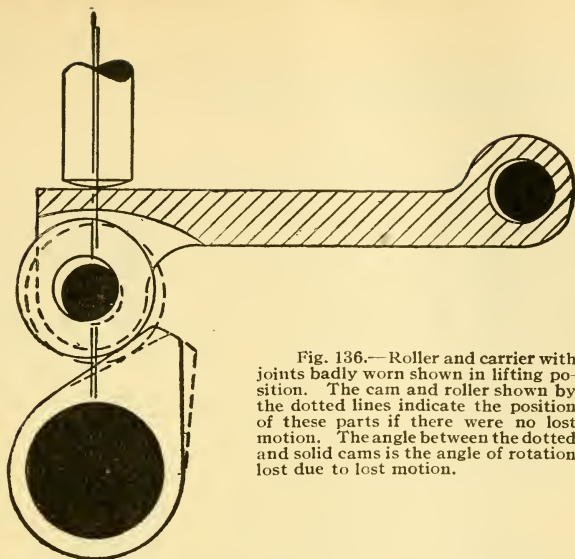

Fig. 136.—Roller and carrier with joints badly worn shown in lifting position. The cam and roller shown by the dotted lines indicate the position of these parts if there were no lost motion. The angle between the dotted and solid cams is the angle of rotation lost due to lost motion.

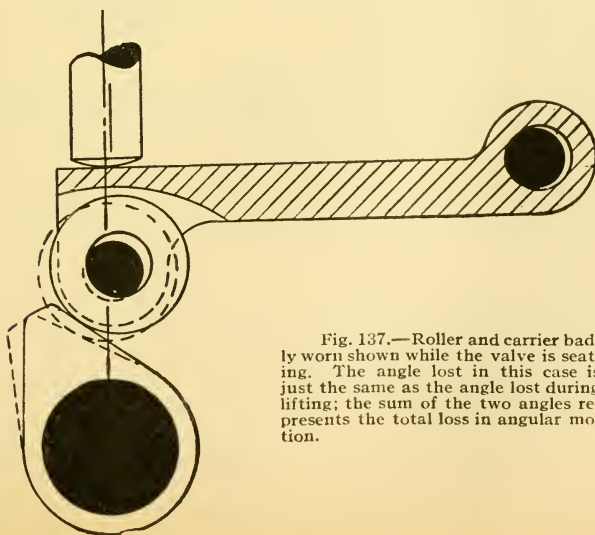

Fig. 137.—Roller and carrier badly worn shown while the valve is seating. The angle lost in this case is just the same as the angle lost during lifting; the sum of the two angles represents the total loss in angular motion.

by the spring action, the tension upon the teeth is on the reverse side, causing the gear teeth to clatter fore and back several times during each revolution.

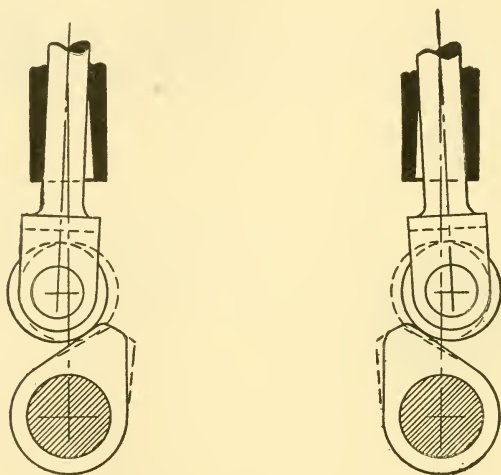

Fig. 138.—Valve push rod with roller shown in lifting and seating positions, showing the serious defects of a worn push rod bushing. The dotted cams and rollers indicate the position these parts would have with the same amount of lift if there were no lost motion.

GAS ENGINE OPERATION

The management of an engine embraces, in addition to the attention given the engine, the adjustment and care of the fuel, cooling, and ignition systems. A knowledge of ignition and the carburetter therefore is the chief requisite for success. A careful study of the chapters

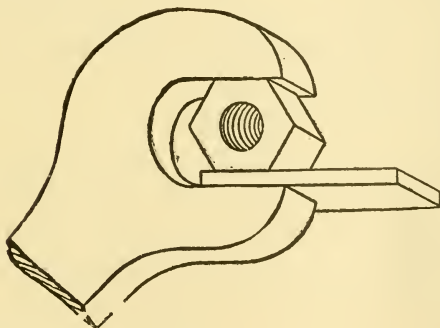

Fig. 139.—Illustrating the adaption of a large wrench to a small nut. After the wrench is applied to the nut or bolt head, in the ordinary way, with one hand, and before beginning to turn it, the wrench jaw is packed with the blade of a screw driver, or with a bit of metal or hard wood held in the other hand, as shown in the cut.

devoted to these subjects is especially recommended. The automobile engine, although having reached a high degree of perfection is a piece of machinery requiring the same intelligent attention in its care and management as any other high class machine, in order to obtain the best results.

For successful operation of a gas engine, the operator must not only understand the necessary conditions of

working and control, but must know how to meet the numerous disorders and mishaps that may be encountered as those arising:

1. From faulty construction, which, however, will be seldom experienced with well made automobiles;
2. From careless or ignorant handling, such as:
 - a. Insufficient lubrication;
 - b. Faulty adjustments;
 - c. Exhaustion of the fuel, ignition current, or jacket water;
 - d. Racing;
 - e. Overheating.
3. From any one of a number of disorders in the ignition apparatus;
4. From poor gasoline, or faulty adjustment of the carburetter;
5. From worn or broken parts.

By far the greater proportion of gas engine troubles result from some derangement of the sparking system. Second in importance come troubles with the fuel mixture. Both the electrical apparatus and carburetter may require attention.

Answers Relating to Supplies for the Engine

Ques. What supplies must be provided before starting the engine?

Ans. Gasoline, lubricating oil, and circulating or cooling water.

Ques. How should the gasoline tank be filled?

Ans. The liquid should be strained to guard against the carburetter passages becoming clogged by foreign matter

that may be contained in the fuel. A chamois skin or wire netting having a very fine mesh may be used as a filter.

Ques. What substitute is sometimes used for gasoline?

Ans. In localities where gasoline is very expensive, as in California, **number one distillate** may be used, which works nearly as well except that it is necessary to prime the carburetter with gasoline in starting the engine when cold.

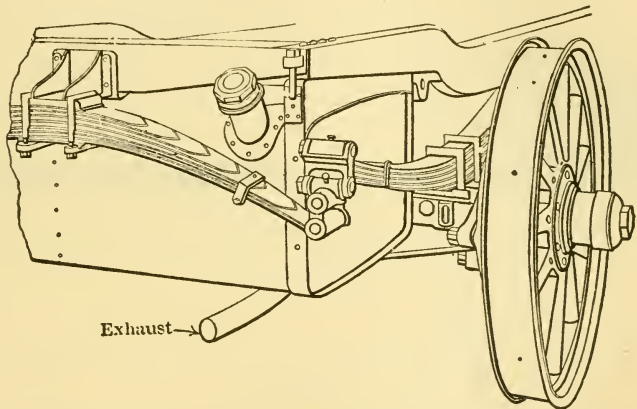

Fig. 140.—Showing usual location of tank and exhaust pipe. The latter passes under the tank and the construction should be such that the pipe is well secured to prevent vibration.

Ques. What next should be done after filling the tank?

Ans. The filler cap should be replaced, and care taken that the small hole in the center of the cap is open so that air may be admitted as the fuel is used. This prevents the pressure within the tank becoming less than that of the atmosphere.

Ques. What attention should be given to the fuel supply pipe?

Ans. The fuel supply valve should be opened, and after sufficient time has elapsed for the float chamber of the carburetter to fill, it should be noted that the float pin is up.

When the float pin is up it indicates that the float chamber has received a supply of gasoline from the tank. If the pin remain down, there is some obstruction in the supply pipe preventing the flow of the liquid to the carburetter.

Ques. What attention should the radiator receive?

Ans. It should be filled with clean water. As with the fuel, the same care should be taken with the water,

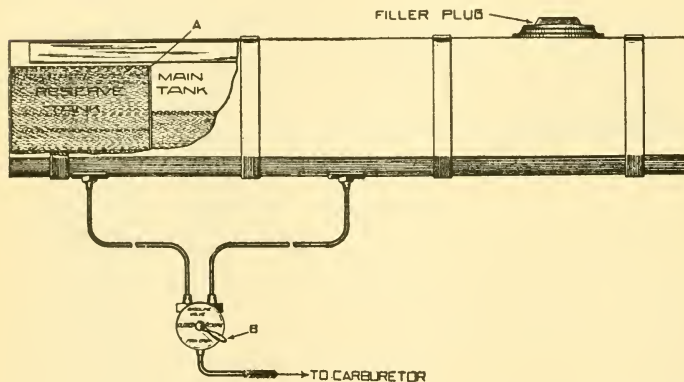

Fig. 141.—The Franklin gasoline tank. The tank is divided by the wall A into two compartments, called *main* tank and *auxiliary* or *reserve* tank. It should be noted that in order to fill the reserve tank there must be enough gasoline in the main tank to flow over the dividing wall A. Each tank has its own outlet pipe, but they both run to the same valve, which is mounted on the sill below right front seat. This valve is so arranged that when the lever B is horizontal and pointing toward the rear (thus covering the word "closed") gasoline from both tanks is shut off. When the lever B points down, the gasoline in the main tank is free to flow to the carburetter. When the lever B is horizontal and pointing forward, the gasoline is free to flow from the reserve tank to the carburetter. Thus, when the supply of gasoline in the main tank is exhausted, there is a reserve supply obtainable by turning the valve into reserve position.

to see that it is free from any foreign matter; the latter may clog the restricted passages of the radiator and impair its efficiency.

After filling the radiator, it is advisable to turn the engine over several times to allow the water to circulate through the cooling system and fill any air pockets that may have formed:

this will be indicated by a lowering of the water level in the radiator, in which case more water should be added. If the car be driven in winter, a good non-freezing solution should be used.

Ques. What extra care should be taken when preparing for a long run?

Ans. On such occasions, both the gasoline and water tanks should be tested.

Ques. How may the amount of fuel and water in the tanks and radiator be determined?

Ans. Some automobiles have glass gauge tubes fixed to the fuel and water tanks so that the level of the liquids may be determined at a glance. In others, it is a simple matter to test the level by inserting a stick in the filling hole and noting the height to which the liquid rises on it: the fuel level may be tested in this way, if the stick be withdrawn quickly and examined before evaporation takes place.

Answers Relating to Lubrication and Lubricants

Ques. Having filled the fuel tank and radiator, what next should receive attention?

Ans. All the working parts requiring lubrication. In general it is well to adhere to the manufacturer's instructions in the performance of this task. The transmission case, the steering gear case, and the rear axle housing may be supplied with a mixture of oil and grease which insures lubrication for the gears and bearings. The transmission case requires, under ordinary conditions, gear grease mixed with heavy oil about once a month. The bevel gears, differential, steering gear, and wheels are sometimes packed with a non-fluid lubricant sufficient to last several months.

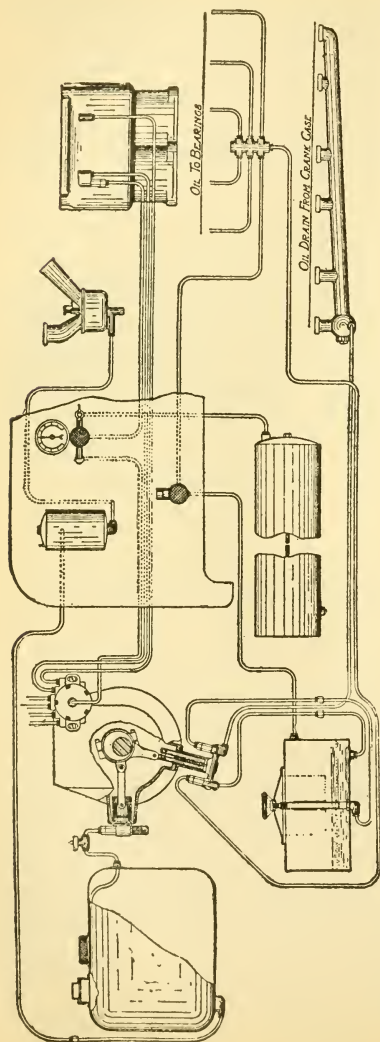

Ques. What quality of oil is required for the cylinders?

Ans. Gas engine cylinders require an oil quite different from that used for steam engines. Owing to the high cylinder temperatures, a gas engine must have an oil possessing a high fire test. As the average cylinder temperatures may be said to be from 300 to 400 degrees Fahrenheit, an oil should be used having a fire test higher than the latter figure; the flashing point should not be less than 360 degrees.

Fig. 142.—Diagram of the Winton lubrication system. A pump operated by an eccentric on the rear end of the crank shaft takes oil from the oil tank at the left side of motor and delivers it through leaders to the crank shaft main bearings and front gears. A second pump operated by the same eccentric draws oil from the crank case, where it is deposited by gravitation, and returns to the oil tank, where it passes through a filter before being used again. There is a sight test on the dash; the cylinders are fed by splash, while the transmission gears and clutch run in an oil bath.

Ques. Should a different grade of oil be used with air cooled cylinders?

Ans. Yes; air cooled cylinders being hotter under working conditions than water cooled, require a lubricant capable of withstanding higher temperatures than that required by the latter.

Answers Relating to Adjustments Preliminary to Starting

Ques. What important adjustments should be made before starting the engine?

Ans. It is necessary: 1, that the brake be set, in order to release the clutch so that the car cannot start until desired, 2, that all parts of the lubricating system are in working order, all connections opened, and the supply of oil sufficient, 3, that the ignition circuit be closed, which involves examination of all switches, to insure certainty that they are on the "closed" point, 4, that the carburetter control levers be placed in position for ensuring the richest mixture under operating conditions, in order that, even with the low suction at starting, sufficient power may be obtained for a good headway, 5, that the lever on the spark control quadrant stand at the extreme "back" position, fully retarding the spark, and 6, that the throttle be opened partly; it should not be opened any further than necessary in order that the engine will not race after cranking.

Ques. How should the spark and throttle be adjusted before starting?

Ans. On account of the slow speed at which the engine is turned over in cranking, it is necessary that the throttle have a large degree of opening and that the spark be fully retarded because of: 1, the weak suction of the piston at

slow speed, 2, the need of ensuring a mixture that will ignite under such conditions, and 3, the danger of bodily injury from a "back kick" of the engine, which is liable to occur with an early spark at slow speeds.

It may be well to repeat here that the operator should never attempt to crank the engine until:

1. The brake is set, releasing the clutch;
2. The transmission lever is placed in the neutral position.
3. The spark fully retarded.

The neglect of this precaution may be followed by serious injury.

Answers Relating to Cranking

Ques. What is cranking?

Ans. The act of rotating an engine by means of the crank handle in order to start it. Turning it over a few times by hand will—if all the mechanism be in proper working order—cause the engine to take up its cycle and continue to rotate.

Ques. What is the proper method of cranking?

Ans. The operator faces the car and grasps the crank handle with the four fingers of the right hand, allowing the thumb to lie along the handle. The crank is now raised to its highest position, pressed in towards the car and turned downward. If, at the beginning of this movement, it turns hard indicating compression, the operator should allow the crank to spring out of engagement with the shaft and revolve backward far enough so that he will pull "up" against compression.

An engine should never be cranked downward against compression, for in case the spark has not been fully retarded, the pressure of the early explosion may overcome the momentum of the fly wheel and drive the handle violently backward, resulting in, perhaps, a seriously sprained wrist or broken arm.

Ques. What method should the beginner pursue?

Ans. It is advisable that he make two or three turns with the switch off, then a final turn with the switch on, when the engine should start.

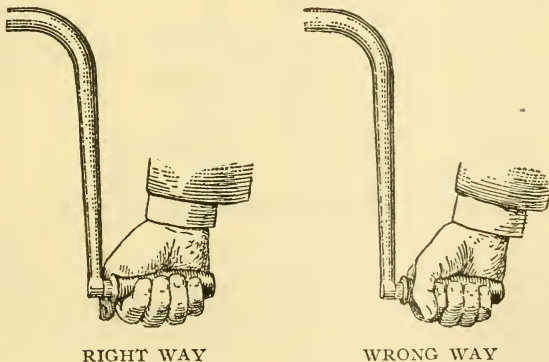

Figs. 143 and 144.—Illustrating right and wrong methods of cranking an engine. As ordinarily practiced, the hand is so placed that the thumb and fingers encircle it. Such a method is decidedly unsafe should the operator press down on the crank and a back fire occur. The correct method is to place the thumb on the same side of the handle that the fingers are placed, so that the handle is not entirely encircled, allowing the handle to slip out of the grasp when it is being pressed down, and permitting the fingers to release the handle if it is being pulled up, at the time of the back fire.

Another method consists in turning the handle till sure he is pulling **upward** against compression, then relieving the compression somewhat by partly opening and closing the relief cock after which the turn is quickly completed.

Ques. How may a multi-cylinder engine be started when the compression is good?

Ans. The primary switch is first opened, and the engine turned over a few times until a fresh charge is obtained in each cylinder. The operator then mounts the seat, and after closing the switch, the spark lever is quickly pushed forward as far as it will go. This operation usually causes a spark in one of the cylinders and starts the engine.

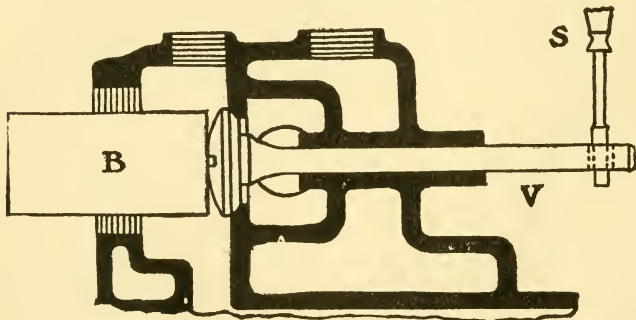

Fig. 145.—Method of grinding valves in horizontal cylinders. A block of steel B is held against the head of the valve V and the latter rotated on its seat by means of a screw driver blade S inserted in the slot in the stem, the face having been previously trued by a truing tool. In cases where the stem of the valve has no slot, a pair of gas pliers can be used to grip it, being careful in so doing not to mutilate the threads thereon.

Ques. What should be kept in mind while cranking?

Ans. The operator should not forget that a few rapid turns of the crank handle will do more towards starting an engine than many minutes of slow grinding.

If there be good compression and the engine will not start after four or five turns, it is useless to continue.

Ques. How should the spark and throttle be adjusted after starting?

Ans. When the engine has come to speed, the spark is advanced, and the throttle opening reduced.

On account of the spark and throttle adjustments necessary in cranking, the engine, when started, will begin to race unless it be fitted with a governor, hence, the operator should reduce the throttle opening without delay and advance the spark so the engine will run at its slowest speed while the car is standing. The throttle lever should be pushed all the way back, this does not close the valve entirely but leaves sufficient opening to supply the minimum charge to the engine.

If there be a mechanical governor on the engine, the throttle will shut down automatically as the engine speeds up.

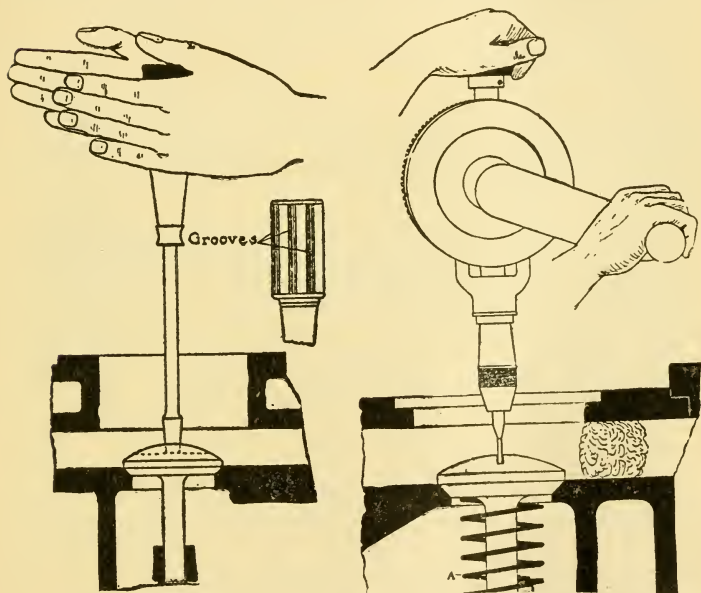

Fig. 146.—Method of using a screw driver for valve grinding. A handful of waste or a cloth is put in the valve port to protect the cylinder, and the valve face coated with a paste of fine emery powder and oil and put in place. The handle of the screw driver is now held between the palms of the hands as in the sketch, and a series of oscillations through a small arc given to the valve by moving the palms in opposite directions. After about thirty of these oscillations have been given, the valve is lifted from its seat, given a half turn, and resealed for further grinding in the same manner. This operation should be continued with occasional additions of oil and emery, until the valve face and the seat appear to be bright for their full width around the circle.

Fig. 147.—Method of grinding a valve with a drill stock. A screw driver bit is inserted in the chuck and the operation conducted as in the case where a screw driver is used. The crank should be rocked through a small arc instead of being rotated. The spring A is fitted within the valve chamber to unseat the valve when it is desired to examine it.

Answers Relating to Defective Engine Operation

Ques. In general, what causes failure to start?

Ans. In most cases this is due to some faulty adjustment or defect of the carburetter or ignition system.

Ques. What are the indications of misfiring?

Ans. Misfiring, that is, the missing of one or more cylinders, may be recognized by irregularity of motion, gradual slowing down, and, generally, by **after firing**, that is, explosions in the muffler.

If the trouble cannot be located in one of the cylinders, the inference holds that there is some general derangement of the ignition circuit, or, the fuel mixture is not right.

Ques. What is **back firing**?

Ans. The ignition of the charge at such a point in the cycle that the motion of the engine is reversed.

Ques. What is "back kick?"

Ans. The result of back firing during cranking. If back firing should occur while the operator is holding the crank, it produces a back kick, which is liable to dislocate his shoulder or do other injury unless the crank throws off automatically.

The term **back firing** is also applied to an explosion occurring during, or at the end of the inlet stroke, when the gas in the carburetter mixing chamber is ignited. This is due generally to a loose or defective inlet valve, a pitted inlet valve seat, smoldering carbon residue in the cylinder space, or a spark due to a disarranged ignition circuit. The presumption is that the inlet valve needs grinding.

Back Firing or ignition at the wrong point in the cycle, with reversed piston movement, must be carefully distinguished from

after firing, or explosions in the muffler or exhaust pipe. Occasionally the same term is erroneously applied to both mishaps.

Ques. What are the causes of back firing?

Ans. It may be caused by the overheating of the cylinder walls, due to insufficient heat radiation (in an air cooled engine) or too little jacket water (in a water cooled engine).

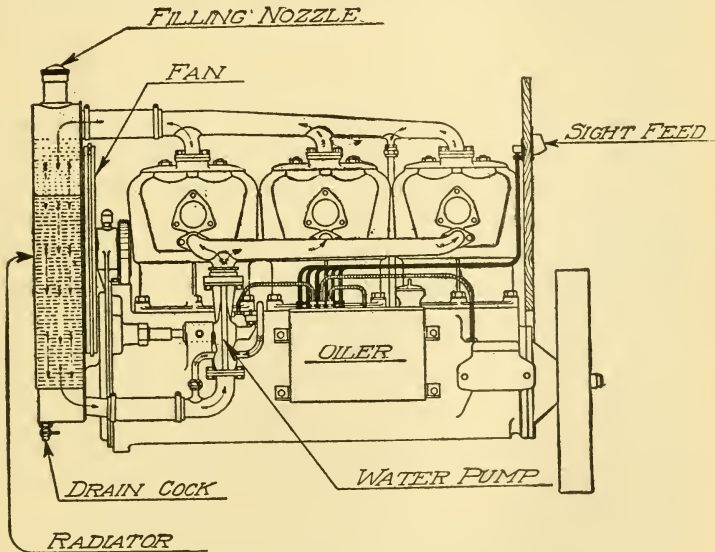

Fig. 148.—Thomas engine installation. At the side is seen the water pump and lubrication system; the figure also illustrates the connection between the pump and the water jacketed carburettor for warming the mixture in cold weather.

This should emphasize the necessity of keeping the water supply sufficient for all needs, and of assuring the proper operation of the circulation system, pump, radiator, etc., before starting the engine.

Back firing is sometimes caused by soot deposits within the combustion space, due to carbonization of excess oil, etc. Such deposits will readily ignite and smolder, and will thus furnish an almost certain source of ignition during the compression stroke.

Ques. Name some defects which cause difficulty in starting?

Ans. 1. An obstruction in the jet of the carburetter, 2, a too weak suction, 3, insufficient tension of the auxiliary air valve spring, or 4, insufficient retarding of the spark.

Ques. What is "running down"?

Ans. This term applies to the faulty operation of an engine when it starts well, runs for awhile, then slows down and stops.

Ques. State some of the causes of running down.

Ans. The principal causes are: 1, water or sediment in the carburetter, 2, loose connections, breakdowns, or any other disarrangement of the ignition, such as would otherwise interfere with starting, 3, weak or imperfectly recuperated battery—frequently the latter—that suddenly fails to supply current, 4, a leak in the water jacket that admits water to the combustion space, 5, "seizing" or sticking of the piston in the cylinder on account of failure of the cooling system, 6, heated bearings that seize and interfere with operation, 7, poorly matched or badly adjusted new parts, particularly pistons, that cause heating and perhaps seizing from friction, and 8, lost compression, from stuck valves, leaky piston, etc.

Seizing of the piston on account of failure of the cooling system may result, in a water cooled cylinder, from:

- a. Exhaustion of the water;
- b. Stoppage in the pipes or pump;
- c. Breakdown of the pump;
- d. Failure of the oil supply;

In an air cooled cylinder, seizing may result from:

- a. Insufficient radiation surface;
- b. Obstructed air circulation.

Ques. Mention some conditions that will cause a loss of power without misfiring.

Ans. The chief cause for an engine to fail to deliver its full power with good ignition is poor compression. A fuel mixture either too weak or too strong will reduce the power of the engine. If the bearings be too tight, there will be a loss of power due to the additional friction set up; bearings when too tight will heat, and a touch of the hand

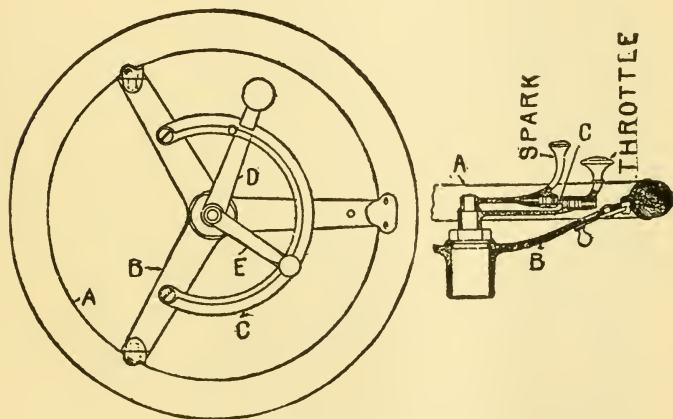

Fig. 149.—Steering wheel and attachments. A is the wheel rim; B, a spoke or arm of the three arm spider; C, sector for sliding arms, D and E; D, throttling arm and handle; E, spark regulating handle. The throttle is opened by moving the handle clockwise around the sector; the spark is advanced by moving its handle in the same direction.

will give indication of their condition. Another source of loss of power is a defective clutch which slips and does not transmit all the power delivered by the engine. Brake rods sometimes get out of adjustment, allowing the band to remain in contact with the drum, thus absorbing more or less power.

Ques. What may be said of low compression?

Ans. Low compression means absence of a sufficient quantity of gas mixture to give a good power effect. When little or no compression manifests itself as a resistance to cranking, it is certain that the operation of the engine will be defective, provided it can be started at all. If the engine should lose compression after it has started, it will misfire and slow down.

Ques. State the causes of low compression.

Ans. This condition results from a leak in the combustion chamber, due to: 1, a sticking (automatic) inlet valve, 2, pitted or corroded exhaust valve, 3, a weak spring on the exhaust valve, 4, loose or open compression cock, 5, leaky piston, 6, defective gasket in the cylinder head, 7, worn or loose thread at the insertion of the spark plug, 8, broken valve or valve stem, 9, worn or scratched cylinder wall, and 10, a valve stem that is so long that it touches the end of the push rod when the engine is cold.

Ques. What should be done in case of low compression?

Ans. All the joints and cylinder gaskets should be examined for leaks.

Ques. How may leaks at the openings into the cylinder be detected?

Ans. The escape of compression around the spark plug, relief cock, or other opening into the cylinder may be detected by the application of a little soapy water; if there be a leak it will be indicated by the formation of bubbles.

Ques. What indicates a leaky piston or a broken ring?

Ans. A leaky piston causes a hiss inside the cylinder; a sharp hiss indicates a broken ring.

Ques. What causes the inlet valve to stick?

Ans. Usually an incrustation of gummed oil.

Ques. How should the length of the valve stem be adjusted?

Ans. If too long, the end of the valve stem should be filed until a card can be inserted between the stem and the end of the push rod.

Ques. What causes a leaky piston?

Ans. Worn or broken piston rings; shifting of the position of the piston rings so as to bring the openings on their circumferences into line.

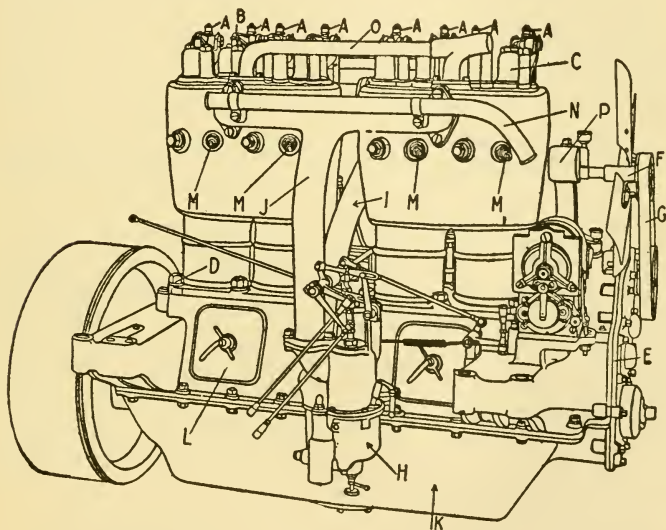

Fig. 150.—Pope-Hartford engine. A, valve operating lever grease cups; B, valve operating lever; C, valve cage cover; D, cylinder hold down nut; E, timing gear case cover; F, cooling fan; G, cooling fan belt; H, carburetter; I, carburetter hot air pipe; J, gasoline inlet upper pipe; K, engine crank case cover; L, engine crank case hand hole cover; M, spark plug; N, ignition wire tube; O, water return pipe; P, fan bracket.

Ques. What is a carbonized cylinder?

Ans. A cylinder whose walls and valve chambers during operation have become coated with a deposit of a hard, indurated form of carbon, similar to gas carbon. This carbon is

a deposit of heat decomposition of the fuel or lubricant, or both, under pressure, and in the presence of too little air for combustion.

Ques. How is the formation of carbon within the cylinder usually indicated?

Ans. By the frequent occurrence of pre-ignition, due to projecting points of red hot carbon within the cylinder.

Ques. What causes the formation of carbon in the cylinder?

Ans. Too rich a mixture almost invariably results in the formation of carbon, which also follows upon the use of oils that do not stand high enough temperatures, or that are otherwise of poor quality.

The formation of carbon is also caused by delayed opening of either exhaust or inlet valves, not providing enough time for the exhaust.

Ques. Describe the action of carbon in a cylinder?

Ans. Carbon, when present in lumps, will tend to become red hot and cause pre-ignition. Small particles may catch on the valve seats, holding the valves open and causing loss of compression and power. The carbon that catches in the piston rings and their grooves may so bend the rings as to prevent their even contact with the cylinder walls so essential to good compression, and, in addition, may score the cylinders.

Ques. How may carbon be removed from the cylinder?

Ans. It is scraped off with hard, sharp edged tools. For cleaning out the ring grooves a special tool should be used, made to fit so closely as to leave no deposit under its end or by its edges. Keeping the deposits moist with kerosene will facilitate their removal; soaking with kerosene for hours or even days will be still better. For surfaces that can be reached in this manner, and that will not be injured by the wear it will cause, finishing may be

done with coarse emery cloth, held in the hand or around a stick.

It is to be understood that it is a rather long and tiresome job at best, to thoroughly clean all parts of a badly carbonized engine, but the improvement in its power and running afterwards will more than compensate for the work expended by the owner.

A simple and effective method of removing carbon consists of inserting into the cylinder a set of scouring rings, and operating the engine for a few minutes on the remaining cylinders.

Ques. What precaution should be taken to reduce the formation of carbon?

Ans. To keep it to a minimum, the often recommended process of coal oiling the cylinders from time to time is to be advised, but even with this preventive regularly applied it occasionally becomes necessary to take off the cylinders, scrape out the combustion chambers, and clean the valves and pistons. The formation of carbon can be largely avoided by close attention to the carburetter, the lubricating, and ignition systems.

Ques. Why does a smoky exhaust cause considerable trouble?

Ans. The soot formed, is liable to take fire and smolder, causing pre-ignition, or even back firing, especially under heavy loads; moreover the operator in some restricted sections is liable to arrest.

Ques. What does dark colored smoke in the exhaust indicate?

Ans. An over rich mixture which ignites imperfectly.

Ques. What causes dense white smoke?

Ans. An excess of cylinder oil with a resulting deposit of carbon soot in the cylinder, or a poor oil.

Ques. What does a thin, blue or nearly invisible smoke indicate?

Ans. A correct mixture and good ignition.

An unpleasant odor in the exhaust is frequently mentioned as the one necessary evil of automobile operation. It is certainly nothing of the sort, and often indicates poor lubricating oil or too

rich a mixture, which involves waste of fuel. A good mixture, perfectly ignited, in a cylinder lubricated with high test oil, should have no especially bad odor.

Bad odors and smoke at starting are frequently produced by chemical conditions other than a poor oil or an over rich mixture. They are also common when running at slow speeds. Long continued, however, they constitute a trouble that demands earnest and careful attention.

Ques. What should be done in case of smoke in the exhaust?

Ans. The cylinder oil feed or the carburetter should be adjusted according as the color of the smoke indicates too much oil, or an over rich mixture.

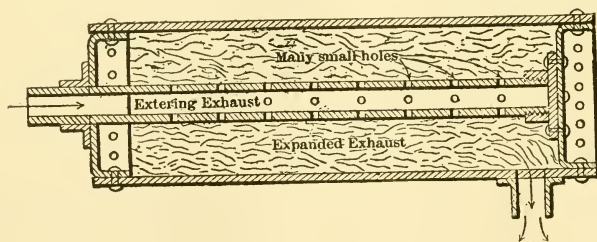

Fig. 151.—A simple form of muffler, as used on many cars, and which gives good satisfaction when well designed. It consists of a cylinder and a pipe so contrived that the pipe, which is drilled full of small holes, will admit the exhaust at high pressure, and as it is required to pass through a large number of small holes, it is split up and then expanded. The gas passes to the atmosphere in an uneven flow, at a pressure slightly above that of the atmosphere. This type of muffler is fairly efficient when well designed.

If an excess of cylinder oil be the sole trouble, reducing the rate of feed will decrease the smoke after a few revolutions of the engine. In adjusting the carburetter, the primary air inlet should be examined, as it may be partially closed by an accumulation of dust on the gauze screen.

If, after other relief measures have been tried, the smoke should persist, the cylinder interior must be cleaned at the earliest opportunity. This, of course, cannot be done until the engine is brought home and dismantled. To forestall further mishaps, the journey should be continued with as weak a mixture as possible. In cold weather considerable watery vapor will appear in the exhaust.

Ques. Explain the usual cause of after firing.

Ans. After firing or "barking," is commonly caused by misfires in one or more cylinders, which results from an accumulation of unburned gas in the muffler that is ignited by heat of the walls or by the exhaust of firing cylinders. Sometimes it may be due to a mixture, that is too rich or too weak, which burns slowly, continuing its combustion after passing into the exhaust. It also occurs frequently, when the spark is retarded, especially with heavy loads.

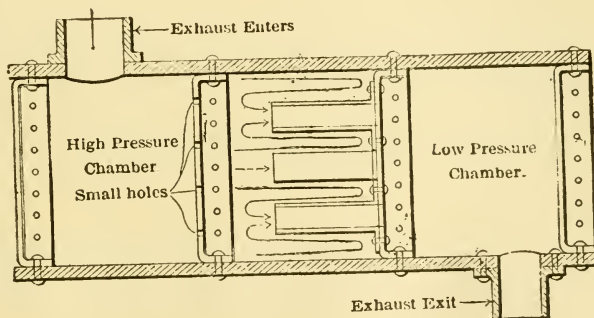

Fig. 152.—Simplex type of muffler, showing three chambers: a high pressure, intermediate, and low pressure chamber, so contrived that the pressure is reduced almost to zero before the exhaust makes its exit to the atmosphere. The volume of the high pressure chamber is equal to that of one of the engine cylinders; the intermediate chamber has twice the volume, and the low pressure chamber three times the volume of the engine cylinder.

No particular harm results from after firing since the explosion can seldom occur until the unburned gas comes into contact with the outer air.

Ques. In a multi-cylinder engine, explain a method of testing for a missing cylinder.

Ans. In practically all four cylinder engines the cranks of the second and third cylinders are in line, and are set at 180° to the cranks of the first and fourth, which are also in one line. Consequently, the pistons of the second and

third cylinders make their "in" strokes at the same time as the first and fourth make their "out" strokes. As a rule, the order of ignition is: first, third, fourth, second, which is also the order in which the primary circuit is closed by the timer, closing the circuits through the primary winding of each coil, in succession. In order, therefore, to determine which cylinder, if any, be missing fire, it is necessary only to open the throttle and advance the spark lever to the running position, giving the engine good power, and to cut out three of the four cylinders by depressing their coil vibrators.

If the engine continue to run with coils 2, 3 and 4 cut out, cylinder 1 is evidently working properly. Depressing vibrators of 1, 3 and 4 shows whether 2 is working; of 1, 2 and 4 whether 3 is working; and of 1, 2 and 3 whether 4 is working. On discovering the faulty cylinder, its plug may be tested and the fault corrected.

A similar method may be followed in the search for a missing cylinder of a three or six cylinder engine.

Ques. What other method may be employed to test for a missing cylinder?

Ans. A missing cylinder may also be found by low temperature of its spark plug and exhaust pipe, if the missing be long continued.

Ques. What sometimes causes the engine to run while the switch is off?

Ans. It occasionally happens that the switch becomes defective so that it does not break the circuit when in its "off" position. A most common cause for running with open switch is red hot plug points, also the heating to incandescence of some small particle in the cylinder, either loose or attached to the interior surfaces.

Ques. State a few causes of pre-ignition?

Ans. An incandescent particle or overheated cylinder will cause an engine to pre-ignite. Sometimes the rotor arm of the timer wears at the contact point, leaving a path

of metallic particles on the ring containing the stationary contacts, thus causing the current to flow to the stationary contact, via this path and causing ignition to occur before the proper time.

Answers Relating to the Carburetter and the Mixture

Ques. What is the effect of water in the carburetter?

Ans. This will often prevent the engine starting, and will impair its efficiency.

Water is frequently present in gasoline, and, particularly when the supply of fuel is low, is liable to get into the pipes and carburetter. Every carburetter has a drain cock at the bottom to let off the water that settles from the gasoline. The natural result of water in the carburetter is impaired or interrupted vaporization of gasoline.

Ques. What trouble is sometimes caused by water in the carburetter, in cold weather?

Ans. It is liable to freeze, preventing the action of the carburetter parts, and clogging the valves. Ice in the carburetter can be melted only by the application of hot water or **some other non-flaming heat**, to the outside of the float chamber.

Ques. What symptom indicates water in the carburetter?

Ans. There is strong evidence of the presence of water when the engine starts, runs fitfully, or irregularly, and finally stops.

Ques. What other defect will cause the engine to behave in much the same way?

Ans. Stale or low degree gasoline.

As previously mentioned, gasoline being a volatile essence, distilled from petroleum oil at temperatures ranging between 140°

and 248° Fahr., and boiling at between about 150° and 200° on the average, is a compound of several spirits of varying density, gravity and volatility. It follows therefore, that, unless stored in an airtight vessel, the lighter constituents are liable to escape.

Ques. How may gasoline become stale if the supply in the tank be in good condition?

Ans. It deteriorates on standing for any length of time in the float chamber.

The obvious remedy is to drain the float chamber and allow it to fill with a fresh supply from the tank.

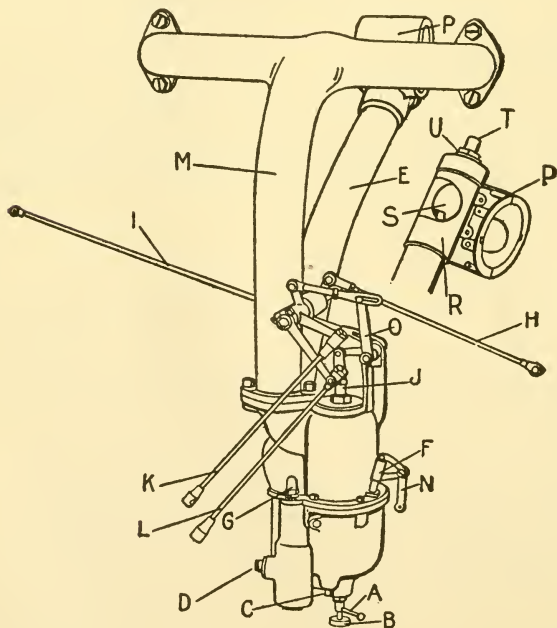

Fig. 153.—Center draught carburettor and connections. A, needle valve lock nut; B, needle valve; C, float chamber drain; D, fuel pipe; E, hot air pipe; F, primer plunger; G, float pin upper bearing; H, connection between intermediate lever and magneto operating lever; I, foot accelerator connection; J, throttle shutter; K, throttle control lower connection; L, ignition control lower connection; M, fuel inlet upper pipe; N, primer bell crank; O, throttle; P, hot air box; S, port hole; T, hot air adjustment; U, lock nut for same.

Ques. What is the effect of a very rich mixture?

Ans. If not too rich to ignite, it results in a heavy and ill smelling smoke from the muffler. The color of this smoke will determine the nature of the trouble.

Ques. How may an over rich mixture be caused?

Ans. This is usually caused by: 1, an air inlet clogged with dust or ice on the gauze; 2, a piece of grit or other substance, preventing closure of the needle valve, or 3, a leaky float, which has become partially filled with gasoline, and is, therefore, imperfectly buoyant.

A leaky float may be repaired by soldering; in doing this, a vent should be made at some convenient point, and the float cooled by placing it on a cake of ice, after which the vent is soldered leaving the air within at atmospheric pressure.

Ques. Name some of the causes of a poor mixture?

Ans. An excess of air drawn through some leak in the air pipe; water in the gasoline or a feed pipe or feed nozzle clogged with lint, grit or other obstructions.

It may occasionally happen, particularly after standing for a long period, that the valve of the carburetter sticks. This will interfere, of course, with proper feed of the fuel. To determine whether all parts are in good condition, it is desirable to flush or prime the carburetter by depressing the protruding end of the valve spindle, called the "flusher." This depresses the float and opens the valve; it also allows the liquid to enter the chamber, and proves that there is no obstruction in the passages.

Ques. How may a sufficiently rich mixture be obtained for starting, other than by depressing the float pin?

Ans. By partially closing, with the hand, the air inlet to the carburetter so that the increased suction will draw a greater quantity of gasoline, than otherwise, into the mixing chamber.

Ques. Is this method preferable to depressing the float pin?

Ans. Yes, because the normal action of the carburetter is restored sooner.

Ques. How may the quality of the mixture be determined?

Ans. Generally by its effect upon the operation of the engine.

Ques. In what other way may the quality of the mixture be determined?

Ans. If the cylinder cock or the spark plug be removed and a lighted match applied, the richness of the mixture may be judged by the color of the flame.

If the mixture be **too rich**, it will burn **yellow**; if **too poor**, it may not burn at all or **faintly blue**; if **just right**, it will **explode** and rush out of the opening to the danger of the operator's fingers; if the mixture seem to be **poor**, injecting a little gasoline from a squirt can, or flooding the carburetter, will prove whether or not the indication be correct.

Answers Relating to Ignition Disorders, and Adjustments

Ques. How should dry cells be connected for long periods of operation?

Ans. They should be arranged in series in two or more separate batteries, with switches that may cut all out of circuit, except the one in use.

The reason for this is that such cells are subject to deterioration while in use, and a new battery should always be at hand.

Ques. What causes deterioration?

Ans. It results: 1, from extended use, after which the cell becomes exhausted through consumption of the zinc element, or the electrolyte, 2, from short circuits long continued, which cause the cell to run out of current more rapidly than otherwise, and 3, from neglect to open the switch or the primary circuit when stopping the engine.

A temporary short circuit will not injure a dry cell as seriously as it will some other types. Generally, it will polarize more

quickly. A season on open circuit will find it still serviceable. If then, there be a leak, or the timer rotor be in engagement with one of the contacts, the current will rapidly run to waste.

Ques. What is the action of dry cells?

Ans. Dry cells, so called, are all of the "open circuit" variety. That is to say, the generation of the current produces the condition known as "polarization," or the collection of hydrogen on the electrode attached to the positive lead wire. The cell may be "depolarized," by leaving it

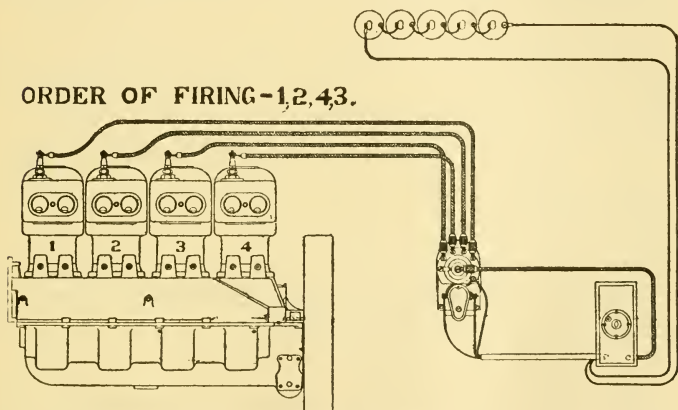

Fig. 154.—Wiring diagram showing connections for Remy magneto with separate coil and battery; the figure illustrates also the order of firing.

for a period on open circuit, or disconnected. A polarized cell will show a low current register on the ammeter, but its strength may be restored more or less.

Ques. What precautions should be taken with a storage battery?

Ans. Each cell should register at full charge about 2.5 volts and should never be used after the voltmeter falls to 1.75. If short circuited at any time, the cell should be immediately disconnected and recharged, as elsewhere specified. Short circuiting is one of the worst mishaps that can overtake a storage cell.

Ques. What is the effect of a weak battery?

Ans. It causes misfiring.

Misfiring caused by a weak battery is indicated by the occasional violence of the explosions, on account of frequent misses. A weak battery will cause misfiring, especially when the engine has been run nearly to full speed, and then suddenly stops, owing to irregular ignitions. The reason is, that the weak battery cannot supply "fat" sparks at a rate commensurate with the requirements of rapid operation. With a reduced spark gap and a slow speed, the battery may be able to cause operation for a limited period.

Ques. How may the action of a weak battery be improved?

Ans. By reducing the gap between the spark plug points.

Ques. What are frequent sources of trouble with a generator?

Ans. Glazing, faulty brush adjustment and defective governor action.

Ques. What is glazing?

Ans. A very fine deposit of metal particles on the commutator, due to the wear of the brushes.

Ques. How is this removed?

Ans. The deposit on the brushes may be removed by wrapping a very fine **sandpaper**, sand side up, around the commutator and rotating the spindle so that the brush ends are thoroughly scoured. It may be removed from the commutator by rubbing its surface with the finest grade of sandpaper. Emery paper should not be used for this purpose, since emery, being carbon, is a conductor, and its presence between the segments of the commutator is liable to interfere with the insulation. It also causes extra wear.

Ques. What is the nature of the primary current?

Ans. It is of low pressure, hence, its flow is easily prevented by loose and corroded terminals, defective switches or breaks of any kind in the continuity of the wire.

Ques. What precaution should be taken with the primary circuit?

Ans. On account of the low voltage: 1, the terminals should be kept clean and bright, 2, the connections firmly made, 3, the spring portions of the switches adjusted so that they bear firmly, making a good contact, 4, frequent examinations for partial breaks, and 5, the insulation guarded against breaks, flaws, or rubbed areas.

Ques. What defect in the primary circuit may cause misfiring?

Ans. Loose connections of the wires at a binding screw.

The looseness may be small, or it may be excessive, and the condition in this respect determines the degree of interference in engine operation. Thus, a loose connection may allow the engine to run from rest to a moderately good speed before trouble begins; sometimes the vibration of operation may interrupt the contact entirely.

Ques. What are common causes of misfiring at high speeds?

Ans. Loose circuit connections, shaken out of position as the engine speeds up, and weakened battery.

Ques. What attention should be given to the timing device?

Ans. It should be examined occasionally for loose contacts, thick oil or dirt on the contact surface.

Loose or foul contacts constitute a fertile source of ignition failures.

Ques. What kind of oil should be used on wipe contacts?

Ans. Only the thinnest and lightest grade of oil; it should be applied in small quantities.

Ques. What effect has the speed of the engine on ignition?

Ans. The spark in the cylinder does not occur at the same point in the piston stroke at high as it does at low speeds, nor at the moment the primary circuit is made by the timer.

Ques. Why is this?

Ans. It is due partly to the vibrator and partly to the coil. In producing a spark, time is required to saturate the coil, make the break, and discharge the core.

The average duration of these operations is about .005 of a second, which, although quite negligible at low speeds, requires progressive advances of the timer as speed increases. The movement of the vibrator also consumes a fraction of a second, its speed being indicated by the pitch of its buzz, but unless the speed be very high, the time for occurrence of the spark is changed. If the vibrator be leaving the core at the moment of circuit making at the contact maker, the time of one vibration must elapse before the occurrence of the spark; if the vibrator be in contact at this moment, the spark follows almost immediately. These facts enforce the desirability of high speed vibration.

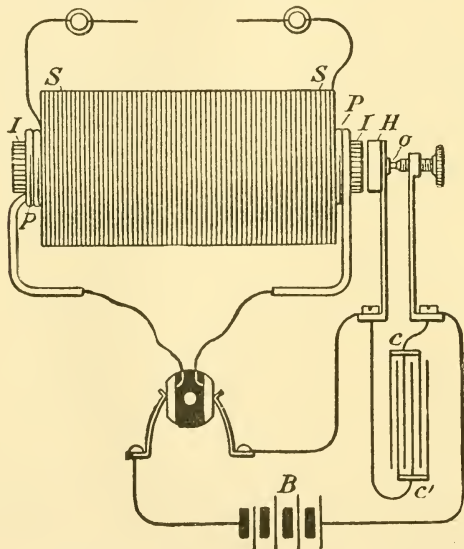

Fig. 155.—Diagram of the essential parts of an induction coil: B, chemical battery; C, C', condenser terminals; I, laminated iron core; P, primary winding; S, secondary winding; H, head of the vibrator; O, contact point of the back stop screw.

Ques. How should the vibrators of a multi-unit coil be adjusted?

Ans. In a multiple engine using a separate coil for each cylinder, the vibrators should be tuned as nearly as possible to the same rate of vibration; otherwise the sparks will occur at different points of the several respective piston strokes.

Ques. What may be said about vibrator adjustment?

Ans. In most cases the vibrator requires no adjustment. However, in making adjustments it should be noted that: 1, when the adjusting or back stop screw is turned inward forcing the vibrator nearer to the pole of the core, the rapidity of vibration will be increased, 2, when the adjustable screw is turned outward, increasing the distance between the vibrator and pole of the core, the rate of vibration will be decreased, 3, there are very definite limits for the proper operation of the core, at either loose or tight adjustment, 4, a fair adjustment for low speeds may prove unsuitable for high speeds, and *vice versa*, 5, a fair adjustment for a strong battery will probably be found unsuitable for a weak battery, and *vice versa*; therefore, the battery should receive attention, rather than the coil adjustment.

Ques. State briefly some general rules for vibrator adjustment?

Ans. In adjusting a coil: 1, the vibrator should vibrate with sufficient rapidity to give a distinctly musical sound, 2, rapid vibration, except, of course, that which is excessive, is more efficient and better for the battery than one that is slower, and 3, reducing the rate of vibration increases the efficiency of a weak battery.

The explanation of the matter is, that reducing the rate of vibration produces a stronger spark by permitting the coil to saturate more freely.

Ques. What sort of vibrator adjustment will cause misfiring at high speeds?

Ans. A faulty adjustment giving extremely short **makes** of the primary circuit and slow rates of vibration, which cannot keep pace to the requirements of high engine speeds.

Ques. How are the vibrator contacts sometimes burned?

Ans. Occasionally a spark discharged from the condenser occurs at the moment of breaking contact of the

vibrator and screw back stop, with the result of burning the contacts. Dirt or oil between the vibrator points will produce a similar result. In either case, there will be no spark at the spark plug.

Ques. What causes a spark discharge at the vibrator contacts?

Ans. This usually results from the condenser not being suited to the battery. When the condenser is of proper size, there will be little or no spark.

Ques. What is the action of a defective coil?

Ans. A broken down coil, or one in which the insulation is weakened, will cause misfiring for a time, and will soon be of no use.

Ques. What does a constant sounding of the vibrator indicate?

Ans. A leak or short circuit, which should be immediately investigated.

A short circuit is the quickest means for exhausting a primary battery. On the other hand, it causes speedy destruction, as will be explained later.

Ques. What causes defects in the interior of the coil?

Ans. They are usually caused by the presence of moisture, oil or dirt, and by the condenser not being suited to the battery.

The coil generally needs very little attention. There is virtually little danger of electrical derangement, provided the battery be maintained at approximately even efficiency, and the coil is protected from moisture, oil and dirt. It may be safely asserted that the majority of cases in which the coil is supposed to be "worn out," are merely examples of irregular or inefficient action of the condenser.

Ques. What effect has moisture on a coil?

Ans. Nothing will so rapidly deteriorate a high tension coil as the presence of moisture in its windings.

The water frequently soaks through the insulation, short circuiting the current and preventing a spark. A coil affected by moisture, cannot be repaired, except by experienced workmen, and had best be replaced.

Ques. What precaution should be taken in purchasing a coil?

Ans. It is necessary to ascertain that the coil is suitable for the type of battery or generator in use. Induction coils, like other electric coils, are wound for use with a certain definite voltage in the primary circuit.

Ques. What ignition defect sometimes causes misfiring?

Ans. A short circuit, that is, a ground, or an arcing gap between the two sides of the secondary circuit, at some point short of the plug terminals. This will, of course, prevent sparking at the plug, although, owing to the vibration of operation in the other cylinders, the short circuit may occasionally be interrupted and the spark will again occur.

Ques. How does a short circuit differ from an auxiliary spark gap?

Ans. It differs in that the gap is in series with the spark plug, while the short circuit gives a leak in parallel to it.

Ques. State two causes for failure of the vibrator.

Ans. A defective adjustment of the vibrator which will prevent it responding to the strength of the current in use, or the vibrator may be broken loose.

Ques. How may a defective spark plug sometimes be located in a multi-cylinder engine?

Ans. By touch, that is, if its cylinder has been "missing" for some time, the metal of the plug will be perceptibly cooler than that of the other plugs.

Ques. What defect is sometimes present in the secondary wiring?

Ans. Faulty insulation. The current, on this account, may short circuit to some metallic portion of the car or engine. If the secondary lead be disconnected from the spark plug, the current may sometimes be heard or seen in discharging.

Ques. What defects in the spark plug will cause failure to start?

Ans. The engine will not start when: 1, the plug points are too far apart, 2, the plug is short circuited, 3, the insulating layer of porcelain or mica is broken down, and 4, there is much fouling between the plug points.

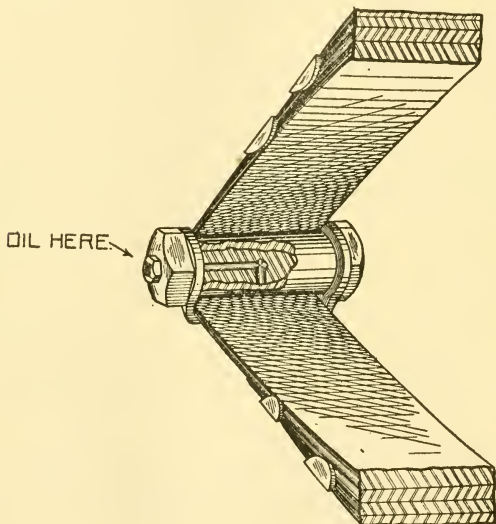

Fig. 156.—An important though much neglected place for lubrication.

Ques. What causes fouling?

Ans. Oil or soot; both give trouble in starting.

Ques. How may soot be removed?

Ans. By the application of gasoline.

Ques. What devices are used to prevent fouling?

Ans. An annular space between the core insulation and the outer shell; also an auxiliary spark gap. The best method of preventing fouling is by the proper handling of the fuel and cylinder oil.

In the former, a vortex is formed, whose whirling motion allows the piston suction to remove deposits of soot. An auxiliary spark

gap does not prevent fouling, but allows the voltage of the secondary current to rise sufficiently to suddenly overcome the resistance of the auxiliary gap and also that of the plug.

Ques. How can fouling be removed?

Ans. Any visible fouling may be removed by rubbing the insulation with fine sand paper until the bright surface of the porcelain is visible, taking care not to impair the surface.

Ques. If no fouling be visible in a defective spark plug, what should be done?

Ans. The plug should be laid upon the cylinder or frame, so that its case only is in contact, and thus grounded; on cranking the engine, the spark may be seen leaping between the points.

If there be no spark, it is probable that, with the ignition circuit in working order, there is some breakage or short circuit in the body of the plug. This, of course, necessitates its removal and the substitution of a new one.

Answers Relating to Engine Operation During Cold Weather

Ques. What effect has cold weather on the operation of an engine?

Ans. Sometimes gas engines work indifferently in cold weather; a low temperature interferes with effective engine performance in several ways: 1, it renders difficult a rapid vaporization of the fuel, 2, it causes the lubricating oil to thicken and in some cases to become "gummy," 3, it causes freezing of the jacket water, unless precautions be taken to prevent it.

Ques. What is the principal source of failure to operate in cold weather?

Ans. The uncertainty regarding good vaporization of the fuel in the carburetter.

It is obviously impracticable to heat the ordinary variety of carburetter except by arranging the air feed pipe to run over or around the muffler, which would doubtless assist matters considerably after the engine is started.

Ques. What should be done in case of sticking, from gummed oil in cold weather?

Ans. A small quantity of gasoline should be applied over the piston with a syringe.

Ques. What damage is liable to happen in cold weather?

Ans. The freezing of the cooling water in the jackets. A frozen water jacket generally bursts, without, however, doing injury to the arched walls of the cylinder. The engine may be started, but it soon overheats because the jacket water leaks through the cracks.

Ques. What precautions should be taken to prevent freezing?

Ans. In cold weather a careful operator will drain all water from the jackets and circulating system, by opening the pet cocks on the cylinder jacket, the pump, feed pipes and the radiator. After the water has run out, the jackets and pipes can be dried by allowing the engine to run for not over a minute, thus vaporizing and expelling the remaining moisture.

Ques. What should be done if an automobile is to be run in cold weather, especially if it is to be left standing with the engine not operating?

Ans. When the first freezing weather appears, care should be exercised to prevent the freezing of the circulating water.

If water be allowed to stand in the radiator the car should be kept in a room in which the temperature is not lower than 40 degrees. If this be impossible, the entire system should be drained by opening the pet cock in the water pump trap. After allowing the water to drain, the engine should be started and run for a minute or two, to further remove the water. An anti-freezing cooling medium may be used, in which case the best solution is a mixture of alcohol, glycerine, and water. Equal parts by weight of alcohol and glycerine to varying amounts of water has been found quite satisfactory.

The following tables are appended as an aid to arriving at the best solution:

5%	alcohol and glycerine to 95%	water by weight	freezes at 28°	Fahr. (Above zero).
10%	" " " "	" 90%	" " " "	" 25° " " "
15%	" " " "	" 85%	" " " "	" 20° " " "
20%	" " " "	" 80%	" " " "	" 15° " " "
25%	" " " "	" 75%	" " " "	" 8° " " "
30%	" " " "	" 70%	" " " "	" 10° " Below "
33 $\frac{1}{3}$ %	" " " "	" 66 $\frac{1}{2}$ %	" " " "	" 15° " " "

To prepare enough solution to fill the radiator, one of the following formulas may be used:

1 $\frac{1}{4}$	pints alcohol.....	}	freezes at 28° Fahr. (above zero.)
3 $\frac{3}{4}$	pint glycerine.....		
30	pints water.....		
2	pints alcohol.....	}	freezes at 25° Fahr. " "
1	pint glycerine.....		
29	pints water.....		
3	pints alcohol.....	}	freezes at 20° Fahr. " "
1 $\frac{1}{2}$	pints glycerine.....		
27 $\frac{1}{2}$	pints water.....		
4	pints alcohol.....	}	freezes at 15° Fahr. " "
2	pints glycerine.....		
26	pints water.....		
5 $\frac{1}{2}$	pints alcohol.....	}	freezes at 8° Fahr. " "
2 $\frac{1}{2}$	pints glycerine.....		
24	pints water.....		
7 $\frac{1}{2}$	pints alcohol.....	}	freezes at 10° Fahr. (below zero.)
3 $\frac{1}{2}$	pints glycerine.....		
21	pints water.....		
8	pints alcohol.....	}	freezes at 15° Fahr. " "
5	pints glycerine.....		
19	pints water.....		

The proper solution should be determined by local conditions rather than by rule.

The use of glycerine is detrimental to the rubber hose connections, but as this is really of small consequence in comparison with the risk incurred by using water, the expense is negligible.

The following solutions are also recommended:

A solution of equal parts by weight of water and wood alcohol.

A solution of two parts of wood alcohol, 1 part glycerine, 1 part water.

Ques. What are the objections to anti-freezing solutions?

Ans. They are troublesome, and at best, do not cool as well as pure water. On this account many users find it more satisfactory to drain the jackets through the pet cock on the radiator, when the car is to stand over night, and refill the cooling system before the next start.

CLUTCHES

Every vehicle propelled by a gas engine requires some form of throw out clutch, because it would be difficult to start the engine with the driving gear connected. The subject of the clutch is of importance because the efficiency of the car depends largely upon its proper design and handling. The principles and construction of the clutch system on any given car should, therefore, be understood by the operator.

Answers Relating to Clutches

Ques. What is a clutch?

Ans. A movable friction coupling for connecting the crank shaft to the transmission shaft. It is so arranged that the latter may remain stationary with the former in motion until "thrown in," whereupon the transmission shaft will turn with the crank shaft.

Ques. What are the requirements of a good clutch?

Ans. The leading requirements are: 1, gradual engagement, 2, quick disengagement, 3, large friction surfaces, 4, accessibility, and 5, simple construction.

Ques. What may be said of the first requirement?

Ans. The action should be such that it does not apply the full power of the engine at once, but gradually, in

order that the automobile may start slowly and without jerking. If the power be applied suddenly, the machinery may be badly strained, or again, the resistance of the stationary car may be sufficient to overcome the momentum of the engine and cause it to stop between the power strokes.

A clutch is not necessary on automobiles propelled by steam or electricity, as these powers are more flexible, that is, the application of power is not intermittent, as with the gas engine.

Ques. Why should a clutch disengage promptly?

Ans. This is desirable in order to avoid any drag of the parts after disengagement.

Ques. Why are large friction surfaces necessary?

Ans. In order that the clutch may be capable of transmitting the maximum power of the engine to which it is applied without slip or loss. This is to avoid a waste of power, and also render the clutch easy to operate.

Ques. How should a clutch be made?

Ans. A clutch should be easy of removal for inspection or repairs, and should be provided with suitable adjustments so that a certain amount of wear between the surfaces may be taken up without renewal of surfacing. It should be as simple as possible, of substantial design and construction, and with as few operating parts, which would be liable to get out of order, as is consistent to preserve proper operation. In event of the parts needing replacement, or of wear being serious enough to require new frictional surfaces, it should be of such construction that the replacement could be made with minimum expense.

Ques. Describe a cone clutch?

Ans. As shown in figs. 157 and 158, a cone clutch consists of two members: a dish-shaped ring, secured to the face of the fly wheel, and a truncated cone carried by a sleeve

sliding on the main shaft, and held in close fit by means of a spring. The first member is called the "female cone" and the second the "male cone."

Ques. Name two varieties of cone clutch.

Ans. 1. The external cone clutch shown in fig. 157, in which the male cone is forced against the fly wheel

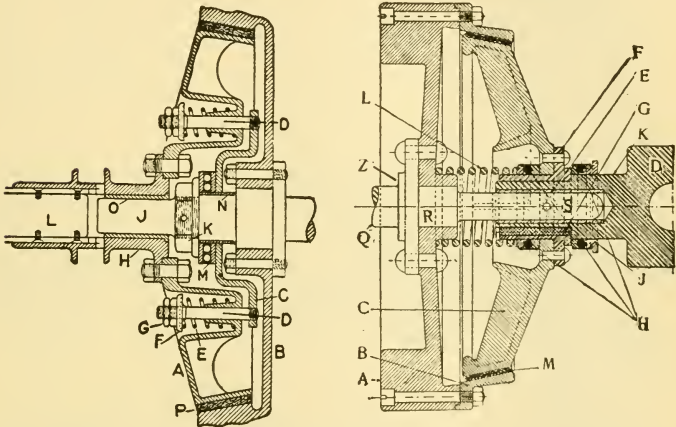

Fig. 157.—External cone clutch. A, fly wheel clutch cone; B, fly wheel; C, fly wheel clutch stud plate; D, D, clutch spring studs; E, clutch spring; F, spring retainer; G, retainer lock nut; H, sliding sleeve for setting clutch; J, crank shaft end; K, crank shaft nut; L, tail shaft; M, ball thrust collar; N, ball thrust bush; O, sliding sleeve bush; P, clutch cone leather.

Fig. 158.—Internal cone clutch. A, Engine fly wheel; B, female cone; C, male cone; D, universal coupling on male cone; E, bushing on D; F, collar keyed on D; G, key; H, ball bearings for taking up the thrust on disengaging clutch; J, flange on ball cone; K, receptacle on D for operating yoke; L, spiral spring for retaining clutch surface contact; M, leather band riveted on C giving good friction surface; Q, main shaft; R, portion of shaft turned down to fit fly wheel; S, portion of shaft turned down to receive clutch sleeve; Z, flange to which fly wheel is bolted.

from the rear, and 2, the internal cone clutch, fig. 158, in which the male cone is contained within the other member, and is forced into contact from the front.

In both forms, the contact is between a metal surface and one of leather or fibre. Since it is essential that no oil or grit be allowed to collect on the friction surfaces, the internal cone clutch is preferable, as enabling the surface to be more readily protected.

Ques. What two things are essential in order to obtain good power transmission by means of a clutch?

Ans. Sufficient friction surface, and the proper angle of the cone surface.

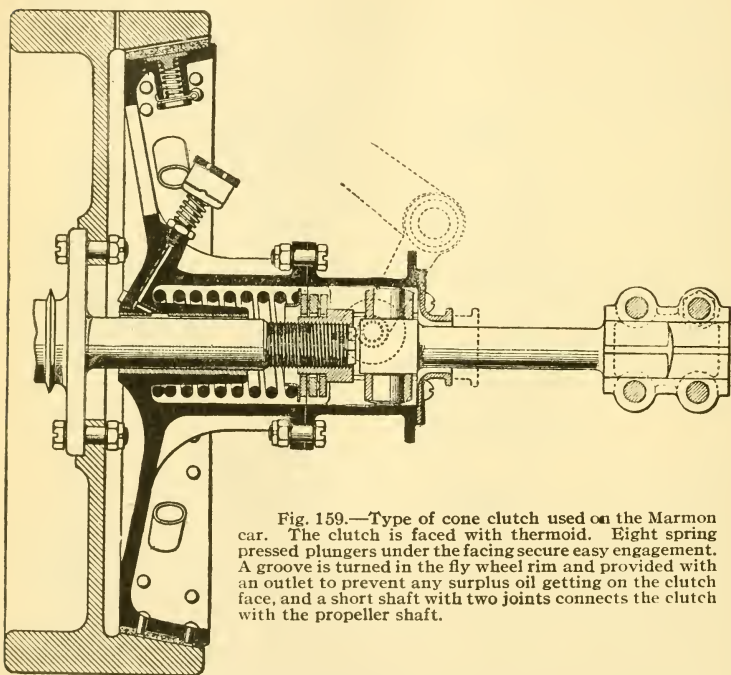

Fig. 159.—Type of cone clutch used on the Marmon car. The clutch is faced with thermoid. Eight spring pressed plungers under the facing secure easy engagement. A groove is turned in the fly wheel rim and provided with an outlet to prevent any surplus oil getting on the clutch face, and a short shaft with two joints connects the clutch with the propeller shaft.

Ques. What is the usual angularity of the friction surface?

Ans. Between 12° and 15° , generally nearer the latter which affords a friction surface in breadth about one-eighth the fly wheel diameter.

Ques. What troubles are sometimes encountered with cone clutches?

Ans. Unless skillfully handled, the power will be thrown on with a jerk, — not gradually as it should be. The friction surfaces, when worn, are liable to slip.

Ques. What has been done to avoid the first difficulty?

Ans. Some designers place small spiral springs on the surface of the male cone, or between the cones, thus rendering the grip between the surfaces gradual. Such springs may act efficiently, but are objectionable in that they complicate the construction.

Ques. Describe a drum and band clutch.

Ans. This form of clutch is simply a variation of the type of brakes most common on automobiles.

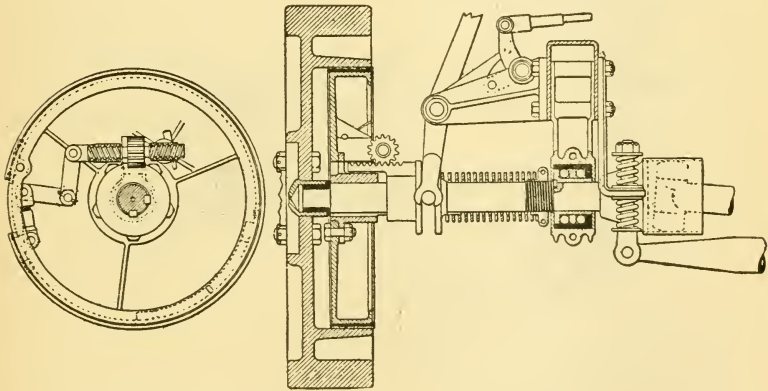

Fig. 160.—End view and cross section through an expanding ring clutch.

Drum and band clutches are generally used in connection with planetary or epicyclic transmissions, and consist simply of leather or fibre rings, which are compressed against the circumference of the drums, to prevent rotation.

Ques. Describe an expanding ring clutch.

Ans. Mechanically, this type of clutch is identical with the expanding ring brake, except for the fact that its use accomplishes the connection into a working unit of two turning shafts.

The general construction is shown in fig. 160. The friction surfaces of the ring clutch may be both of metal or the ring may be faced with fibre.

Ques. What is a multiple disc clutch?

Ans. This consists of numerous metal discs secured alternately to the clutch shaft and to the face of the engine

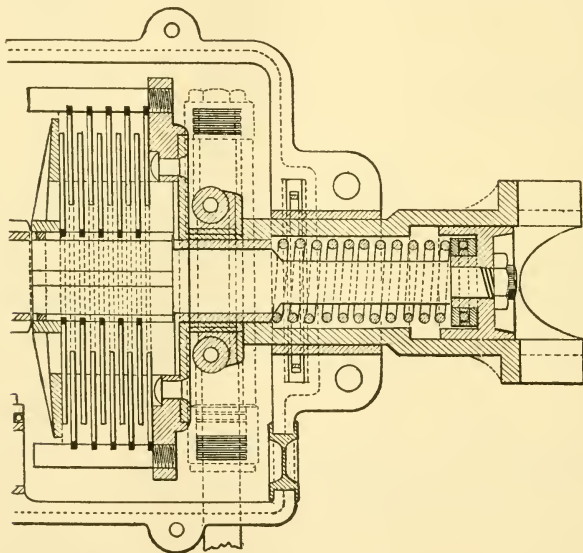

Fig. 161.—Multiple disc clutch; sectional view showing construction.

fly wheel, as shown in fig. 161. The discs are compressed in frictional contact by a strong spring, thus giving a firm driving contact for transmitting the power from the engine to the transmission.

Ques. What advantage has a multiple disc clutch over one with only a single pair of friction surfaces?

Ans. If only one pair be used, the necessary pressure between the rubbing surfaces is much greater than when a

number of surfaces are provided. Thus, if there be, say, twenty friction surfaces, the pressure required to hold the discs together without slipping would be only about one-twentieth of that necessary in the first instance.

Answers Relating to Clutch Operation

Ques. What two terms are used to describe the operation of a clutch?

Ans. A clutch is said to be "sweet" when it properly performs its functions, that is, when it may be thrown into engagement gradually, thus applying the power by degrees, so that the car may start slowly and without jerking. A clutch is said to be "fierce" when the reverse conditions obtain, that is, when it takes up its work too quickly, causing the car to jump forward with a bound upon starting.

Ques. What causes a clutch to be fierce?

Ans. This derangement is often caused by the clutch spring being too strong; this results in an unusual amount of power being applied to the clutch pedal in actuating the clutch, and it is apt to stick, preventing a quick withdrawal at a critical moment.

Ques. What are the remedies for a fierce clutch?

Ans. The tension of the clutch spring should be made less, the friction surfaces cleaned, and a small quantity of castor, or neats foot oil applied to them.

Ques. What troubles are sometimes experienced with multiple disc clutches?

Ans. These are subject to three varieties of derangement: 1, gripping, 2, spinning, and 3, slipping.

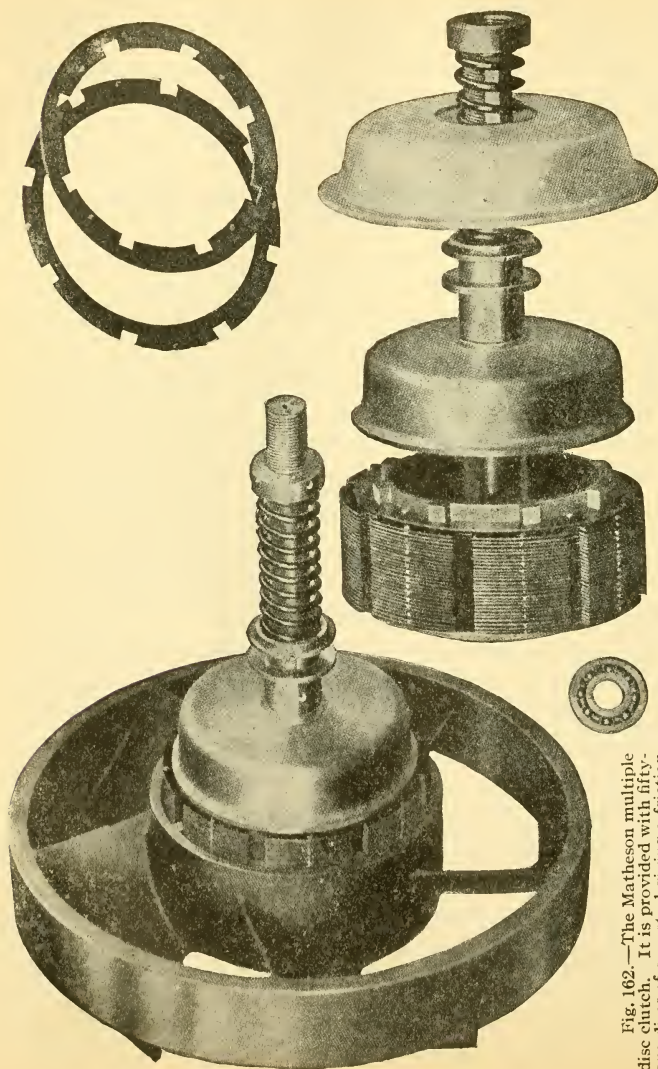

Fig. 162.—The Matheson multiple disc clutch. It is provided with fifty-one discs of saw steel giving a friction surface of approximately 1500 square inches. These discs are placed alternately, the next to the transmission shaft, etc., etc. When the clutch pedal is released, the tension of a coil spring presses the discs into engagement, but as these discs run in oil, the engagement is gradual and, therefore, the car starts smoothly and without any jerk.

that is, the first disc is attached to the transmission shaft, the next to the engine shaft, the discs are kept free from engagement by the four small lugs which are riveted through each disc. When the clutch pedal is released, the tension of a coil spring presses the discs into engagement, but as these discs run in oil, the engagement is gradual and, therefore, the car starts smoothly and without any jerk.

Ques. What is gripping, and how caused?

Ans. Gripping is a quick, sharp engagement of the clutch. It may be caused by looseness in the foot pedal or joints, or a "give" in the lever or fulcrum. A gradual clutch engagement cannot be secured when the leverage is not absolutely positive. Another cause is a too powerful spring tension. In a leather to metal contact, gripping may be caused by an exhausting of the oil in the leather, thereby roughening its surface.

Ques. How is gradual engagement secured with a multiple disc clutch?

Ans. A clutch of this type is encased and runs in oil, which prevents the rings gripping suddenly. When the pressure of the spring is applied, the oil is gradually squeezed out and the slipping of the driving and driver discs is thus reduced by degrees.

Ques. What causes "spinning?"

Ans. The continued revolution of the driven member is usually caused by faulty design, poor adjustment or failure to make a complete disengagement of the two members. This latter fault can be traced to improper lubrication, to an adjustment which does not allow sufficient movement to separate both members, or to an over tight clutch shaft bearing, causing binding between the members.

Ques. What causes slipping?

Ans. It is usually due to a spring tension that is too weak. Another cause is the undue wear of the friction surfaces, allowing the clutch pedal to move backward till it rests against the rear end of the slot in the floor.

Ques. What precaution should be taken with a leather friction surface?

Ans. Water or gasoline should not be allowed to come in contact with the leather, as either will dry up the oil that

keeps the leather in good condition. The oil may be dried out by frictional heat, hence, a careful inspection should be frequently made. A good leather dressing should be used when the leather begins to roughen. Machine oil should not be used, as it is not readily absorbed by the leather.

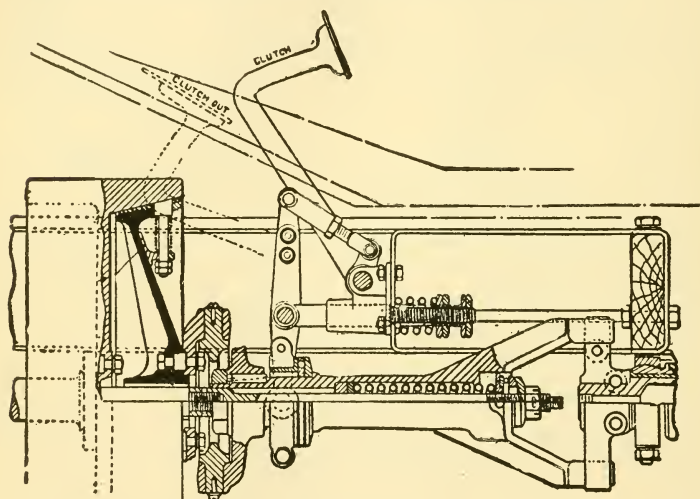

Fig. 163.—Showing method of mounting a cone clutch. The dotted outline of clutch pedal shows position for releasing the clutch.

Answers Relating to Cork Inserts

Ques. What material besides leather is sometimes used for friction surfaces of clutches?

Ans. Cork.

Ques. What are the properties of cork?

Ans. Cork forms a good friction surface for clutches. It will hold on a dry surface, or if the surface be lubricated, the

degree of polish is not a factor of such importance as would be the case with other materials.

Ques. What effect has high temperatures on cork?

Ans. High temperatures are not so liable to char cork, as they would leather or fibre.

Ques. Describe the method of inserting cork in a clutch and its action during operation?

Ans. Numerous cork discs are forced into suitable cavities formed for them in one of the metallic frictional

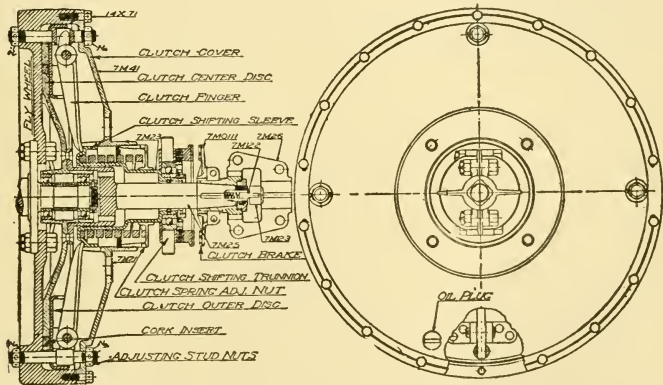

Fig. 164.—A three disc clutch with cork inserts. The cast iron fly wheel forms one of the clutch discs, the center disc being of manganese bronze and the outer disc of pressed steel. The clutch outer disc revolves with the fly wheel and the center disc with the main drive shaft, the first being normally pressed against the center disc, and that in turn against the fly wheel by the action of the clutch levers and the clutch spring. When it is desired to release the clutch, pressure is applied at the foot pedal and the clutch shifting lever is moved backward, removing the pressure of the spring from the clutch levers. This allows the clutch release spring to force the plates apart and release the clutch. At the same time the clutch brake becomes operative and brings the clutch disc and main drive shaft to rest.

surfaces. The corks are previously boiled and thereby softened and then pressed into the cavities. Thus established in a metal surface, they normally protrude above the surrounding surface and engage first when the surfaces are

brought together. If sufficient pressure be applied to the clutch they are forced down flush with the metal surface and act with it in carrying the load. Following the release of the load, they again protrude beyond the surrounding metal surface.

Ques. What forms of cork are used for "cork inserts"?

Ans. One form is cork in its natural condition, another form is prepared as follows: Small pieces of cork are compressed into sheets and blocks of any desired shape under great pressure and under enough heat to cause the natural gums of the cork to exude and act as a binder.

TRANSMISSIONS*

The term transmission has come to mean only that portion of the transmission gearing proper which lies between the engine shaft and the propeller shaft or driving chain; it does not include the rest of the driving gear, such as the clutch, bevel gear, jack shaft or differential. A better expression for this part of the driving mechanism is **change speed gears**, although the word transmission is generally used.

Answers Relating to Transmission Principles

Ques. Why is a transmission necessary?

Ans. On account of the nature of the gas engine cycle. The piston of a gas engine is operated by an intermittent force, and not, as in the case of a steam engine, by a continuous pressure, hence, it will only develop its full power when running at the maximum speed.

A four cycle gas engine receives only one impulse in two revolutions; it must give to the fly wheel during that impulse enough momentum to keep the engine going at approximately uniform speed during the exhaust, suction and compression strokes. In other words, the fly wheel must overcome by its momentum, for one and a half revolutions, the resistance of the load and also that due to the back pressure of exhaust, suction and compression.

*NOTE.—The term "transmission," strictly speaking, includes the entire mechanism between the engine and the rear wheels, through the several parts of which power is transmitted. The gear set is simply a part of the transmission, the drive another part, etc. However, by incorrect usage, the term has come to mean only the gear set.

Ques. How does the steam engine compare with the gas engine in regard to turning effect?

Ans. So far as the number of impulses per revolution is concerned, one steam engine cylinder is equivalent to four gas engine cylinders of the four cycle type, therefore, with the latter a heavy fly wheel is necessary in order to transform the highly varying and intermittent driving force into one nearer constant so that uniform rotation may be approached.

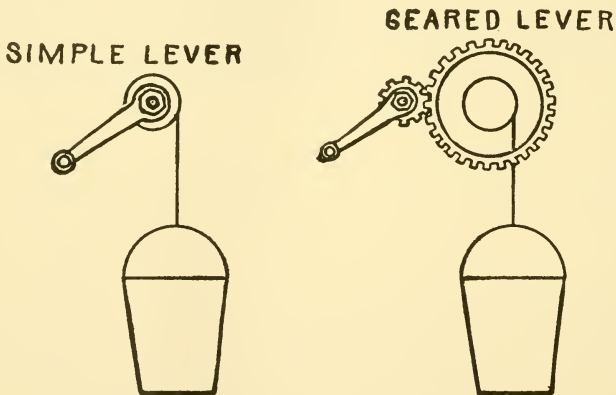

Figs. 165 and 166.—Diagrams illustrating transmission principles. A lever is shown in fig. 165, attached direct to a drum, and in fig. 166, gear wheels are shown placed between the lever and drum. If the force applied to the lever, be the same in each case, a heavier weight may be raised with the geared lever, because the force acts through a greater distance, the gear wheels multiplying the revolutions of the lever necessary to lift the weight a given distance.

Ques. What are the duties of a transmission?

Ans. The first object is to allow the engine to speed up until the energy which it stores in the fly wheel is sufficient to keep the shaft revolving at a speed showing no great percentage of variation. A second and principal duty is to adapt the engine to a heavy load, which, under other circumstances, would cause it to slow down and stall, if required to work under such conditions any length of time.

Ques. Explain by an example the necessity of a transmission to adapt the engine to a heavy load?

Ans. It may be assumed: 1, that a man is raising a bucket in a well by winding a rope around the drum of a windlass as shown in fig. 165, and 2, that the bucket must be raised a certain number of feet every minute; then if the bucket of water weigh such an amount as to require all his strength to fulfill these conditions, and that any extra weight added to the bucket would overtax his strength to such an extent as to make further progress impossible, it is evident that some mechanical contrivance is necessary which will enable him to exert the same strength, but apply it through a longer period of time.

To make this plain, it may be assumed that he wished to lift a barrel weighing 600 pounds ten feet. It is evident that this could not be done in a direct manner. If, however, he should build an incline long enough, he would be able to roll it up, accomplishing the same work, but taking a longer time. Another way of doing it would be by the use of a lever.

Now, returning to the first illustration, instead of turning the drum of the windlass direct by hand, a gear may be placed on the end of the drum and constructed to mesh with a smaller gear attached to the lever, as shown in fig. 166.

To illustrate the principles involved, it may be assumed that the large gear on the drum is three times the diameter of the small gear. It will, therefore, require three revolutions of the small gear to one of the large gear, and the pressure exerted will be only one-third of that required if the crank were fastened to the drum direct, as shown in fig. 165. In either case, the work done is the same.

To compare this with the conditions of automobile operation, the work required to lift the bucket may be represented by the work required to drive the machine, and the man's effort, or force applied to the lever of the windlass, by the pressure exerted on the piston of the engine.

Ques. What is work?

Ans. Work is the product of two factors: **force** and **distance** through which the force acts.

Ques. What is the relation between these two?

Ans. For a given amount of work, force and distance are inversely proportional, that is, if the distance be increased, the force will be diminished a corresponding amount.

Ques. How does this apply to the transmission, in adapting the engine to a variable load?

Ans. The office of a transmission is to keep the first factor—**force**—within allowable limits, by permitting the second factor—**distance**—to vary in proper proportion.

Ques. How are these factors represented in the operation of the engine?

Ans. The factor **distance** is represented by the distance travelled by the piston during the power strokes, and **force**, by the pressure exerted on the piston during these strokes.

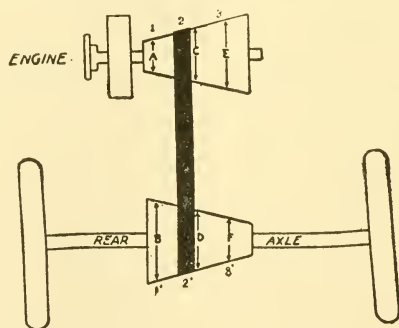

Fig. 167.—Conventional diagram illustrating transmission principles as applied to the automobile. A belt connects two cone pulleys one on the engine shaft and one on the rear axle. By shifting the belt to the right or left, the speed of the engine is respectively diminished or increased in relation to the speed of the rear axle.

Ques. Explain by an example the application of these principles to automobile operation?

Ans. Fig. 167 is a rudimentary diagram showing the working of a transmission. Two cone pulleys, one on the engine shaft and one on the rear axle are connected with a belt.* By shifting the belt to the right or left, the speed of the engine

* NOTE—In the early development of the automobile, a belt transmission somewhat similar to the one in fig. 167, was used in France, but was displaced later by a system of toothed gear wheels of various diameters to give the several speed ratios between the engine and rear axle, necessary to adapt the gas engine to the varied conditions of automobile propulsion.

is respectively diminished or increased in relation to the speed of the rear axle. Since for a given amount of work the two factors **force** and **distance** are inversely proportional, factor force may be kept within an allowable limit when a heavy load is put on the rear axle by shifting the belt to the left so that the speed of the engine is increased in relation to the speed of the rear axle, thus increasing the factor **distance**, and diminishing the factor **force**.

In other words, when a heavy load is put on the rear axle, the speed of the engine may be increased in relation to the speed of the rear axle, by shifting the belt to the left. This operation: 1, reduces the resistance to be overcome by the piston, and 2, stores up more energy in the fly wheel, both of which tend to keep the engine moving **during the three non-power strokes of the cycle**.

Ques. With a gear transmission, how does the operation differ from the belt?

Ans. Only a few speed changes can be made instead of any number, as is possible with the shifting belt.

Ques. How many speeds are usually provided with gears?

Ans. Three speeds forward and one reverse; however, a few cars have transmissions giving four speeds forward.

Ques. What is understood by low, intermediate, and high speed?

Ans. The terms relate to the movement of the car. Thus, in fig. 167, low speed would correspond to belt position 1, intermediate to position 2, and high speed to position 3.

Ques. What other names are given to these speeds?

Ans. First, second and third.

Ques. What name is given to high speed?

Ans. **Direct drive**, when the power is applied direct instead of being transmitted through the gears.

Ques. Name the several types of transmission?

Ans. The progressive, selective, planetary and frictional contact.

Answers Relating to "Progressive" Transmissions

Ques. What is the method of operating a progressive transmission?

Ans. With this type of transmission it is necessary, as its name indicates, to make the various speed changes in a definite order, that is, in passing from low to high speed, the intermediate speeds must be passed through in regular order.

Ques. Explain the arrangement and essential features of a three speed progressive transmission?

Ans. In the diagram fig. 168, power is applied from the engine at P and delivered at T to the driving shaft. The shaft T is squared for a portion of its length, and runs in a bearing inside of the gear C. The gears I and L₁ are cut out of the same piece of metal and fitted with a square hole so that they can slide along the shaft P, but not revolve independently of it. The gears C', I', and L'₁ are fastened rigidly to the countershaft CS, and therefore revolve with it. The gear R is an idler, but is so mounted that it may be shifted into mesh with L₁ and L'₁ when a reverse is desired.

Ques. How is low speed obtained?

Ans. If C and C' only be in mesh (fig. 168), and no power is being transmitted to the rear axle, then in order to obtain low speed, the gear combination IL₁ is shifted so that the gear L₁ will come into mesh with L'₁. The drive then, is through C, C', L'₁, L₁, and out through the shaft axle T from L'₁ and L₁.

Ques. Intermediate speed?

Ans. For the intermediate speed the gears are shifted so that I will come into mesh with I', L₁, of course, being

moved out of mesh with L' . The drive now is through C , C' , I' , I , and out through the shaft T to the rear axle.

Ques. Reverse?

Ans. To reverse, L and R are shifted so that L meshes with R , and R with L' . The drive, in this case, is through C , C' , L' , R , L , the introduction of the fifth gear causing a reverse direction of rotation of the rear axle.

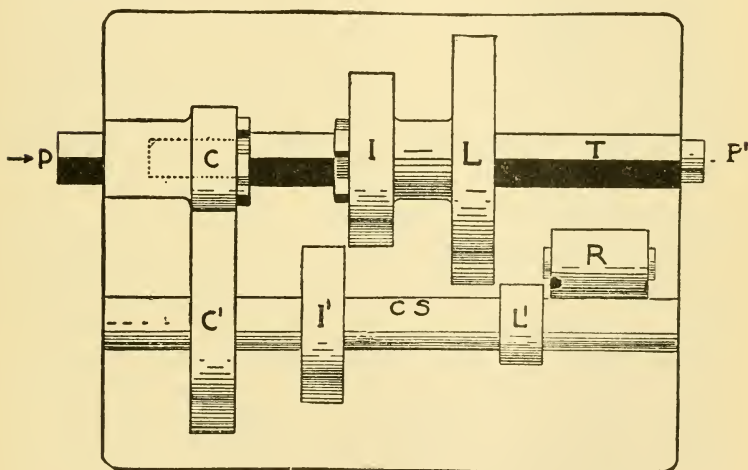

Fig. 168—Diagram of a three speed “progressive” transmission. The gears C' , I' and L' are fastened to the countershaft, while I and L slide on the square portion of the main shaft T ; R is an idler and is used for the reverse. The various speed changes are made by altering the position of the sliding members.

Ques. High speed?

Ans. For high speed, gears I and L are moved to the left so that they will be in mesh with no other gears, but a clutch cut into the left side of I will fit into the corresponding clutch in the gear C . This serves the purpose of coupling shaft T to shaft P , the drive then being “direct.”

Ques. What feature is characteristic of the progressive transmission?

Ans. The arrangement of the gears requires a longer shaft, larger case and bearings, than do the other types.

Answers Relating to "Selective" Transmissions

Ques. What advantage is gained with a selective transmission?

Ans. It permits the operator to throw in at will, any speed combination within the range of the transmission; thus it is not necessary in changing from low to high speed to pass through the intermediate speed as with the progressive system.

Ques. Describe the arrangement of gears of a three speed selective transmission?

Ans. As shown in the diagram fig. 169, this gearing consists of two parallel shafts, T and CS, the countershaft CS having keyed to it the gears C', I', L' and R', the latter a squared shaft T carrying the gears I and L. Gear G is an "idler" used for obtaining the reverse. P is a driving shaft directly connected with the engine through the clutch. Its gear C runs free on the shaft T, and is in mesh with gear C'.

Ques. Through what gears is power transmitted for low speed?

Ans. The drive, fig. 169, is from C to C' to L, through L'.

Ques. For intermediate speed?

Ans. L is thrown out, and I thrown into mesh with I'.

Ques. For high speed?

Ans. The claw clutch on I is slid into mesh with a corresponding clutch on C. The drive in this case is **direct**, going from P directly out through T, the gears C and I being locked by the clutch.

Ques. For reverse?

Ans. A fifth gear *G* is used for this purpose; to reverse *R'*, *G* and *L*, are placed in mesh. The drive then is through the gears *C*, *C'*, *R'*, *G*, and *L*.

Another three speed selective transmission is shown in figs. 170 to 173. This gearing consists of two parallel shafts, *I* and *S*, the former having keyed to it the gears *B*, *C*, *D* and *E*, the latter a

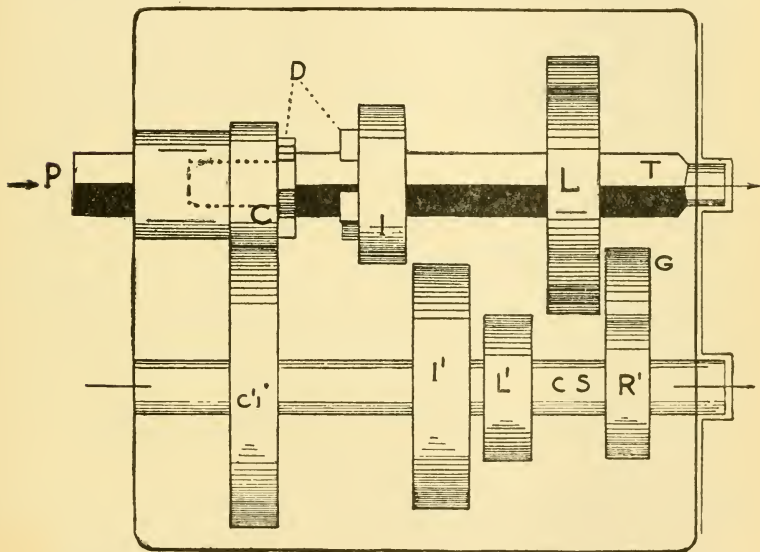

Fig. 169.—Diagram of a three speed "selective" transmission. With this system any of the several speed changes may be made at will without passing through the intermediate speeds as is necessary with a progressive transmission.

squared shaft for carrying the gears *H* and *F*. Gear *G* is an idler used for obtaining the reverse. *S* is the driving shaft directly connected to the engine through the clutch. *A* runs free on the shaft *S* and is in mesh with gear *B*.

Taking first the low speed position (fig. 170), the drive is from *F* to *D* to *A* through *B*.

On the intermediate speed (fig. 171), *F* is thrown out, and *H* is thrown into mesh with *C*.

For high speed (fig. 172), the gear *H* is slid into mesh with an internal gear cut into the rim of *A*. The drive in this case is

Ques. With a four speed transmission, which speed is direct drive?

Ans. Usually the fourth; in some cases the third.

Ques. Describe the speed changes for a four speed selective transmission.

Ans. A transmission of this type is illustrated in the diagram, fig. 174. For low speed, the drive is through C, C', G and D. The second speed through C, C', F and B. Third through C, C', E and A. The fourth speed, which, in this

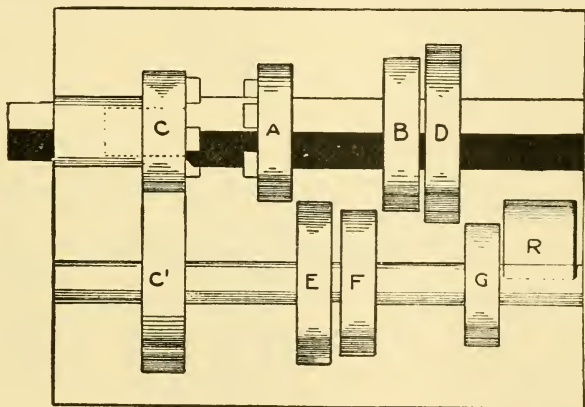

Fig. 174.—Diagram of a four speed selective transmission. This differs from the three speed only in the fact that four gears are used on the driving shaft instead of three.

case, is direct drive, is obtained by sliding the claw clutch A into engagement with C. For the reverse, the reverse gear R is thrown into mesh with G and D, making the drive through C, C', G, R and D.

Answers Relating to the Control Levers

Ques. How are the change speed gears shifted?

Ans. By a transmission or gear shifting lever attached to the side of the car next the driver. The lever is located

by the side of the emergency brake lever, and always on the inside, that is, the one nearest the driver.

Ques. What feature of design distinguishes the gear shifting lever from the brake lever?

Ans. Usually, the brake lever is provided with an external latch, while the transmission lever has a press button on top, the latch link passing down through the handle.

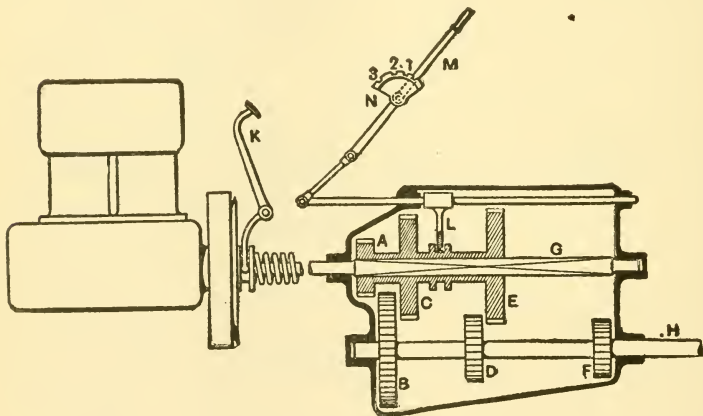

Fig. 175.—A transmission case with cover removed, showing gears in "neutral position." The parts are as follows: A, 1st speed sliding gear; B, 1st speed driven gear; C, 2d speed sliding gear; D, 2d speed driven gear; E, 3d speed sliding gear; F, 3d speed driven gear; G, square portion of driving shaft, carrying A, C and E; H, driven shaft, carrying B, D and F; K, clutch pedal; L, gear striking fork; M, change speed lever; N, change speed quadrant.

Ques. How is the lever connected with the change speed gears of a progressive transmission?

Ans. As shown in fig. 175, the lower end of the gear shifting lever is connected to a sliding rod which has attached a "finger" L. The latter engages with a groove on the sleeve of the sliding gears, C to move A and E, which are in turn meshed with the gears B, D, and F, giving respectively a first, second and third speed.

Ques. What is "neutral" position?

Ans. The position of the gear lever, as in fig. 175, which throws all the gear wheels out of mesh, and consequently, although the engine may revolve the shaft G, the power is not communicated to the shaft H.

Ques. Describe the gear shifting mechanism of a selective transmission?

Ans. This is illustrated by the diagram fig. 176. A is the gear shifting lever on the end of the shaft F, which is free

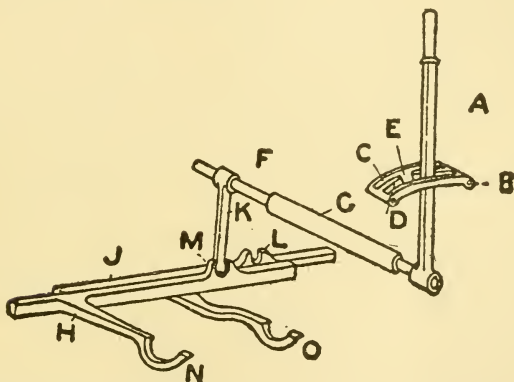

Fig. 176.—View of gear shifting lever, selector, and operating mechanism of a selective transmission. The parts are: A, gear shifting lever; C, D, slots in selector; E, gate; F, oscillating shaft; G, bearing for oscillating shaft; K, selector lever; M, L, selector lever slots; H, J, selector bars; N, O, fingers for shifting sliding gears.

to oscillate in sleeve G, or any bearing equivalent to the sleeve G, which is attached to some part of the car. It is also free to move endways inside the sleeve G. The extent of its oscillation in G is determined by the length of the slots in quadrant B, through which the lever passes. It will be seen that the quadrant B has two slots, C and D, with a gate E between them. Now the lever can only pass through from one slot to the other when it is in a position opposite to E, so that the combined width of the two slots determines

the distance of travel, of which the shaft F is capable inside the sleeve G. Attached at the other end of the shaft F, is a lever K, which not only moves with the oscillation of the shaft F, but is also moved endways with F. H and T are two bars which are free to slide endways in guides, which, for the sake of clearness, are not shown in the diagram. Projecting from the top slot of these bars are projecting slots with which the lever K can engage endwise so they may be moved lengthwise by any movement of the lever K. The bars H and J, have projecting fingers N and O, which engage with collars on the sliding gears.

Ques. Describe the operation of the mechanism.

Ans. If lever A of fig. 176 be moved to a position opposite the gate E, the sliding gears controlled by bar H, will be thrown out of engagement. When in this position, the slot M will come opposite slot L. If, now, the lever be pushed through the gate E into the slot C, lever K will similarly be pushed out of slot M into slot L; the operation of the lever A will now only control the bar T. That is, the lever has been made to select another bar in place of bar H.

Ques. How is "reverse" accomplished?

Ans. The reverse mechanism, for simplicity, is not shown in the figure, but consists of a third slot in a quadrant parallel with slots C and D, and has a gate similar to E, through which the hand lever can be pushed to engage with a third bar parallel to H and J.

It should be understood that the action of the gear shifting mechanism is such that the lever cannot be moved from one slot to the other without leaving the bar with which it formerly engaged, in the neutral position, and the wheels consequently out of gear.

Ques. What is the object of the press button on the transmission lever?

Ans. Simply a safety device to prevent the lever being accidentally thrown into reverse position.

Answers Relating to "Planetary" Transmissions

Ques. What is a planetary transmission?

Ans. One in which some of the gears are supported on pins or short shafts, which revolve around the main axis of the group. The same gears always remain in mesh with

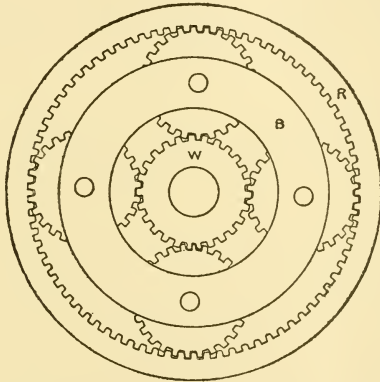

Fig. 177.—Diagram of planetary transmission. In operation, the band B which carries the four small planet wheels and which is attached to the propeller shaft is made to revolve slower than the engine shaft by the action of the planet wheels. These travel around the circumference of the central wheel, with which they are constantly in mesh. For slow speed; R is stationary; for high speed, B and R revolve with W; for reverse, B is stationary.

each other. Different sets are brought into action by stopping the rotation of one or the other of the parts which support the gears whose axes revolve around the main shaft. To stop the rotation of any part, it is gripped by a strap or band forming a part of the mechanism, and similar to a band brake.

Ques. Explain in detail the operation of a planetary transmission.

Ans. If in the diagram, fig. 177, the inner wheel W be driven by the engine shaft, and the rim R be fixed by a brake,

so that it cannot rotate, the band B, carrying the four small pinions, is forced to rotate bodily in the same direction as the inner wheel W, but at a much slower speed. The band B may be replaced by a circular plate, which is rigidly connected to the chain wheel, driving the road wheels of the car. When the brake shown is applied to the rim, the chain wheel rotates forward at slow speed.

Answers Relating to Frictional Contact Transmission

Ques. What is a frictional contact transmission?

Ans. A mode of transmitting power by contact of two plain revolving surfaces, usually in the form of friction discs.

Ques. What advantages does this system possess?

Ans. It obviates the difficulties incident to the use of sliding gear, or planetary transmissions, and also does away with clutches. Its chief advantage is that it permits an infinite number of variations in the speed ratio between the engine and rear wheels.

Ques. Describe one form of frictional contact transmission.

Ans. It consists of two elements, the driving friction disc and the driven friction disc. In the simplest form, the driven disc is set on a shaft at right angles to the driving disc, and is rotated by frictional contact between its edge and the face of the driver. When the edge of the driven disc is driven on a circle nearest the periphery of the driver, its speed is greatest. As it is slid along its shaft, toward the center of the driver, as may be done by means of a squared portion, its speed is constantly decreased. At the center of the driving disc it ceases to rotate. If slid beyond the center, its motion is reversed.

THE DRIVE

In the transmission of power to the driving wheels of an automobile, several methods are followed. These vary according to the size and weight of the vehicle and the character of the engine, also according to the individual preference of the designer. One system is preferred to another on account of real or supposed reliability, its efficiency in economizing power, etc.

Answers Relating to the Drive

Ques. What types of drive are in general use?

Ans. The shaft, the chain, and the spur drive.

Ques. Describe the shaft drive.

Ans. In this method, power is transmitted from the gear box to the rear axle by a propeller shaft, as shown in figs. 178 and 179. The engine is generally placed at right angles to the axle; it is therefore necessary to change the direction in which the power acts.

This involves the use of bevel gears at the rear axle. In addition, the following devices are required: 1, universal joints, 2, torsion rod, and 3, radius rods.

Ques. What is a universal joint?

Ans. A coupling for joining two shafts or parts of a machine endwise, so that the one may give rotary motion

to the other when forming an angle with it, or may move freely in all directions with respect to the other.

Ques. Why are universal joints necessary?

Ans. To allow the shaft to turn freely, even though it may not be in line with the shaft projecting from the gear box.

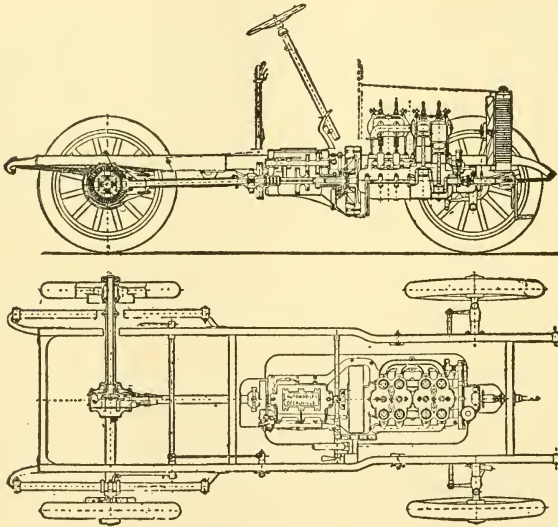

Figs. 178 and 179.—Sectional elevation and plan of the Decauville car, showing general arrangement of a propeller shaft drive through bevel gears to the rear axle.

It must be remembered that the engine and gear box are mounted on the frame, and that there are springs interposed between the frame and the axles, hence, when the latter vibrate up and down, the rear end of the propeller shaft moves in a circular path, with the forward universal joint as a center.

Ques. Name two types of shaft drive.

Ans. One in which the propeller shaft is placed at an angle with the other shaft sections, fig. 180, and one in which the several parts are in line, as in fig. 181.

Ques. What name is given to the latter?

Ans. The straight line drive.

Ques. What are its advantages?

Ans. It reduces friction and wear due to the angularity at the universal joints.

Ques. What is the construction of the straight line drive?

Ans. It is such that when the car is loaded, the propeller shaft is in direct line with the crank shaft. Under these

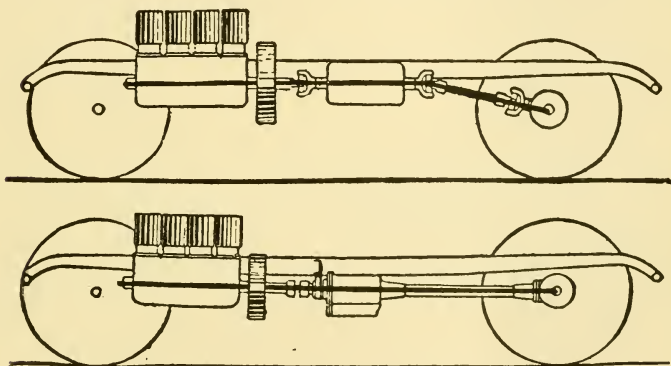

Figs. 180 and 181.—Diagrams to illustrate different constructions of shaft drive. The upper figure shows the ordinary construction, in which the rear shaft length is at an angle with the engine shaft. The lower figure illustrates the "straight line drive" in which the several shaft lengths are placed in a straight line, thus eliminating friction and wear due to angularity at the universal joints.

conditions, the drive is accomplished in a straight line which assures the delivery of the full power of the engine to the rear axle. On account of the action of the supporting springs, a universal joint is necessary, as the shaft sections are not in line when the car is light.

Ques. What is a torsion rod?

Ans. A rod attached rigidly to the housing or casing of the rear axle and fastened to a cross piece on the frame near

the transmission. Its object is to prevent the turning of the housing due to the thrust of the driving bevel.

Ques. What is a radius rod?

Ans. A device designed to prevent any forward or aft movement of the rear axle, which on account of the flexible action of the springs, may be caused by an obstruction in the road. Thus, if one wheel should strike heavy sand while its mate is on good surface, the rear axle will be thrown out of line with the drive and bring undue strains on the latter. To prevent this, radius rods are attached to the axle near the ends and pivoted at some convenient place on the frame. The axle, while free to rise and fall, is held at right angles to the drive.

Ques. What two types of chain drive are in general use?

Ans. The single and the double. In the first method there is a chain and sprocket connection from the main shaft direct to the differential on the rear axle. A double chain drive has a separate chain for each rear wheel, driven from a transverse jack shaft, which, in turn, is driven direct from the engine, and carrying the differential.

Ques. Describe in detail the double chain drive.

Ans. This construction is found on practically all heavy cars using chain drive. Briefly, the system includes, as shown in figs. 187 and 188: 1, a transverse center divided jack shaft driven direct from the engine, or through the transmission gear, by bevels to the differential, 2, a sprocket at each end of the jack shaft for providing chain connection to the hub of each rear wheel, and 3, driven wheels turning loose at the ends of a dead axle tree, each being driven by a separate chain on a sprocket secured to its hub.

Ques. What are the disadvantages of the chain drive?

Ans. Principally the chain, which is an objectionable mode of power transmission, especially under conditions of

automobile operation. There is the additional complication of jack shaft, sprockets, etc., involving much extra friction and wear.

Ques. Why is a chain objectionable?

Ans. Its use is accompanied by noise, excessive wear, imperfect engagement with the sprocket teeth and poor efficiency due to inherent defects and conditions of service.

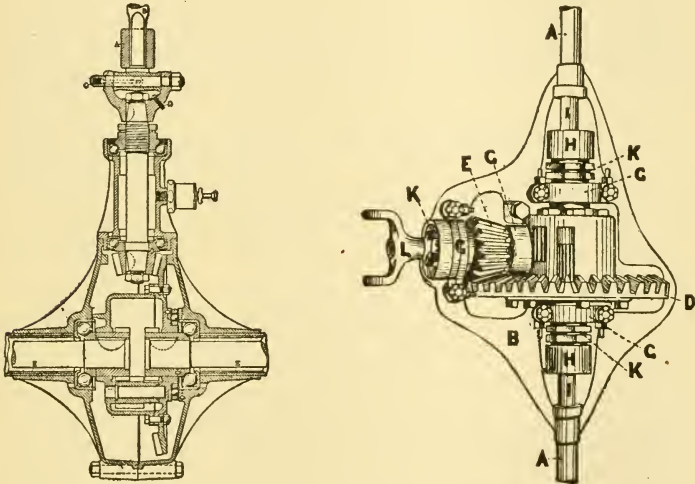

Fig. 182.—Sectional diagram of bevel gears for a shaft drive, showing arrangement of the propeller shaft and location of the thrust bearings.

Fig. 183.—Arrangement of bevel gear for shaft drive; A and B, sleeve and case for axles and gears; D, the driven gear; E, driving pinion; G, ball bearings on E, H; H, universal couplings on the differential; K, K, K, adjustments; L, yoke for flexible driving shaft.

M. O'Gorman, a prominent engineer, before the British Society of Arts has credited the shaft drive with 69 per cent. efficiency, and the chain drive with two chains and a jack shaft with but 50 to 58 per cent. efficiency. The gradual displacement of chain drive by the shaft drive is evidence of the superiority of the latter.

Ques. Under what conditions should a chain operate?

Ans. It should work in oil, in a dust tight case.

Ques. What is the advantage of the chain drive?

Ans. The greater portion of the weight of the drive mechanism is supported by the frame instead of the rear axle housing; it is thus cushioned from shocks due to uneven road.

Ques. What two kinds of chain are used?

Ans. Block chain and roller chain.

Ques. Describe a block chain.

Ans. A block chain is made of a series of blocks, properly shaped to fit the teeth of the sprocket, each joined to similar

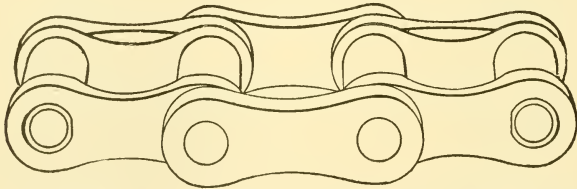

Fig. 184.—Section of a driving chain, showing arrangement of the rollers and side links.

blocks before and after by side links bolted through the body of the block.

Ques. Describe a roller chain.

Ans. A roller chain is composed of a series of rollers, known as center blocks, joined by side links. Each roller rotates loose on a hollow core which is turned to smaller diameter at either end, to fit a perforated side piece joining the rollers into pairs. The side links are set over these side pieces and bolted in place through the cores.

Ques. How do the two types compare in operation?

Ans. A block chain with generous slack is liable to meet the sprocket with a continual clapping, which at high speed,

becomes a rattle; the roller chain is largely free from this trouble.

Ques. Describe in general the operation of a chain.

Ans. The rivets of a chain act as a number of auxiliary shafts, and operate under friction in the same manner, but with less favorable conditions than the shaft that drives them. A chain can never be in true pitch with its sprocket. A pair of spur gears tend—to a certain extent—to wear into a good running fit with each other, but a chain, if made to fit its sprocket when new, does not continue to do so a moment after being made, as wear at once throws it out.

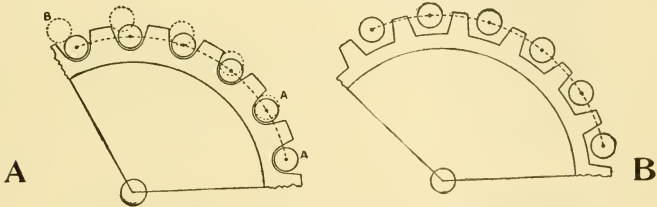

Figs. 185 and 186.—Diagrams showing the behavior of a chain on a sprocket of equal pitch, and on one of unequal pitch.

This being so, it must be put up with, and involves the consequence that a chain can only drive with one tooth at a time, supplemented by any frictional “bite” the other links may have on the base of the tooth interspaces. If the chain be made to fit these accurately, as in fig. 185 (taking a roller chain for illustration), it is obvious that the least stretch will cause the rollers at AA to begin to ride on the teeth as at B. If, however, the teeth be made narrow, compared with the spaces between the rollers, a considerable stretch may occur without this taking place. The roller interspaces, then, should be long, to permit the teeth to have some play in them, while retaining sufficient strength as shown in fig. 186, at B.

In order that the driving sprocket may receive each incoming link of the chain without its having to slide up the tooth face, it should be of a somewhat longer pitch than its chain, the result being that the bottom tooth takes the drive, this being permitted by the tooth play shown in fig. 186. This difference, of course, gradually disappears as the chain stretches. The back wheel sprocket, on the other hand, should take the drive with its topmost tooth, and hence should be of slightly less pitch than the chain, but as the pitch of the latter constantly increases, it may be originally of the same pitch. The only remaining point with regard to design, and one which the owner of the car may easily ensure, is that the number of teeth in the sprockets be prime to that of the links in the chain.

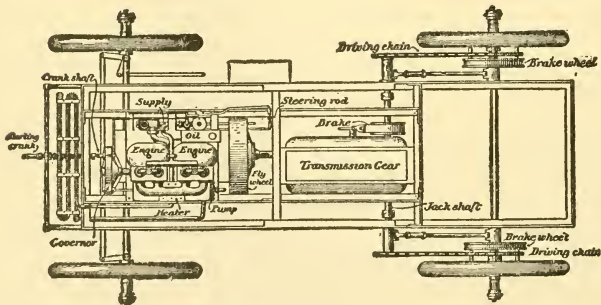
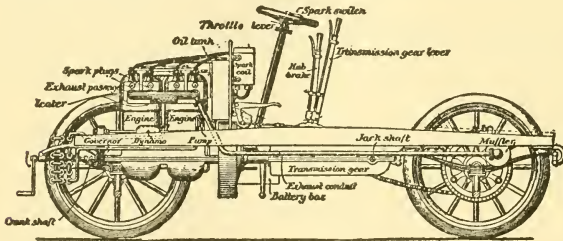

Figs. 187 and 188.—Elevation and plan of chassis, showing details of chain drive. The essential parts are: a jack shaft with differential, sprockets, and separate chain to each rear wheel.

Ques. What causes the snap and rattle of a chain?

Ans. The fact that even with the best designed sprocket, as each tooth in turn passes out of engagement with the chain, the next roller must be drawn forward through an appreciable distance before engaging a tooth. This action

not only produces the noise, but it is an important factor in waste of driving power.

Ques. What attention should chains receive to maintain a proper working condition?

Ans. The principal points to be observed in the use and care of sprocket driving chains are: 1, to maintain the proper tension in order to avoid "whipping"—which, particularly with a long one, is liable to result in snapping of the chain,—and, at best, involves a loss of driving efficiency. The chain should not be drawn too tight, lest a similar disaster result. Some slack must always be allowed, 2, two sprockets should always be kept in alignment. In the case of a double chain drive, from a counter shaft parallel to the rear axle, care should be exercised to maintain the parallelism, even preferring a somewhat loose chain to a tight one that strains the countershaft, 3, if a link show signs of elongation, it should be replaced by a new one, 4, whenever the chain is removed for cleaning or other purpose, it must be carefully replaced, so as to **run in the same direction** as formerly, and **with the same side up**. The chain should never be turned around, or its direction between the sprockets reversed, 5, a new chain should not be put on a much worn sprocket, 6, a chain should be frequently cleaned and rubbed with graphite, because the chief difficulty involved in the use of driving chains is the liability to clog and grind with sand, dust, and other abrasives, and 7, after steady use for a more or less extended period, the chain should be removed and cleaned throughout.

Ques. How may a chain be best cleaned?

Ans. After removing it from the sprockets, cleanse first in boiling water, then in gasoline, in order to remove all grease and dirt. The common practice is next to boil the chain for about half an hour in mutton tallow, which is

thereby permitted to penetrate all the chinks between rolling surfaces forming an excellent inside lubricant. After boiling, the chain is hung up until thoroughly cool, at which time the tallow is hardened. It may then be wiped off clean and treated with a preparation of graphite, or a graphite alcohol solution on its inner surface.

Some authorities recommend that the chain, after it is cleaned in boiling water and gasoline, should be soaked, first, in melted paraffin for an hour at least, and then in a mixture of melted mutton tallow and graphite. After each soaking, it is dried and wiped clean. With either process, a daily application of graphite is desirable.

Ques. Is it necessary that both chains be of equal tightness?

Ans. No; the differential gear on the jack shaft will counteract this and cause each chain to do its share of the driving.

Ques. What adjustment is important with a chain drive?

Ans. The jack shaft and rear axle should be made parallel by adjusting the radius rods to secure the proper engagement of the chain with the sprockets.

Ques. What may be said of the spur gear drive?

Ans. Transmission of power by spur gears, as from engine shaft to differential drum, or to an external or internal gear on each of the rear wheels, is, in some respects, very desirable. The drive between spurs is steadier, and is attended by smaller loss of power than between chains and sprockets, or bevels.

THE DIFFERENTIAL

When a car travels around a curved path, the distance travelled by the outside wheels is greater than that travelled by the inside wheels.

As the front wheels are loose on the axle, they can turn at different rates to compensate for this difference. Since both rear wheels are driven by the engine, it is necessary to apply a device that will permit them to rotate at different speeds, and receive an equal division of the power.

To accomplish this, a system of gears, called **the differential** is provided. The differential may be defined as a system of gears, which permits one wheel to travel independently of the other while going around a curve, so that the outer wheel may accommodate itself to the longer path it has to travel.

Answers Relating to the Differential

Ques. What two types of differential are in general use?

Ans. The bevel, and the spur differential.

Ques. Describe the bevel type of differential gear.

Ans. This is the original form, and is largely used. As shown in figs. 189 and 190, the sprocket or drive wheel has secured to its inner rim several studs carrying bevel pinions, which, in turn, engage a bevel gear wheel on either side of the

sprocket. These gear wheels, last mentioned, are rigidly attached on either side to the inner ends of the center divided axle bar, one serving to turn the left wheel, the other the right. When power is applied to the sprocket, causing the vehicle to move straight forward, it may be readily understood that the bevel pinions, secured to the sprocket, instead of rotating which would mean to turn the drive wheels in opposite directions, remain motionless, acting simply as a

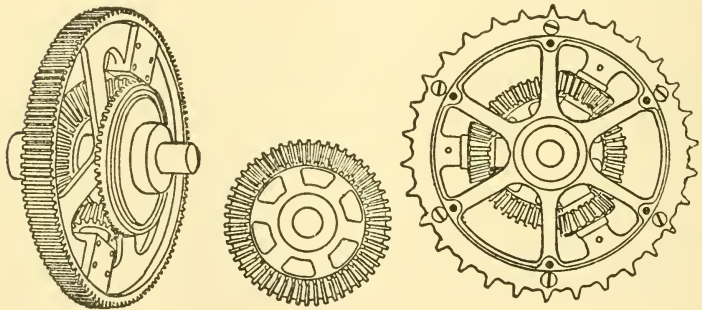

Figs. 189 and 190.—Bevel gear differential. The sprocket gear carries three bevel pinions set on studs on three of its radii. These pinions mesh with bevel wheels on either side, which wheels are attached at the two inner ends of the divided axle shaft.

kind of lock or clutch to secure uniform and continuous rotation of both wheels. So soon as a movement to turn the vehicle is made, at which time the wheels tend to move with different speeds, the resistance of the wheel nearer the center, on which the turn is made, tending to make it turn more slowly than the other, as may be observed, these pinions begin rotating on their own axes. Thus, while allowing the pivot wheel to slow up or remain stationary, as conditions may require, they continue to urge forward the other at the usual speed.

Ques. State the principles upon which the operation of the differential depends.

Ans. The principles involved may be expressed under four heads: 1, when the resistance offered by the two drive wheels and attached gear is the same, as when the car is driven forward, the pinions cannot rotate, 2, when the resistance is greater on one wheel than on the other, they will rotate correspondingly, although still moving forward with

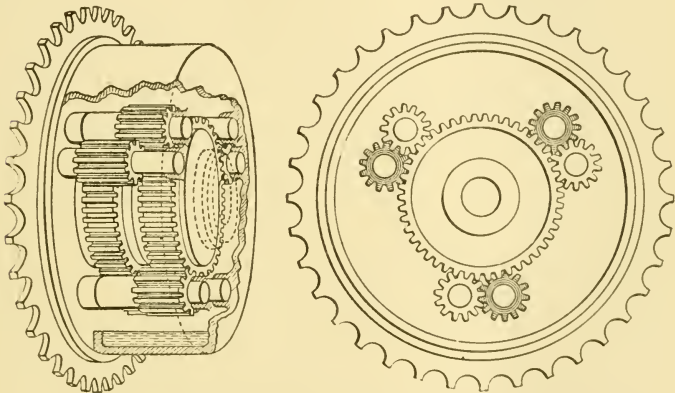

Figs. 191 and 192.—One form of spur differential or balance gear. The two inner ends of the divided axle shaft carry spur wheels which mesh each with one of every pair of the three pairs of spur pinions shown. As these pinions mesh together both rotate on their axes as soon as the car takes a curve.

the wheel offering the lesser resistance, 3, the pinions may rotate independently on one gear wheel, while still acting as a clutch on the other, sufficient in power to carry it forward, and 4, if a resistance be met of sufficient power to stop the rotation of both wheels and their axles, the condition would affect the entire mechanism, and the pinions would still remain stationary on their own axes, just as when in the act of transmitting an equal movement to both wheels.

For light service, the sprocket or spur drive generally carries two pinions, as shown in the figure, but in larger vehicles the

number is increased to three, four, or six, and the size, pitch, and number of the teeth are varied, according to requirements. Of course, it is essential that the equalizing gears be properly chosen for the work they are to perform, in the matter of the number of pinions and of their teeth, as well as of the metal used, on account of the great strain brought to bear on them.

Ques. Describe the spur differential.

Ans. In this variety, the theory of compensation is the same as with bevel gearing; a divided axle or jack shaft whose two inner ends carry gear wheels cut to mesh with pinions attached to the sprocket pulley. These pinions are, however, set in geared pairs, with their axes at right angles to the plane of the sprocket. As shown in figs. 191 and 192, the pinions of each pair are set alternately on one side or the other of the sprocket, meshing with one another in about half of their length, the remainder of each being left free to mesh with the axle spurs on the one or other side. The differential here illustrated, has three pairs of pinions, one of each meshing with either of the axle gears. With some differentials the divided axle carries internal gears, with others, true spur wheels. The operation is obvious. When the vehicle is turning, one rear wheel moves less rapidly, causing the pinion with which it is geared to revolve on its mate, which, in turn, revolves on its own axis, although still engaging the gear of the opposite and moving wheel of the vehicle.

RUNNING GEAR

The term running gear includes such parts as the frames, springs, axles, wheels, brakes, and steering gear.

In early construction, automobiles were built with some form of underframe, whose essential elements were "perches" connecting the front and rear axles, as in most horse carriages, and some form of swivel joint to permit of considerable distortion, in compensation for unevenness on the roadway.

The two objects sought in this supposedly necessary structure were strength and flexibility. Many designers used complicated frames of steel tubing, with the additional object of securing lightness. These elements have since been almost entirely abandoned, except in a few light steamers and electric wagons, for designers learned by experience that with properly arranged springs an automobile can be strong and flexible, without perches and swivels, and light, without steel tubing.

Answers Relating to The Running Gear

Ques. Describe a modern frame.

Ans. This consists of a rectangular frame, built of steel channels, suitably braced, and having several cross members. Attached to the ends are springs designed to absorb the vibration and shocks.

Ques. What is the construction of the springs?

Ans. The type generally used is known as the "leaf spring," and consists of several layers of steel plates or leaves slightly bent, so that, when laid together, they form a series of superposed arcs.

Ques. What feature is essential in a spring of this construction?

Ans. It is important that the line of the arc formed by the spring be carefully followed from end to end of each plate, and that no attempt be made to straighten or bend back the extremities of the longest leaves. This is true, because the spring effect is derived from the temper of the

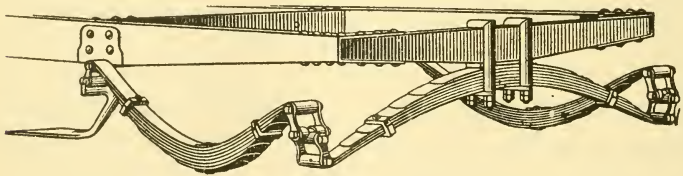

Fig. 193.—Three point suspended spring or platform spring.

metal in permitting the load to flatten all the arcs at once under a single stress, which involves that they should slide upon one another in altering their shape, as could not be the case were there any such departure from the line of the arc, as has been mentioned.

Ques. What three forms of leaf springs are used on automobiles?

Ans. The elliptical, the semi-elliptical, and the scroll.

Ques. Describe the three forms.

Ans. 1. The elliptical spring is formed by connecting two semi-elliptic or arc shaped springs at their extremities—generally by bolts passed through perforated bosses formed at the ends of the longest leaves—and is attached at the apex of each arc by clips or nuts.

2. The semi-elliptical spring consists of a segment formed by a number of leaves or blades, and is arranged to be attached at the bottom and the two extremities of the arc.

3. The scroll spring differs from the semi-elliptic in having one extremity of the arc rolled up and turned inward. It may be attached by a link or a shackle to a flat or semi-elliptical spring—forming a “scroll-elliptic”—or to the body suspended above the axle.

Ques. What two qualities are essential in a good spring?

Ans. Resistance and resilience.

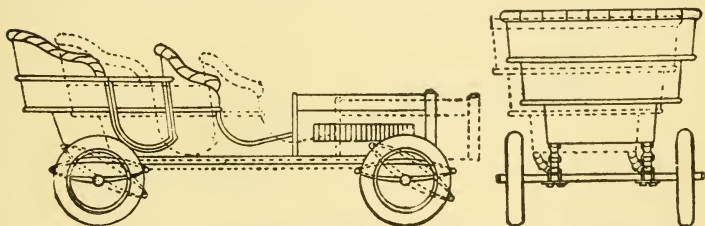

Figs. 194 and 195.—Diagrams illustrating the forward and sidewise lunges of the body of an automobile in travel, with indication of the distortion of the elliptical springs.

While a spring should be calculated to give sufficiently to absorb the jars of travel, it should not be so resilient as to rebound with a series of vibrations.

Ques. What is a shock absorber.

Ans. A device for insuring the gradual return of a spring to its original shape after being compressed, so as to deaden its rebounds and after movements by absorbing them with some form of frictional resistance.

One form of shock absorber is shown in fig. 196; it consists of the two arms, A and B, joined frictionally by bolt C. The arm, A, carries a cup-like bronze shell, D, and the arm B, a plate, F. A cup-like piece of oil soaked raw-hide is secured between the plate and the shell, being screwed by the nut G, on the bolt, C. An oil soaked leather washer separates it from the plate F. This nut is split and locked in place by the collar H. By screwing sufficiently, the nut G, any desired degree of friction may be obtained. The

arms, A and B are joined to the frame and the axle by two cone-like frictional joints, which also can be regulated.

Ques. What is a torsion rod?

Ans. A rod rigidly attached to the housing of the rear axle, and flexibly fastened to a cross member of the frame near the transmission.

Ques. Describe a second form of torsion rod.

Ans. A modified construction consists of a cylindrical sleeve, enclosing the propeller shaft, and attached rigidly to the bevel gear case; it is pivoted at the other end to the frame, or carried by a bearing on the shaft.

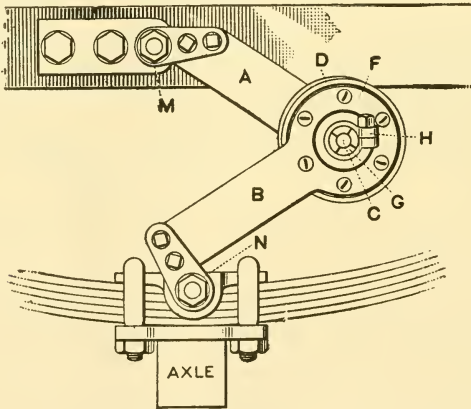

Fig. 196.—The Truffault spring suspension for neutralizing shocks due to sudden spring action.

Ques. What service does a torsion rod perform?

Ans. It resists the torque or twist due to the thrust of the propeller shaft pinion, which tends to cause the housing to revolve around the rear axle as a center.

Ques. What is a radius rod?

Ans. A rod used with a chain drive to resist the pull of the chain and maintain the rear axle at a fixed distance from the jack shaft.

Ques. Explain briefly the difference between a torsion rod and a radius rod.

Ans. A torsion rod resists the twist on the rear member, due to the action of a shaft drive, while a radius rod resists the thrust on the rear shaft caused by chain drive.

Ques. What provision is made to allow the shaft to move up and down?

Ans. With chain drive, the radius rod describes an arc, with the rear axle as center, while the springs rise and fall in travel. With shaft drive, a slip joint on the shaft is sufficient to compensate for the varying angle of the shaft.

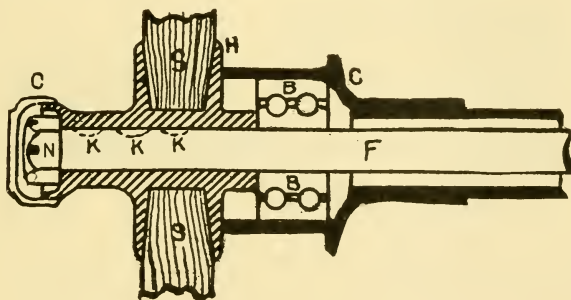

Fig. 197.—Semi-floating rear axle. In this construction the axle F, not only serves to transmit the power to the wheel, but also to support the weight of the car.

Ques. What is the distinction between a “dead” and a “live” axle?

Ans. A dead axle does not turn; a live axle turns with the wheels.

Ques. What is a “semi-floating” axle?

Ans. A semi-floating axle is one in which the wheels are secured directly to the transverse rear axle; it not only serves to turn the wheels, but also to support the weight of the car.

Fig. 197 illustrates a semi-floating rear axle. In this construction the wheel is attached directly to the rear axle, which not only serves to propel the wheel, but also to support the weight of the car. The hub H of the wheel is a snug fit on the end of the axle F, and the Woodruff keys K and the nut N serve to secure the wheel thereon. The hub cap C is not absolutely necessary, as it merely serves as an ornament, and to protect the nut N from being damaged by rust, bumps, and other hazards.

Ques. What is a "floating axle?"

Ans. A floating axle is one in which the wheels have a bearing entirely upon the rear axle housing, so that the

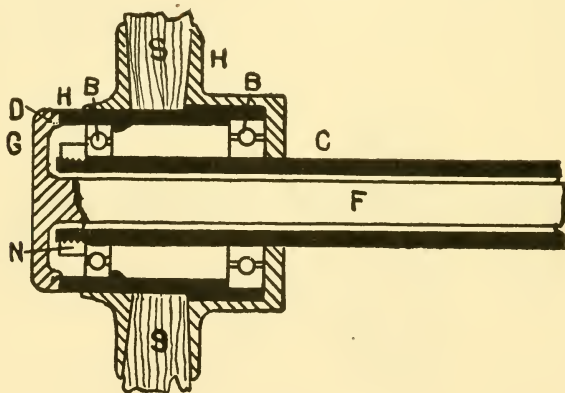

Fig. 198.—Floating rear axle. The weight of the car coming on the rear wheels is supported by the housing, while the axle serves only to transmit the motive power to the wheels.

weight of the car is carried entirely by the housing. The axle in this construction serves only to transmit the motive power to the wheels.

A floating type of rear axle is illustrated in fig. 198, C representing the housing, H the hub of the wheel, S the ends of the spokes of the wheel, and B the bearings. It will be noticed that the wheel bears directly on the housing C and is held by the nut N. The axle F has a flanged end G which forms a clutch that meshes with the outer edge of the hub H, the depth of the notches in the clutch and hub being represented by the dotted line D. The clutch and shaft are held in place by the hub cap, and in this construction the length of axle F on either side of the driving gear and differential mechanism may be pulled out of the housing by simply removing

the hub cap and without removing the wheel. Thus the differential and driving gear unit may also be removed without disturbing the axle.

Automobile wheels should have the following qualities of construction:

1. They must be sufficiently strong for the load they are to carry, and for the kind of roads on which they are to run.

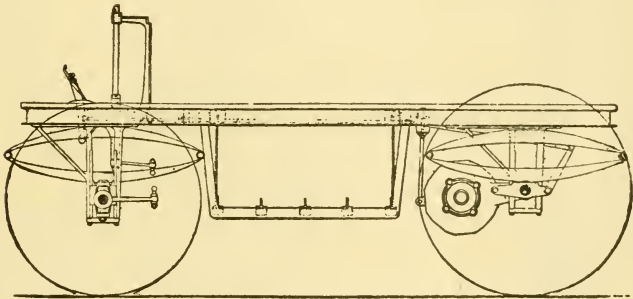

Fig. 199.—The Ranier pedestal frame, designed to control the movement of elliptical springs, preventing all distortions in travel.

2. They must be elastic, or so constructed that the several parts—hub, spokes and felloes, or rims—are susceptible of a certain flexibility in their fixed relations, thus neutralizing much vibration, and allowing the vehicle greater freedom of movement, particularly on short curves and when encountering obstacles.

3. They must, furthermore, be sufficiently light to avoid absorbing unnecessary power in moving.

4. They must be able to resist the torsion of the motor, which always tends to produce a tangential strain. This is the reason why tangent suspended wire wheels are

invariably used on automobiles, instead of the other variety, having radial spokes.

5. They must have sufficient adhesion to drive ahead without unduly absorbing power in overcoming the tendency to slip on an imperfect road.

The importance of the two last considerations may be readily understood, in view of the fact that the wheels receive the driving

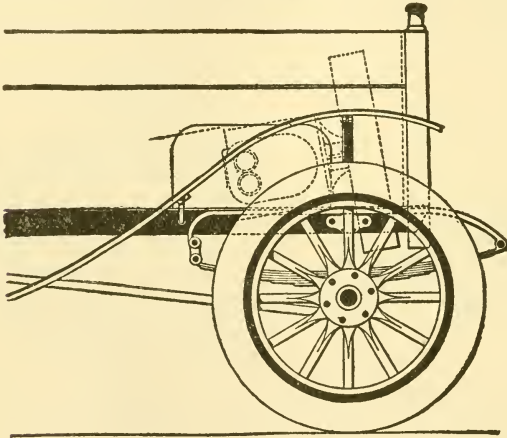

Fig. 200.—Forward running gear of the Northern car, showing springs connected with a vertical shackle. With this arrangement, it is claimed the return of the spring will be confined to the power of its tension or deflected state. It must return through the shackle on dead center, as it were, and not through the shackle as a hinge.

power direct instead of being merely rotating supports, like the wheels of horse drawn vehicles.

Ques. What is the approved type of wheel?

Ans. The wooden, or so called "artillery wheel."

Ques. Describe the construction of the artillery wheel.

Ans. A number of wedge spokes are set together around the nave, and a hub formed of steel plates at front and rear; these are bolted through the spokes, thus holding them firmly in place. The spokes terminate in a substantial

wooden rim which is provided with a suitable metal flange for attachment of the tire. The construction of wooden wheels is shown in figs. 201 to 204.

Ques. What is "dishing" of wheels?

Ans. The slight inclination of the spokes from the outside plane of the rim inwardly, so as to make the wheel a kind of flattened cone.

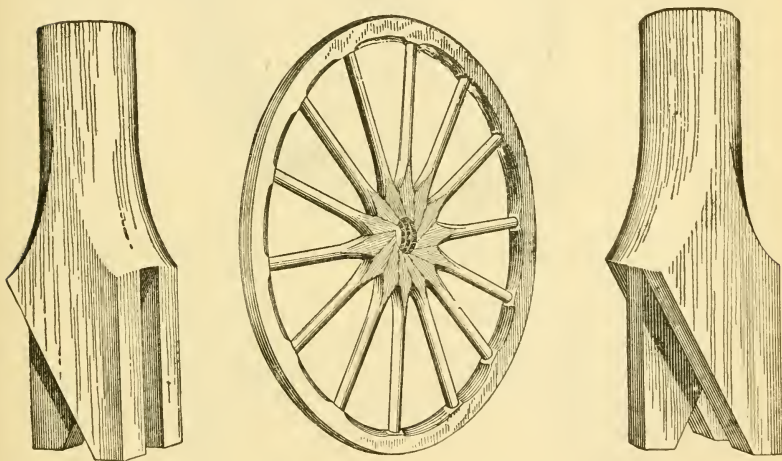

Figs. 201 to 203.—Construction of wooden artillery wheel with tongue and groove joint between the spoke wedges, ensuring great strength and rigidity.

Ques. What is the advantage of this construction?

Ans. It transforms the spokes into so many springs, possessing elastic properties, and renders the wheel capable of being deformed under sidewise stress. The shocks of collision with obstacles are thus distributed through the flexibly connected parts, as could not be the case if the wheel were made in one piece or on one plane, and the consequent wear and strain is greatly reduced.

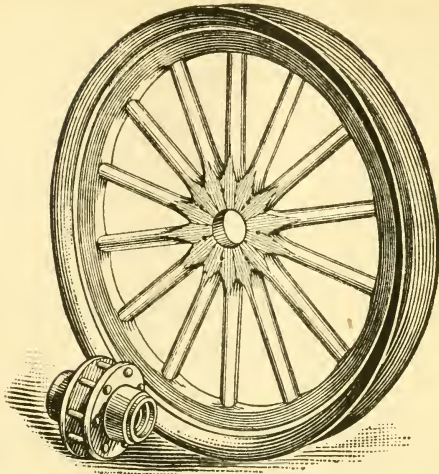

Figs. 204 and 205.—A typical wooden artillery or wedge wheel showing manner of setting the spokes and the construction of the hub.

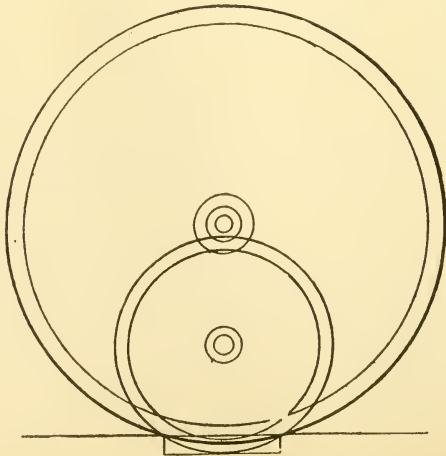

Fig. 206.—Diagram showing the relative drop into a road rut between a small carriage wheel and one twice its diameter.

Ques. How is the dish usually balanced?

Ans. By slightly inclining the axle spindle from its center line, as shown in fig. 207, thus bringing the lowest spoke to a nearly vertical position.

Ques. How is the action of a wheel influenced by its size?

Ans. The larger the wheel the smaller the shocks experienced in passing over inequalities in the road

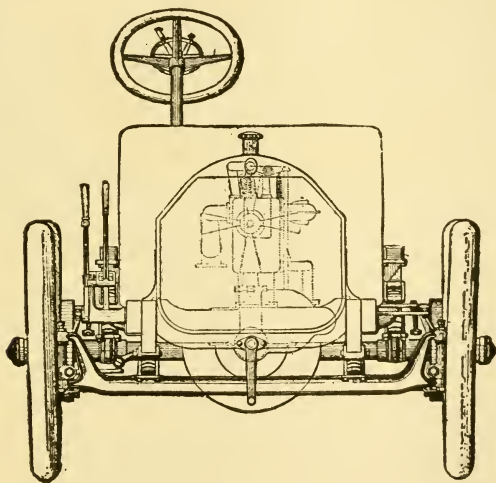

Fig. 207.—To illustrate the inclination of the wheels. The cut shows a Matheson car having the front wheels inclined three degrees to balance the "dishing" of the spokes and bring the lowest spoke into a vertical position.

Thus it is that a wheel five feet in diameter will sink only one-half inch in a rut one foot wide, while a thirty inch wheel, as shown in fig. 206, will sink nearly three times as deep, with the result that the resiliency of its tires must be much larger, in order to compensate for the greater shock experienced. The larger wheel also rises less quickly over obstructions.

There are, however, other methods for neutralizing the shocks on rough roads. The end of obtaining a low and easy running rig may be achieved quite as well by increasing the length of the vehicle, the length of the springs and the size of the tires, as by

adding to the height above the ground. Also, the broad tire is superior to the narrow one in the very same particular that it will not sink so quickly into mud and sand, and, by its greater buffing properties, neutralizes the concussion otherwise experienced with small wheels. These and other similar considerations have largely determined the prevalent practice of using wheels of moderate diameter for automobiles.

TIRES

Tires are used on automobiles, motor cycles, and a large number of horse drawn vehicles, to secure a desirable spring effect or cushion so as to reduce vibration to a minimum, and to obtain a large traction area to prevent the wheels sinking in soft roadway.

The most efficient shock absorbing medium is compressed air. This method of reducing vibration, however, as exemplified by the pneumatic tire, has the disadvantage that rubber, which is the only elastic air confining substance available, is liable to puncture.

There are in general use three varieties of tire: solid, cushion, and pneumatic.

As is generally known, the pneumatic tire was first devised in order to furnish the needed resiliency in bicycles, and for the same purpose it has been found useful in automobiles. It is also superior in point of tractive qualities, "taking hold" of the road bed far more effectively than the best solid tire. It has, however, one notable disadvantage, the constant liability to puncture, with the consequent danger of being rendered useless. In order to remedy this defect, inventors and manufacturers have introduced such features as thickening the tread of the tire, increasing its resistance to puncture by inserting layers of tough fabric in the rubber walls, and reinforcing the tread surface in various ways.

Pneumatic tires are almost universally used on automobiles, the solid type being confined to electrics and trucks intended for city service.

Answers Relating to Tires

Ques. What is rubber?

Ans. Rubber is a white, usually thick, milky juice, contained in the spongy bark of various tropical trees.

The popular idea is that rubber comes from the sap of a tree; it is, as explained in the answer, a totally different substance.

Ques. How is raw rubber treated after removal from the tree?

Ans. The juice is mixed with sulphur and various other powders, made into a dough, and baked.

There is no melting or casting as generally believed, but simply a baking process, with a sticky gum, which, during the baking, changes into an unsticky and more elastic gum, and acquires other desirable properties.

When the crude rubber reaches the manufacturer it is full of impurities which must be washed out. The rubber then, is run through a washer, and when clean, is hung up in a slightly heated room until dry. It is now run around one smooth roll of the mixing mill, and becomes soft, slightly sticky, and readily takes up any ingredient in powder form that is to be mixed with it. When the mixture is complete, the mass is in the form of a log, dark colored, and very dense.

In order to use it, the mass must be ironed out into sheets. This is done by large heavy steam heated rolls, which, in the case of tire making, smooth the rubber out upon cloth, in a thin and even coating, and drive it between the meshes so that every space is filled.

Ques. Upon what does the strength of a tire depend?

Ans. Largely upon the fabric upon which the rubber is rolled.

The elasticity, air proof and water proof qualities come from the rubber.

Ques. What is the tendency of cuts in solid tires?

Ans. Cuts, due to stones or other sharp obstacles, tend to spread to the center of the tire, across the tread.

Ques. Why is this, and how prevented?

Ans. This is due to the quality of the strains transmitted from the wheels, and in order to prevent the destruction of the tire, it is necessary to vary the shape. Accordingly, tires are made with bevelled edges, rather than on square lines. This conformation, together with a good width at the rim, is able to provide for absorbing much of the surplus vibration, while decreasing the ill effects due to the combined action of a heavy load and road resistance.

Ques. What are the advantages of the "pneumatic" tire?

Ans. The most valuable quality of the pneumatic tire is its resiliency, or ability to bounce in the act of regaining its usual form after encountering an obstacle in the road. On encountering a stone, for example, it will yield to a certain extent, absorbing or "swallowing it up," at the same time exerting a pressure sufficient to restore its normal shape.

The latter quality has two advantages for easy riding; 1, it does away with much of the lifting up of the wheel in passing over obstacles, which is otherwise inevitable, and 2, it enables the tire to obtain a better grip on the roadbed.

Ques. Name two varieties of pneumatic tire.

Ans. The "single tube," and the "double tube."

Ques. Describe them.

Ans. The double tube tire was first introduced, and in all its various forms consists of an inner, or air tube, made of thin elastic rubber, enclosed in an outer or case tube, or shoe, built up of strong fabric and a tougher and denser kind of rubber. The shoe is split on its inner face, which

bears against the rim of the wheel, in order to allow the air tube to be readily removed at any time for repair or replacement. The single tube tire was devised as an improvement, whereby the layers of thread and tough rubber are formed upon and around the delicate air tube making the two tubes really one. The double tube tire is commonly used on automobiles, as it is better adapted to heavy duty.

Ques. How are single tube tires attached to the wheel?

Ans. They are attached by bolts passing through the rim and secured by wing nuts on the inside surface, or by cementing the tire to the rim. Each bolt is of one piece with a head or plate embedded in the fabric. While such attachment is sufficiently strong under ordinary conditions, particularly when the tire is thoroughly inflated, it is desirable to apply a coating of shellac in the rim channel, in order to prevent the accumulation of dust and sand, which are always seriously destructive to the tire.

Ques. What are the advantages of double tube tires?

Ans. They are practically free from creeping, on account of the security of the attachment to the wheel rim. They will not "roll off," although the attempt to turn sharp corners at high speed strains the fabric, and at times may result in rupture.

Ques. Describe a double tube tire.

Ans. It consists of an inner tube which contains the compressed air, and an outer casing or shoe; the shoe is open along its inner circumference, has projections or flanges which fit snugly into channels formed by inturning the edges of the rim to hold the tire in place. These channels are the "clinches," hence, the name "clincher tire." Sometimes the inner tube is protected by a "flap."

In removing the shoe, it is necessary to insert a flat tool between it and the rim and pry them apart. This operation is

tedious, and also involves severe strain on the fabric. A careless hand may also cut or bruise the inner tube, particularly when it is not protected by a flap.

Ques. How is the clincher tire modified to permit its ready removal?

Ans. The rim is made in two sections, so that one side may be detached, permitting the tire to be easily taken off.

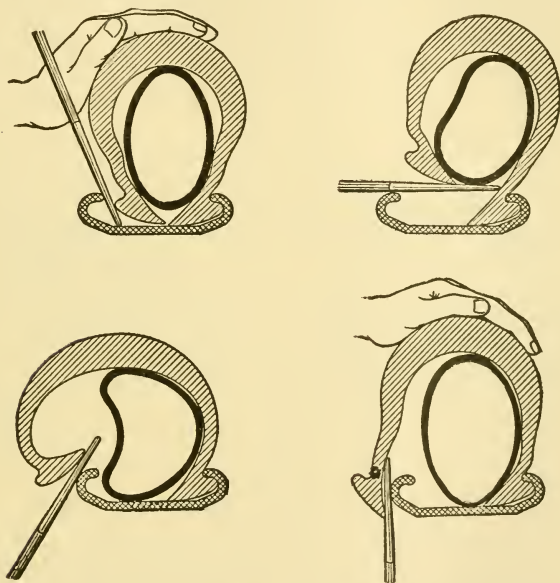

Figs. 208 to 211.—Showing successive stages in the removal of the casing or shoe of a clincher pneumatic tire by the insertion of a tire tool.

Ques. How is a clincher tire removed?

Ans. The wheel is first lifted from the ground and the tire deflated through the air valve. One side of the shoe is removed from the clincher groove with a pair of blunt iron "prodders," care being used not to pinch or tear the inner tube; this is now removed by hand, beginning at the part

farthest from the air valve. A double prong iron is used to raise the shoe somewhat, in detaching the air valve from the rim.

Ques. How should a tire be replaced on the rim?

Ans. Before putting on the tire, powdered talcum is rubbed on the inner tube, and a liberal supply distributed inside the shoe. The inner tube is placed in the shoe and slightly inflated. After passing the hand carefully around the tube to see that there are no twists, the shoe is forced in place by the use of the "tire irons," lifting each clamp as the

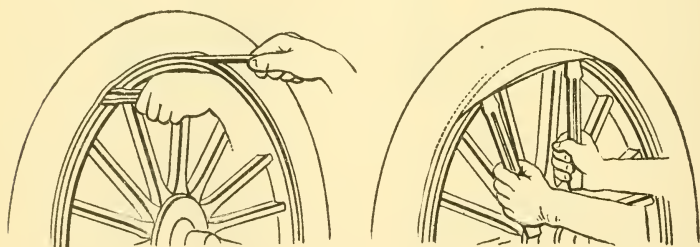

Figs. 212 and 213.—Showing method of removing a shoe with two levers.

part of the shoe next to it is sprung into position. The clamps are pushed in to see whether the inner tube lifts freely. If not, it may be pinched under the clamps and should be released. The clamps should now be tightened and the tire inflated.

Ques. How should extra tires be carried?

Ans. They should be kept in cases, such as are provided for the purpose by tire dealers. This rule applies with particular force to the very elastic inner tubes, which should be stored in bags in some convenient place away from the light and heat of the sun.

Tires in use are not as liable to injury from sunlight as the extra stored tires, for the reason that the dust and mud of travel, while not directly contributing to the advantage of the rubber, seem to neutralize the ill effects of the sun's rays. This is the best explanation of the fact that used tires are less liable to injury than new ones.

Answers Relating to Tire Troubles, Care and Repairs

Ques. Name some forms of wear and tear of pneumatic tires.

Ans. 1, creeping, 2, puncture, 3, rim cutting, 4, cracking of the walls, 5, excessive wear on the walls or tread, and 6, chemical action.

Ques. What may be said of creeping?

Ans. Creeping is found almost exclusively in single tube tires. It is due to the fact that the weight of the vehicle in process of travel, tends to centralize the pressure on the rubber walls, and to cause the tire to bulge just forward of the point of contact with the ground. As may be readily recognized, a continued succession of such bulgings tends both to loosen the adhesion between the tire and the rim, and to cause the tire to push forward from the ground, and thus around the rim. As a result, when inflation is insufficient, great strain and pull will be exerted where the valve is joined to the tire, and a rupture often follows at that point.

Even were it possible to obviate the last named trouble, it is evident that the service of a tire, thus loosened by the creeping process, is impaired. Moreover, it would inevitably roll sideways from the rim before it had been long in use. Also, if loose, it will chafe at the rim and wear quickly. The only assurance against creeping in a single tube tire is found in reliable bolt and lug fastenings. Double tube tires are free from creeping on account of having complete rim attachments in clinches, side flanges, etc.



FIG. 214.



FIG. 215.



FIG. 216.



FIG. 217.

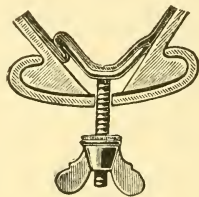

FIG. 218.

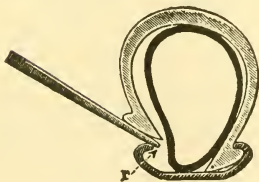

FIG. 219.

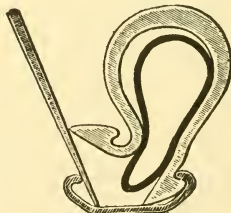

FIG. 220.

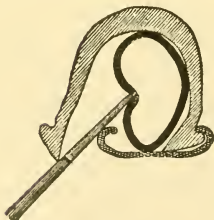

FIG. 221.

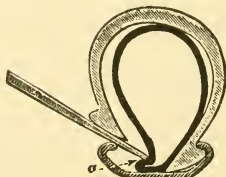

FIG. 222.

Figs. 214 to 222.—Diagrams of various mishaps to pneumatic tires. Fig. 214 shows the air tube resting over a perfectly fitting chaplet head; figs. 215 and 216, the effects of poorly fitting chaplets, showing liability to pinching of the air tube; fig. 217, air pinched under the edge of case tube; fig. 218, air tube pinched to pull down chaplet, in both these cases the air tube is not sufficiently inflated while attaching the case tube; figs. 219 and 220, the right and wrong way to raise the edge of the case tube over the clinch; figs. 221 and 222, two ways in which the air tube may be nipped by allowing the tire tool to penetrate too far.

Ques. What is a puncture, and how caused?

Ans. The accident known as a puncture, is a piercing of the air tube which allows the air to escape and so flatten the tire. It is generally caused by a sharp stone or a nail piercing the tread.

Among other possible causes of puncture are :

1. Nipping of the air tube by the "removal lever"; by the lug of the screw bolt; by the edge of the shoe.
2. Sand or other hard substances in the case tube or shoe.

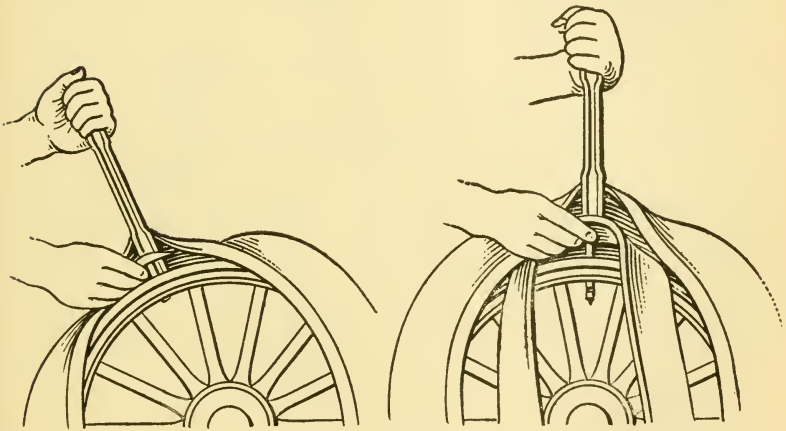

Figs. 223 and 224.—Showing method of removing the inner tube with a single (stepped) lever.

Ques. If the inner tube be punctured, what should be done?

Ans. The inside of the shoe should first be carefully examined to locate the cause of the puncture.

Ques. How may a puncture be repaired?

Ans. Having found the puncture, either by immersing the tube in water or by dusting with powdered "talcum," with a little air pressure in the tube, a rubber patch is put over the puncture.

Ques. How is the patch applied?

Ans. The inner tube is first rubbed with sand paper all around the puncture to obtain a clean surface. For a temporary patch, liquid rubber cement is applied to the tube and on one side of the patch. After the cement dries sufficiently to become sticky, the patch is placed in position on the tube with a rolling motion, so as to exclude all air, from beneath it. The tube is now laid on a smooth surface and a weighted board placed on top, and left until the cement sets.

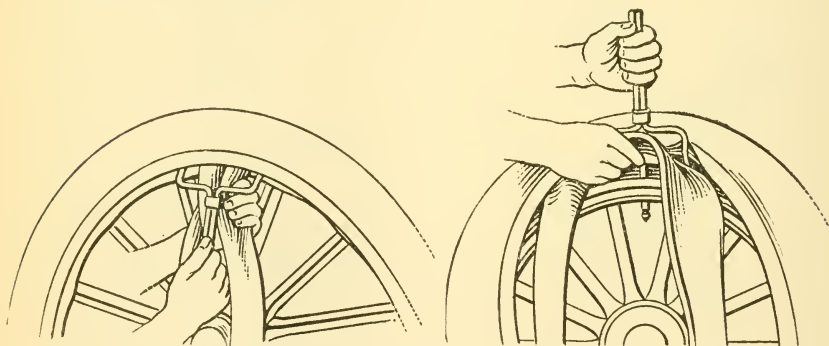

Figs. 225 and 226.—Showing method of removing the inner tube with a double lever.

Ques. Is this kind of patch durable?

Ans. With careful driving at moderate speeds it will last for some time without vulcanizing.

Answers Relating to Vulcanizing

Ques. How is a small cut in the shoe repaired?

Ans. By vulcanizing. The torn surfaces should be scraped clean, and the aperture filled with prepared plastic rubber, and then vulcanized.

Ques. How is a patch vulcanized?

Ans. After the patch is put on, it is heated to a temperature of about 250° Fahr., by a vulcanizer—a special form of heater made for the purpose. The duration of the heating depends on the amount of rubber that has to be heated, the usual interval being about fifteen minutes.

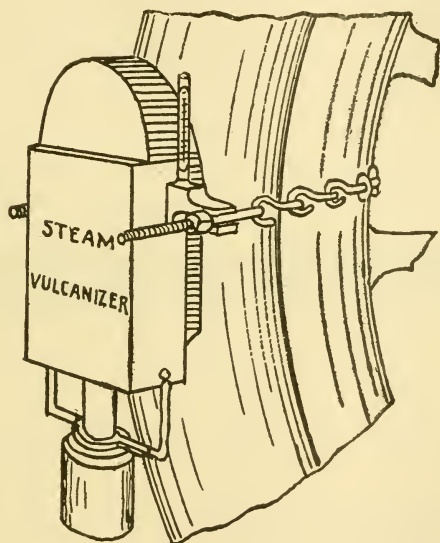

Fig. 227.—National steam vulcanizer. It consists of a hollow brass vessel partly filled with water and heated by an alcohol lamp. The water is converted into steam, the temperature of which depends on the pressure.

There are numerous forms of vulcanizer. They are heated by steam, electricity, gasoline, or gas. Steam vulcanizers are provided with a steam gauge from which the temperature is determined.

Ques. What is the proper temperature for vulcanizing?

Ans. 250° for light work; about 275° on heavy shoes.

Rubber is easily injured by over heating, hence, the operator should be careful to prevent the vulcanizer becoming too hot.

Answers Relating to Rim Cutting

Ques. What precaution should be taken with respect to the rim before putting on a tire?

Ans. It should be thoroughly cleaned. A fine file or emery cloth should be used to smooth the rim of rough places, and to remove rust. The inside of the rim should be given a light coat of thin shellac.

Ques. What is the effect of a dent in the rim?

Ans. If the rim be dented inward, an excess pressure is brought upon the shoe at that point, which will cause

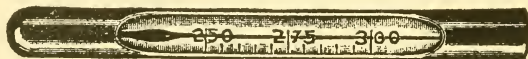

Fig. 228.—Thermometer for use with vulcanizers; it has a stem graduated from 250 to 300° Fahr., covering the temperature used in vulcanizing.

chafing. If the dent or bend be outward, there is chance for water, oil, and sand to work in between the tire and the rim.

Ques. What are the causes of rim cutting?

Ans. 1. Sand or sharp particles lodged between the tire and the edges of the rim, which, particularly when the tire is partially deflated, cut through the outer layer of rubber to the fabric beneath.

2. Overloading.

This causes the tire to flatten, in spite of persistent extra inflation, and the result is nearly always shearing off at the edges near the points where the flanges engage the clinches.

3. Defective or bent rims.

Rims may be unsuitable for given makes of tire, because made for some other style. It is essential that the tire fit the rim

perfectly, since, if the attachment be not tight, movement and chafing result, or stones and sand find lodgment; if it be too tight, the pressure against the edges of the rim is excessive.

Loose or ill fitting studs always allow some movement of the tire, which usually results in cutting, at least in spots around the rim.

These mishaps occur less frequently than those due to bent or rusty rims, which work the same havoc as those that fit poorly. It is necessary to keep the rim in repair, and to clean out all evidences of rust.

4. Insufficient inflation.

This is often a cause of cutting, even when the rims are in good condition. It is necessary to keep the tires pumped hard at all times. If cutting then result, it is evident that the tires are too small for the load they are obliged to carry.

5. Sharp curves or excessive "side step."

Both tend to produce a side pressure that is concentrated at the rim, and, in proportion to the weight of the car, or the speed at which it is driven, are liable to result in cutting of the shoe. Side slipping or skidding is largely neutralized in cars with long wheel base, but, even with this desirable structural feature, occasions may arise in which rim cutting results from sudden turns.

Answers Relating to Inflation

Ques. What causes a tire to crack?

Ans. If a tire be well made, any evidence of cracking of the shoe may safely be attributed to driving with insufficient inflation. As the result of a puncture or other mishap, all the air may be exhausted, causing the tire to be completely flattened under the weight of the vehicle. This is liable to cause cracking. Long continued pressure of this kind tears and destroys the fabric of the tire.

Ques. In the care of tires, what is the most important thing to be done?

Ans. To keep the tire inflated to the proper pressure.

To neglect this, will cause the rapid deterioration of the tire. Running a tire flat, even a short distance, will prove expensive.

Table showing Proper Loading and Inflation of Tires

Size of Tire	Load per Wheel Pounds	Air Pres. Lbs. per sq. in.
28 to 30x2½	225	50
26 to 36x3 & 31x3½	350	60
29x3½	425	70
30x3½ & 31x4	450	
31x3½	500	
32x3½ & 33x4	555	
34x3½ & 35x4	600	
36x3½	600	
30x4	550	80
31x4	600	
32x4 & 33x4½	650	
33x4	675	
34x4 & 35x4½	700	
35x4	725	
36x4	750	
32x4½	700	90
33x4½	750	
34x4½ & 35x5	800	
35x4½	850	
36x4½ & 37x5	900	
35x5	900	100
36x5	1,000	
37x5	1,100	

The above table shows the maximum pressures to which the various sizes of tires should be inflated, and the maximum weights they should support, but the secret of big tire mileage is to pump just enough air—and no more—than will give them their natural shape under the load.

Instructions for the Proper Care of Tires

The brake should not be applied suddenly unless absolutely necessary.

When one side of a tire shows more wear than another, it should be turned around, so as to reverse the sides.

High speed is very destructive to tires.

Grease and oils should be regularly kept away from tires; they attack the rubber.

Rims should be kept in good order, straight and true. Rust is destructive. Paint preserves.

The weight of the car should not rest on deflated tires, not even over night.

It is better to run on the rim, very slowly and carefully, if necessary and the distance be short, than on a flat tire.

Rear tires wear the more rapidly. Front and rear tires can therefore, be transposed sometimes to advantage.

The throttle should be used more, and the brakes less, in controlling the car. This saves both the tires and the machine.

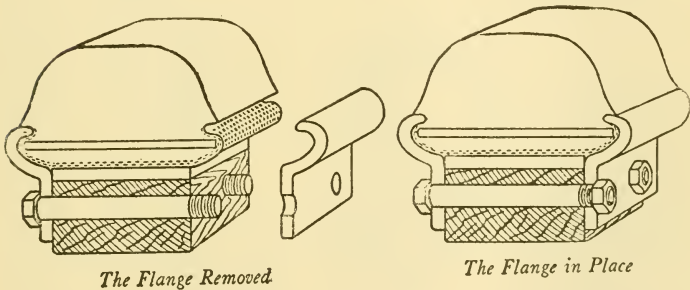

Figs. 229 and 230.—Swinehart flange rim with solid tire, showing flange removed, and flange in place.

There is not much danger of bursting a tire by too much inflation, unless it be considerably weakened by age or injury. A tire can be over inflated, but seldom is this the case.

Ques. What is the effect of dampness on stored tires?

Ans. Dampness acts on the fabric far more quickly than water; the latter has the peculiar faculty of penetrating even the minutest chinks or punctures, and is rapidly absorbed by the fibres composing the tire fabric. Only one result can follow: the fabric will be broken down and the shoe correspondingly weakened.

When in constant use, the fabric of a tire is in little danger of deterioration from water, although dampness in the stable should

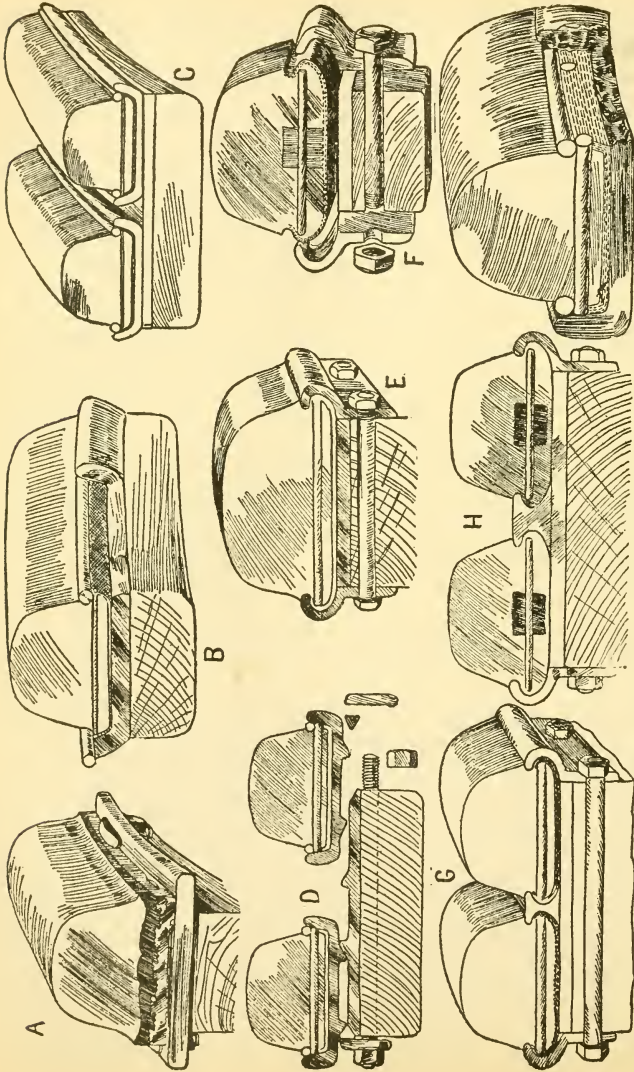

Figs. 231 to 239.—Different types of tire for power wagons. A, The Goodrich wireless single tire; B, Diamond side wire single tire; C, The Diamond side wire as a double tire; D, The Firestone cross wire demountable type; E and F, Swinehart dual demountable cross wire tire; G and H, Republic dual demountable with cross wires in a hard rubber core; I, The Morgan & Wright side wire tire has cross wires.

always be avoided. A tire in use, however, is exposed to an even graver danger: a cut in the tread of the case tube may admit sand or mud, which, working under the outer layer of rubber, will form a pocket where water may collect and begin work on the fabric. Any sign of a cut or **blister**, that is, lumps covering sand or mud, should warn the driver that the tire needs repair.

Ques. What is the effect when the front wheels are not parallel?

Ans. There is liable to be considerable wear on the treads.

This results because both wheels must slide in a sidewise direction, involving an unnecessary waste of good rubber.

Ques. What causes non-parallelism of the front wheels?

Ans. It is generally due to a short or bent drag link between the steering arms.

Ques. Name some causes of excessive wear of tires that can be avoided.

Ans. 1. High speed, especially on curves, and 2, sudden braking.

The latter, though unavoidable in emergency, is the general practice of some drivers, and is the cause of unnecessary tire expenses. Sometimes the brakes are applied with such force as to cause the wheels to slide, before the momentum of the car is overcome; this is inexcusable, as the car may be brought to a standstill quicker if the wheels do not slide. For sake of preserving the tires, if for no other reason, the brake of an automobile should be applied as gradually as possible.

Ques. What precaution should be taken in regard to curb stones?

Ans. Care should be taken not to drive against them, as this causes wear upon the sides of the tire.

Ques. What may be said regarding the wear of the tread of the tire?

Ans. A tire necessarily undergoes considerable wear in course of use. With the best possible roads and the highest grade of rubber, a more or less rapid deterioration is inevitable. For this, of course, there is no remedy. It is desirable, however, to avoid excessive wear whenever possible. No tire should be used after the rubber at the tread, or side

walls, has been worn down to the fabric. The result will be that the structure is weakened, offering a smaller resistance to puncture and tearing, also exposing the fibre to the destructive action of water and other corrodents, not to mention the more rapid wear due to abradants, as sand, etc.

Ques. How does chemical action affect a tire?

Ans. The rubber suffers chemical deterioration from the action of oil, gasoline or acids. These substances are always destructive in their action. If, therefore, gasoline

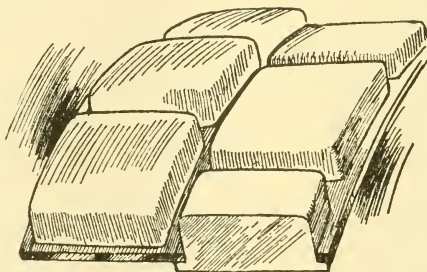

Fig. 240.—Kelly-Springfield block tire. A steel band on the felloe is cut out with rectangular staggered holes, into which fit solid blocks of rubber.

or oil be accidentally spilled upon a tire, it should be wiped clean as quickly as possible, and care exercised not to allow the wheels to stand in casual puddles of oil. Under the action of these substances, rubber hardens, losing its elasticity and tenacity, and developing a tendency to wear and chip.

Strong and steady light, as well as high or changing temperature, is harmful to rubber.

Particularly, it must be said, rubber should never be left near a window, so that the sun shines through the glass upon it. Sunlight, under such conditions, tends to harden the rubber, causing it to crack. Heat acts in a similar fashion, although, unless excessive, far more slowly.

BRAKES

An important subject in connection with the construction and operation of automobiles, relates to the brakes used for retarding the movement of the car when it is desirable to come to a more or less sudden stop, or to hold the car stationary on an incline. A good brake must fulfill several conditions, such as, ease and rapidity of operation and the maximum of braking effect, with the minimum of power exerted at the operating lever.

Answers Relating to Brakes

Ques. What two kinds of brake are used in driving an automobile?

Ans. The "service" or "running" brake, and the "emergency" brake.

Ques. How are these brakes operated?

Ans. The running brake is controlled by a foot pedal, and the emergency brake by a lever at the driver's side.

Ques. What other mechanism beside the running brake is connected with the brake pedal?

Ans. The clutch; the connection is such that when the pedal is pressed to apply the brake, the clutch is released. This arrangement prevents an inexperienced or confused driver applying the brake without releasing the clutch—a proceeding which would strain or bring heavy stresses on the engine and driving gear.

Sometimes the emergency brake is arranged to simultaneously release the clutch when applied, but this construction has been criticized by some authorities as undesirable when handling a car on a hill.

It is pointed out, that if necessary to stop the car in ascending a hill, the brakes must be released before the clutch can be thrown in, with the possibility of the car starting down hill backward before the power can be applied.

The chance of stalling the engine through this and the danger of the combination to any but an experienced driver, it is contended, make it advisable to have the emergency brake separate from any connection with the clutch.

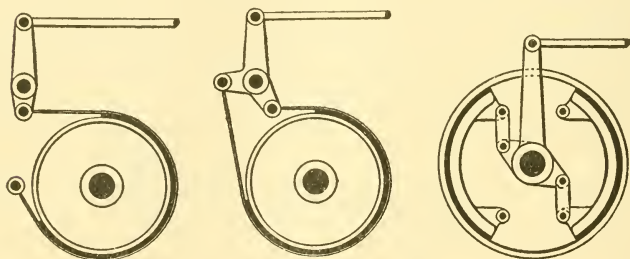

Figs. 241 to 243.—Three forms of brake: 1, single acting contracting brake; 2, double acting contracting brake; 3, expanding brake.

Ques. Describe the construction of the brakes.

Ans. The form generally used consists of a drum, attached to the wheel or some other part of the power transmission system, and a band which surrounds it, or blocks that press against its inner surface, the former being known as a "contracting brake," and the latter an "expanding brake."

Ques. Name two forms of band brake.

Ans. The "single," and the "double acting."

Ques. How do they differ?

Ans. One end of the band of the single acting brake is attached to the frame of the car or some other stationary

part, as shown in fig. 241, and pressure applied by drawing the free end. In the double acting type, both ends of the band are pulled, as shown in fig. 242.

Ques. How does the action differ in these two types?

Ans. In the single acting type the friction of the band restrains the movement if the drum be revolving in the opposite direction to the pull, but the device is less effective when the drum is revolving in the same direction. Since,

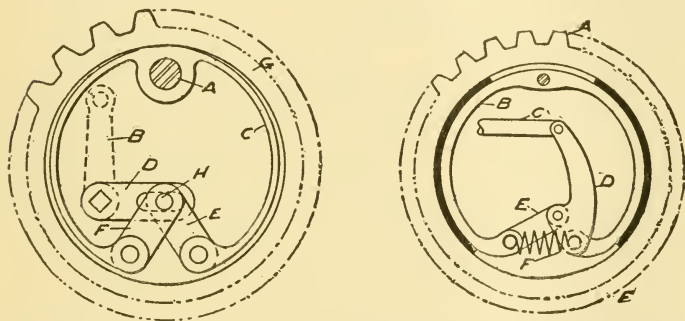

Figs. 244 and 245.—Two forms of expanding band brake. In fig. 244 the gear G has an internal bearing surface, within which is the band C, pivoted at A, a point separate from G. The arm, B, of the bell crank, BD, being moved to the left, spreads apart from the two links, E and F, connected to D at H, thus pressing both ends of the band, C, against the internal bearing surface of G, and producing the necessary breaking friction. In fig. 245, the gear A, similarly arranged with an internal bearing surface, contains the expanding band, B. When the link C is pulled the lever arm, D, double pivoted at E and F, causes the two ends of the band, B, to press against the internal bearing surface of A, thus creating friction. The spring shown normally holds the two ends of the band apart.

in the double acting type, both ends of the band are pulled, the action of the brake is equally effective in either direction.

Ques. How is an expanding brake constructed?

Ans. This type of brake, as shown in fig. 243, usually consists of two circular bronze shoes, which fit the interior circumference of the drum. The shoes are pivoted at one

end, and so arranged that in operation they expand and press against the drum. They are commonly held out of contact by a spring.

Ques. What device is necessary in the operation of brakes applied to the rear wheels?

Ans. There must be an "equalizer" so that each brake may be applied with equal pressure, otherwise the car will have a tendency to slide sideways.

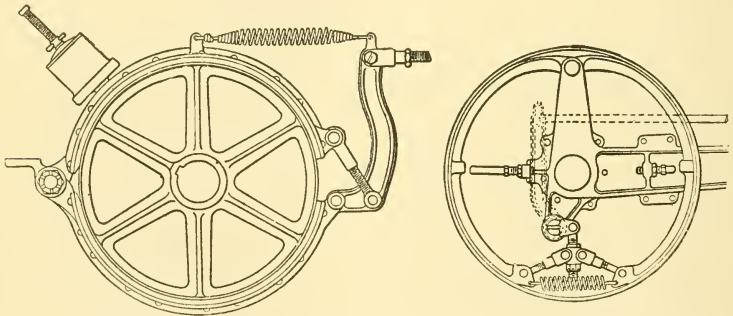

Figs. 246 and 247 The Locomobile brakes. The running brake consists of a contracting band brake, the pulley of which is located on the differential shaft at the right of the bronze gear case, and to which the band is firmly secured. This brake is of the double acting type, 12 inches in diameter and 4 inches wide. The brake pedal is operated by the right foot and when the brake is engaged the clutch is not automatically disconnected. The halves of the brake band are automatically hinged at the rear and are adjusted in front by two turn buckles; it has also a set screw underneath, allowing the band to be adjusted so that it is free around the circumference of the pulley, preventing any binding when not in use. The emergency brakes are located on the rear wheels, being of the internal expansion variety, one to each wheel. These are hinged at the top and when the hand brake lever, placed at the right of the car, is pulled backward, suitable mechanism causes the brake shoes to be expanded against the circumference of the brake drum; when the lever is released, springs draw the bands away from the circumference of the drum.

Ques. Describe an equalizer.

Ans. It consists of a cross bar connected at its center with the brake pedal or lever, and at the ends with the brakes. In operation the pull of the pedal or lever being applied to the center of the equalizer, is distributed equally between the two brakes.

There are two forms of equalizer, the bar, and the cord equalizer. In fig. 248 an equalizer of the first mentioned type is shown connected at its central point to the brake lever or pedal by the rod R. The ends are connected to the brakes by the brake rods. When R is drawn forward, the pull on the brake rods is made equal by the action of the equalizer. In the cord equalizer, the cross bar of fig. 248 is replaced by a pulley around which passes a cord through which the pull is transmitted to the brakes and equalized.

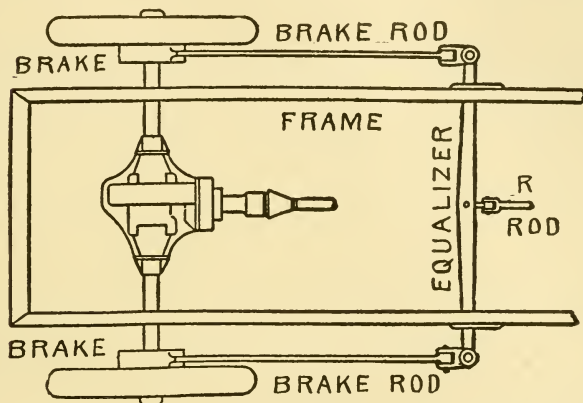

Fig. 248.—Equalizer of the bar type. It consists of a transverse bar with connections at its center and ends, respectively, to the brake pedal or lever and the brakes. A pull on the rod R is equally distributed between the two brake rods.

Ques. Does an equalizer always cause the brakes to act with equal force?

Ans. No; the purpose of the equalizer is realized only when both friction surfaces are in the same condition. Example: If one be dry and the other oily, the dry one will offer far greater resistance to turning.

Ques. What causes the brake to overheat?

Ans. Injudicious use often causes the leather to overheat and burn; this sometimes occurs when the brake is applied for a considerable period, as in descending a long hill.

Ques. How may this be avoided?

Ans. The emergency brake may be used on such occasions, as the friction surfaces are of metal, which will stand considerably more heat than leather.

Ques. What is the best mode of braking in descending long grades?

Ans. The engine should be used, as it will offer considerable resistance to the forward movement of the car when the ignition is cut out and the throttle closed; the work required to drive the engine, as an air compressor, is sufficient to check the speed of the car.*

Ques. How may the braking power of the engine be increased?

Ans. By running on the low speed gear.

Ques. What are the advantages of braking with the engine?

Ans. It saves wear on the brakes; can be resorted to in case of failure of the brakes; the cylinders are thoroughly scavenged and cooled, the latter being desirable in case of a very steep ascent immediately following.

Ques. If the brakes fail on a descent, what should be done?

Ans. The speed may be checked with the engine by releasing the clutch, switching off the ignition, engaging the intermediate speed gears, and applying the clutch very slowly.

If the clutch be thrown in suddenly the gears may be injured. With low speed, the checking would be so sudden, no matter how gradually the clutch be applied, that the passengers would possibly be thrown from their seats.

*NOTE—If the inlet manifold be fitted with an air valve for hand control, as described in the chapter on carburettors, it will be of great advantage when braking with the engine, because with closed throttle, fresh air may be admitted to the cylinders for scavenging and cooling.

BALL AND ROLLER BEARINGS

The principle of the ball bearing is a "nature made" idea, as embodied in the action of a good lubricant. The latter consists of a vast number of minutely dimensioned balls composed of fat, and tied together by a mother liquor which is capable of maintaining the distance relation of the globules, notwithstanding the variations in shapes and the distorting effects of pressure.

It was but a step from the nature made ball bearing, as represented by suitable grades of lubricating oil, to a regularly organized system of hardened steel balls rolling between suitable raceways.

The object of using ball bearings is to reduce friction, for with the plain bearing there is considerable resistance to rotation due to adhesion between the sliding surfaces. The heaviest objects may be readily moved or slid along the ground when rollers are placed beneath them; also the heaviest loads when carried on wheels of suitable breadth and diameter may be handled with a degree of ease. This principle is applied in the practice of substituting ball and roller bearings for ordinary plain bearings.

TABLE OF SAFE LOADS DWF RADIAL BEARINGS
(Medium Series)

Number of bearing.....	300	303	305	307	309
Bore.....	.394	.669	.984	1.378	1.772
Diameter (inches).....	1.378	1.850	2.441	3.150	3.937
Width.....	.433	.551	.669	.827	.984
Diameter balls.....	$\frac{1}{4}$	$\frac{5}{16}$	$\frac{3}{8}$	$\frac{1}{2}$	$\frac{5}{8}$
Load (lbs.).....	200	370	620	1100	1750

Answers Relating to Ball and Roller Bearings

Ques. What is the principal difference between a ball, and a roller bearing?

Ans. A ball bearing is a "point" bearing, in which the balls bear upon points of contact at two or more places on its surface; a roller bearing is a "line" bearing, in contact with its bearing surface in a straight line.

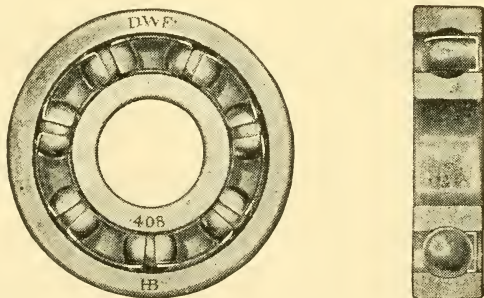

Figs. 249 and 250.—Side and end views of a radial bearing, showing balls, retainer, and raceway.

Ques. For what service is each adapted?

Ans. Ball bearings are generally used for high speeds and light loads, while roller bearings are used where the opposite conditions obtain. No definite rule can be adhered to, as it depends upon the conditions under which the bearings are to be used, just what type will give the most satisfactory service.

In automobile construction, the tendency is to use ball bearings on pleasure vehicles, and roller bearings on power wagons.

Ques. What forms of raceway are generally used with ball bearings?

Ans. Grooves are frequently used whose cross section is an arc of a circle having a diameter slightly larger than that of the ball.

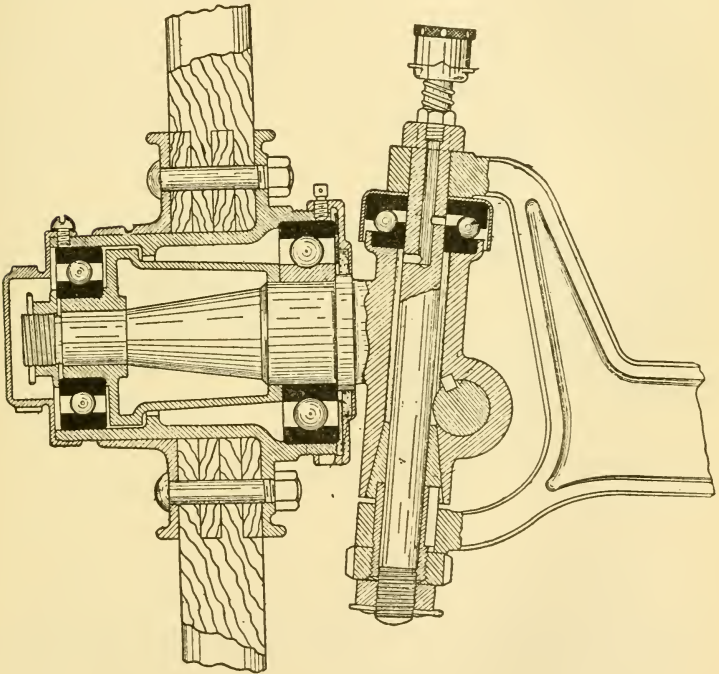

Fig. 251.—Front swivel axle of the Chadwick automobile; view showing the ball bearing. It will be noted that the steering axle bolt is not at right angles with the wheel axle. It is designed this way in order that shocks shall not be transmitted through the wheels to the gear, but will be absorbed in the axles.

Ques. Describe the “radial” type of ball bearing.

Ans. In this form, as shown in figs. 249 and 250, the balls are inserted between two grooved rings.

Ques. What is the distinction between the "silent" and the "full" type of ball bearing?

Ans. The silent type consists of a raceway entirely filled with balls, while the full type is made with some spacing device or separator which prevents contact between adjacent balls.

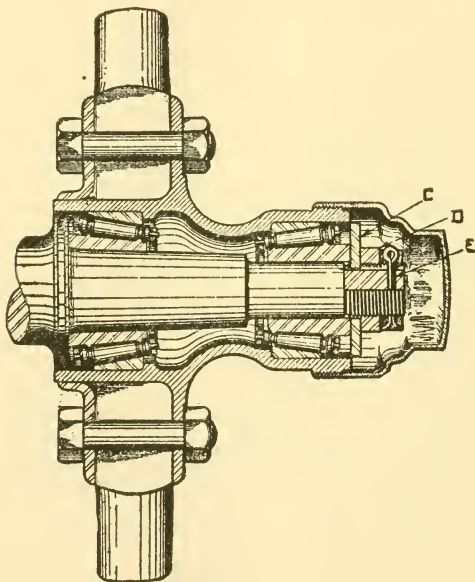

Fig. 252.—Roller bearings as mounted on front hub of the Franklin car. They should be adjusted so that the wheels turn freely, but without side play. After adjusting, the cotter pin is inserted in the hole. The washer, C, goes on before the nut, D, to keep the latter from turning; it accomplishes this by means of a keyway in the spindle.

In one construction of the silent type, springs are interposed which are provided with felt pads for holding the lubricant.

Ques. What other form of ball bearing is used?

Ans. Sometimes two rows of balls are provided in one bearing.

Ques. Describe a "roller" bearing.

Ans. This consists of a series of hardened cylindrical or tapered rollers, held in position by a cage or "retainer," and in rolling contact with hardened steel casings. It is usual to include end thrust ball bearings at the extremities of the rollers, in order to still further reduce friction and wear.

Ques. How should cup and cone ball bearings be adjusted when replacing a wheel?

Ans. The adjustment should be made so that the wheel will turn perfectly free, because a tight bearing will crush the balls or damage the ball race.

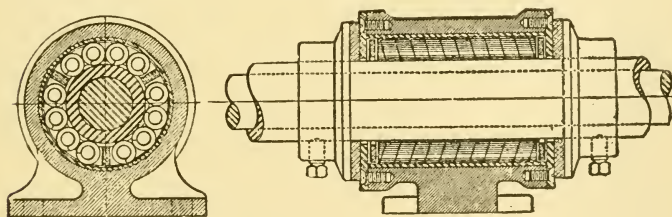

Fig. 253.—The "Hyatt" flexible roller bearing; this consists of strips of steel rolled into coiled springs, forming a strong, though elastic support, and capable of taking some end thrust.

Ques. What kind of lubricant is suitable for ball bearings?

Ans. Oil or grease that is not too heavy or solid. In general, the most fluid lubricant, not thinner, than the heavier machine oils, that can be satisfactorily retained is the best. A grease containing solid matter should not be used.

Ques. What kind of lubricant is suitable for roller bearings?

Ans. The same as for ball bearings, except the thicker grease. A thick grease will prevent the free rotation of the

rollers, and may have a tendency to throw them out of alignment with the journal.

Ques. What are the indications of wear in a ball bearing?

Ans. The races become rough by flaking off of the skin of the metal, and the same effect may be noticeable on the balls. If the races be not sufficiently hardened, they may groove without flaking.

LUBRICANTS AND LUBRICATION

One of the important considerations in connection with the operation of an automobile of any power, relates to the proper lubrication of the moving parts. As is evident on reflection, it is necessary that all such parts should be supplied with oil or lubricating grease, but it is also a fact, not so well understood, that different kinds of lubricant are necessary for the different parts of the car.

With the ordinary oils, suitable for use in the steam engine cylinder, it was impossible to obtain anything like a satisfactory speed and power efficiency, and only when the superior properties of mineral oils were better understood was the present high degree of perfection obtainable.

Answers Relating to Lubricants

Ques. What is the duty of a lubricant?

Ans. The duty of a lubricant is to reduce friction; the lubricant accomplishes this by keeping the parts separate, being pressed out into a thin film on which the moving parts rub, thus preventing direct contact.

Ques. Why is direct contact objectionable?

Ans. Because metal surfaces, although they appear smooth to the eye and to the touch, are made up of minute irregularities which are visible when magnified, as shown in fig. 254.

Ques. How do these irregularities act?

Ans. When two metal surfaces are brought into contact, these minute irregularities interlock, retard the motion, and tear off the projecting particles.

Ques. What term is applied to the tearing off of small metal particles?

Ans. Wear; when a bearing is allowed to **run dry**, the wear will often result in the piling up of such loose particles,

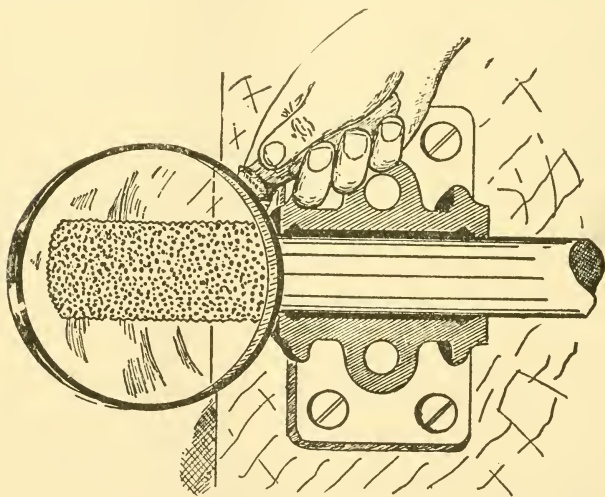

Fig. 254.—Imaginative view of a shaft showing its rough granular structure. In operation, these minute irregularities interlock and act as a retarding force, or frictional resistance. Hence, the necessity for lubrication—a lubricant presents a thin intervening film against which the surfaces rub.

which, due to pressure and the resulting heat, are again welded together, forming irregular humps on one of the surfaces, which cut grooves into the adjoining surface. This is usually termed **cutting** or **grooving**.

Ques. What is the final effect of cutting?

Ans. If not remedied in time, it will result in **freezing**, that is, the adhesion of the surfaces to each other.

Ques. What are the essential requirements of a lubricant?

Ans. 1, body, 2, fluidity or viscosity, 3, freedom from gumming, 4, absence of acid, 5, stability under temperature changes, and 6, freedom from foreign matter.

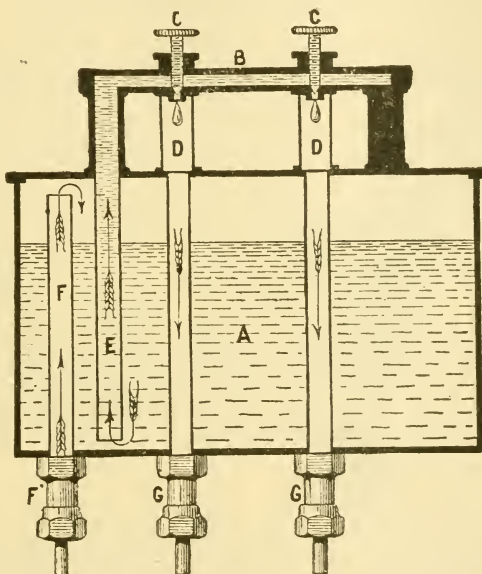

Fig. 255.—Typical force feed lubricator, operating by air or gas pressure instead of a pump. The parts are: A, oil reservoir; B, distributing pipe; C, C, valve screws for regulating flow of oil to parts, through leaders, D and D; E, standpipe through which oil is forced by air pressure; F, standpipe admitting air or exhaust gases under pressure; F', union for pipe from crank case; G, G, unions for pipes to various parts of the machinery.

Ques. What is meant by “body” of a lubricant?

Ans. The body indicates a certain consistency of substance, that prevents it being entirely squeezed out from the rubbing surfaces. The body of a lubricant should be such as to prevent a too rapid running off, depending on the working pressure.

Ques. What is understood by fluidity?

Ans. Fluidity of a lubricant refers to a certain lack of cohesion between the different particles, which reduces the fluid friction. Fluidity, so far as it does not oppose body, is a desirable quality. Excessive fluidity allows the lubricant to run off too quickly, thus causing waste.

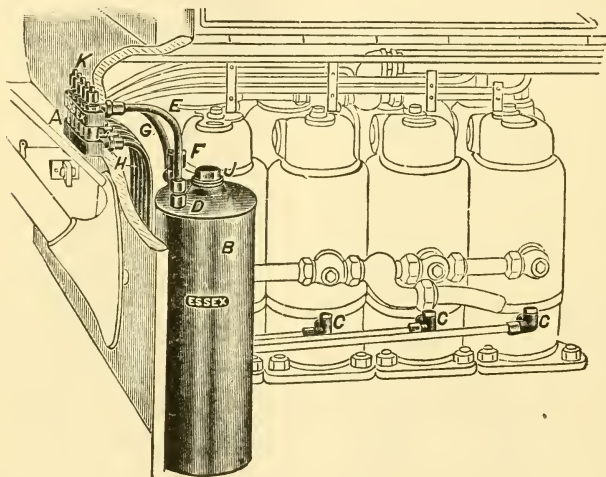

Fig. 256.—The Essex multi-feed automatic oiler. The sight feeds are attached to the inside of the dash, with their fittings extending through same; the reservoir is attached to the dash under the hood and piped to the engine as indicated. The parts are: A, sight feed fitting; B, reservoir; C, check valve for cylinder; $\frac{1}{4}$ " connection to oil tube; E, oil tube from reservoir to sight feed; F, pressure check; G, pressure tube; H, oil delivery tubes; J, filler plug; K, regulating valve stem.

Ques. What is stability of a lubricant?

Ans. A lubricant is said to be stable when it retains its good qualities under temperature changes.

Lubricants should retain their good qualities even when used under high temperature, as in the cylinder of an engine, or when used under low temperature, as in exposed bearings.

The lubricant should not evaporate or be decomposed by the degree of heat to which it will be exposed under working conditions. It must retain its normal body and fluidity as much as possible, and must not congeal by cold.

Ques. How are lubricants classified?

Ans. As solid or liquid.

Ques. How are they classified with respect to composition?

Ans. As animal, vegetable, or mineral.

Ques. Name the solid lubricants.

Ans. Graphite, soapstone, and the various lubricating greases.

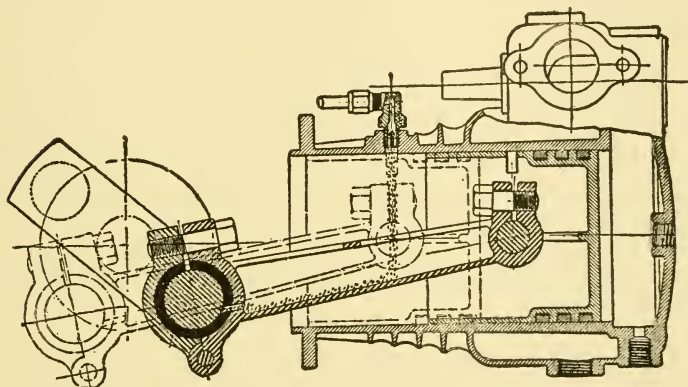

Fig. 257.—Horizontal cylinder oiled by force feed oiler distributor. The piston is oiled when passing under oil port, as shown by the dotted outline. The connecting rod is longitudinally grooved on the upper surface, so as to carry oil to the bearings.

Ques. What is graphite?

Ans. Graphite is one form of carbon; it has an iron gray color and metallic luster. Graphite is soft and unctuous to the touch, and is known also as black lead and plumbago.

Ques. In what two forms is graphite used?

Ans. In the crystalline or flake, and the powdered form.

Graphite is also known as **black lead** and **plumbago**. **Black lead** usually refers to inferior grades of graphite.

Ques. Is graphite used in its pure state only?

Ans. It is sometimes mixed with oil or grease, and in such combination makes an excellent lubricant.

Ques. Can graphite be used in the cylinder of an engine?

Ans. Yes; on account of its ability to withstand high temperatures, it makes a desirable lubricant for the cylinder. It fills up the pores of the metal, and forms a smooth surface, reducing friction, and tending to prevent leakage past the piston.

Ques. How is graphite applied to the surface of a cylinder?

Ans. In various ways; some prefer to mix it with oil in the form of a paste, and open the cylinder to apply the paste to the cylinder walls. It may also be introduced through the spark plug opening at intervals, or through a regular cup made for the purpose.

Graphite should be used moderately, as it is a conductor of electricity, and if the spark plugs become fouled with it, trouble will result.

Ques. How is soapstone used?

Ans. Soapstone is used in the form of a powder or mixed with oil or grease. It should, however, be used sparingly, especially when mixed with oil, as it may clog the oil grooves of a bearing.

Ques. What may be said about the use of grease?

Ans. The various lubricating greases are well adapted for heavy pressures under slow speeds, they are generally fed to the bearing under pressure of a spring compression grease cup or a screw compression cup. The lubricating qualities are often improved by mixing with graphite.

Ques. Where is grease especially desirable?

Ans. On the crank shaft bearings of a two cycle engine, as on account of its consistency it will not run out, hence, it will

make the bearings tighter against leakage of crank case compression.

Ques. What are liquid lubricants?

Ans. The various grades of oils.

Ques. How are oils classified with reference to body?

Ans. As light or heavy.

Ques. How are oils classified as to their origin?

Ans. As animal, vegetable, or mineral.

Answers Relating to Oil Tests

Ques. What are the two kinds of oil tests?

Ans. Chemical and mechanical.

The former are usually made in laboratories, but there are a number of simple tests which any one can make.

Ques. What is meant by the **cold point** of an oil?

Ans. The cold point is the temperature at which any given grade of oil will freeze, or become cloudy.

Ques. What is the **flash point**?

Ans. The temperature at which an oil gives off inflammable vapors.

Ques. What is the **burning point**?

Ans. The temperature at which an oil takes fire.

Ques. Describe a test for clearness.

Ans. A sample of the oil is taken from a barrel that has been well rolled and shaken. The glass containing the sample should be transparent, and the oil, if very cold, should be warmed. The oil then, if of good quality, will be clear.

The amount of suspended matter is, with a light oil determined by mixing and shaking with a relatively larger quantity of gasoline.

Ques. How is the purity of an oil indicated?

Ans. By shaking a small quantity in a bottle with a quick, jerking motion, so as to produce air bubbles. If the oil be pure, the bubbles will soon burst and disappear, but if mixed with other oils, they will rise to the surface and collect.

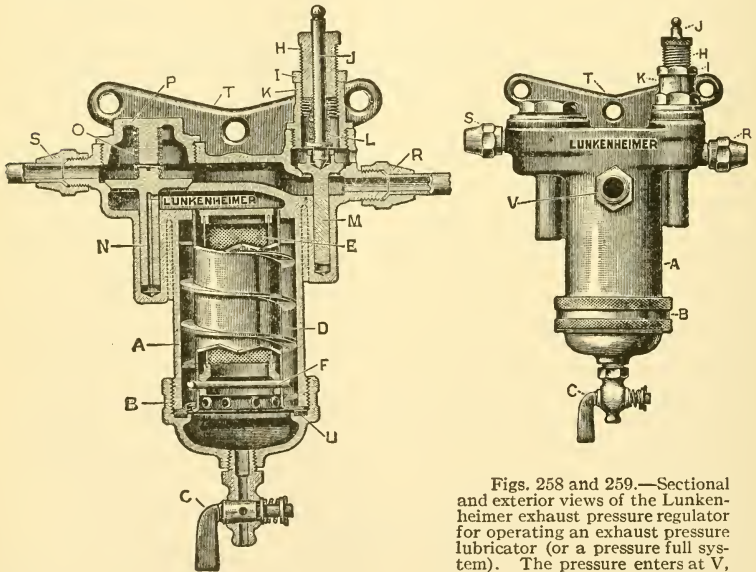

Figs. 258 and 259.—Sectional and exterior views of the Lunkenheimer exhaust pressure regulator for operating an exhaust pressure lubricator (or a pressure full system). The pressure enters at V, passes around tube D through the spiral passage, then through holes

at bottom of tube D into the strainer chamber, through the fine gauze strainer E, past the check valve N; from here the pressure is led to the exhaust pressure lubricator, and also through a separate connection to pressure gauge, mounted on the dash. M is a spring relief valve which may be adjusted to maintain any pressure desired, from 2 ounces to 4 pounds. The spiral arrangement, around which the incoming gas passes, serves to cool and purify the gas and condense moisture. The water of condensation collects in the large aluminum cap B, where it can be drained off at will. The fine mesh strainer is provided to screen the gas and remove remaining particles of carbon. The spiral tube and the strainer may be removed for cleansing, by unscrewing the knurled cap B. The pressure is increased or decreased by adjusting the regulating screw H.

Ques. How may animal matter be detected in oil?

Ans. About one oz. of the oil is placed in a 4 oz. bottle, and two teaspoonfuls of powdered borax. If, on shaking, a soapy deposit should form, the oil contains animal matter.

Ques. Describe the acid test.

Ans. A small quantity of oil is mixed with warm water or alcohol, and tested with blue litmus paper, which will turn red if any free acid be present.

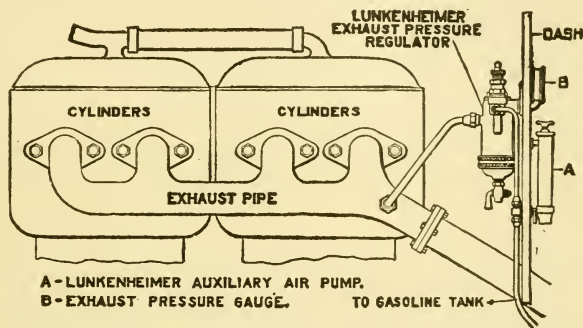

Fig. 260.—The Lunkenheimer exhaust pressure regulator as applied to an automobile. The purpose of this device is to automatically control the pressure of the exhaust, so that it may be utilized either to operate an exhaust pressure lubricator, or to force gasoline from the main to the auxiliary tank of a pressure fuel system.

Ques. What is the test for rancid oil?

Ans. Rancid oil is indicated by its odor when a few drops are rubbed between the hands.

Answers Relating to Lubricating Systems

Ques. Name several methods of engine lubrication in general use.

Ans. The gravity, splash, pressure and positive systems.

Ques. Explain briefly the working principle of each system.

Ans. 1, in the gravity system, the lubricator is placed at a sufficiently high elevation to permit the oil to flow to

the bearings; 2, in the **splash system**, a quantity of oil is placed in the crank case and maintained at such a level that the ends of the connecting rods come in contact with the oil at the lower part of their revolution and splash it upon the working parts; 3, in the **pressure system**, the oil is contained in a reservoir and forced to the various bearings under pressure acquired by connecting the reservoir to the exhaust by a small pipe, or by utilizing the pressure from an enclosed crank case; in the **positive system**, a pump geared to the engine forces a certain amount of oil through the feed at each stroke of the plunger.

Ques. How is a gas engine cylinder lubricated?

Ans. In some engines the splash system is used, while in others the oil is fed from a lubricator.

Answers Relating to the Choice of a Lubricant

Ques. What determines the choice of a lubricant?

Ans. The principal things to be considered are: 1, rubbing pressure; 2, rubbing velocity, and 3, temperature.

Ques. How should oil be selected for cylinder lubrication?

Ans. It is desirable to select an oil that will deposit as little carbon as possible.

Ques. Are animal oils suitable for engine lubrication?

Ans. Animal oils, such as sperm, whale, fish, lard and neat's foot oils are sometimes used on outside bearings of heavier machines, but for high speed machinery especially gas engines, with the accompanying high temperature, they should not be used.

Ques. What kind of oil is generally used for engine lubrication?

Ans. Mineral oil of considerable body yet of high fluidity and cold point.

Ques. What qualifications must a cylinder oil possess?

Ans. It should have a "flash" point of not less than 360° Fahr., and a fire test of at least 420° , together with a specific gravity of 25.8, and a viscosity of 175.

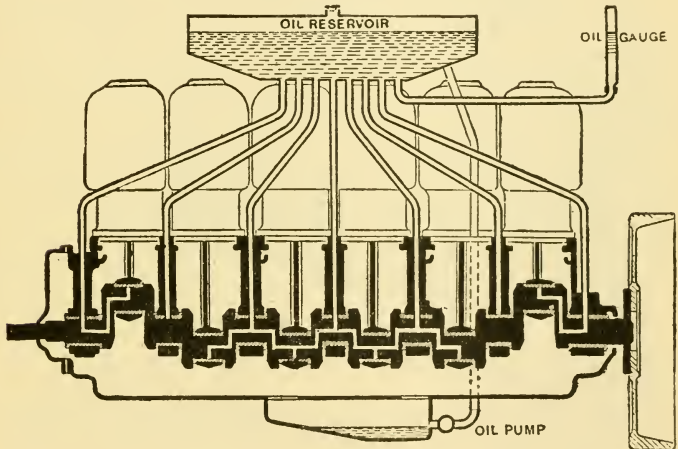

Fig. 261.—Sectional view of the Pierce lubricating system, showing the position of the oil reservoir relatively to the bearings to which it transmits the lubricating fluid and the connection by which the overflow is returned to the reservoir.

Ques. Why must the oil have a high flash point?

Ans. As the piston rises in the cylinder, the oil is deposited on the walls; when the piston moves outward the oil is exposed to the heat of the burning gases. The length of time during which it will continue to lubricate under this condition will determine the value of the oil.

Ques. Are vegetable oils suitable for lubrication?

Ans. They are used on outside bearings to some extent.

Ques. Is it customary to use any other than mineral oil on the bearings?

Ans. As most automobile engines are oiled from a common lubricator, only one grade of oil is used, and this is selected to suit the cylinders. Oils that are suitable for gas engine cylinders are suitable for the other bearings.

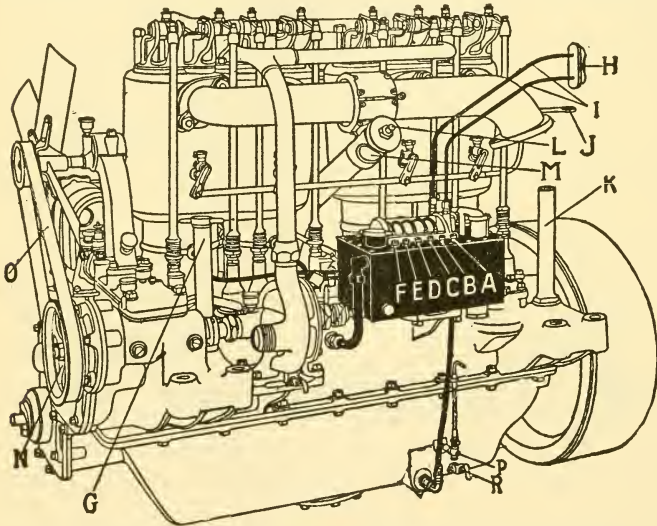

Fig. 262.—Splash and force feed lubrication system as applied to the Pope-Hartford engine. The force feed oiler is bolted to the crank case and driven by an extension of the water pump shaft. The oil supply is drawn from a reservoir in the bottom of the crank case. This oil, less the amount delivered by the small pumps through the six feeds, F, E, D, C, B, A, passes through an overflow pipe, B, into the cam shaft chamber of the crank case, lubricating the cam shaft bearings, cams, rollers and holders. From here the oil is led through holes so located as to always maintain the correct level in the cam shaft chamber, to each of the main bearings, thence it finds its way into and maintains a constant level in the crank pit for connecting rod lubrication and the general splash lubrication of the engine. The surplus oil overflows through a stand pipe and strainer, D, into the reservoir, from which it is again sucked up into the oiler and used again as above described. The crank case reservoir is filled through G; oil poured through this opening first fills the crank pit, then overflows through a stand pipe and strainer until it reaches the level of the gauge cock, H, being strained three times after leaving the crank case before being used again. The pipes, I, lead to sight feed, H, on dash; the cocks P and R indicate, respectively, highest and lowest levels.

Ques. How should a lubricant be selected to suit the rubbing pressure?

Ans. For heavy pressures, it should have a good deal of body, while for lighter pressures there should be less body.

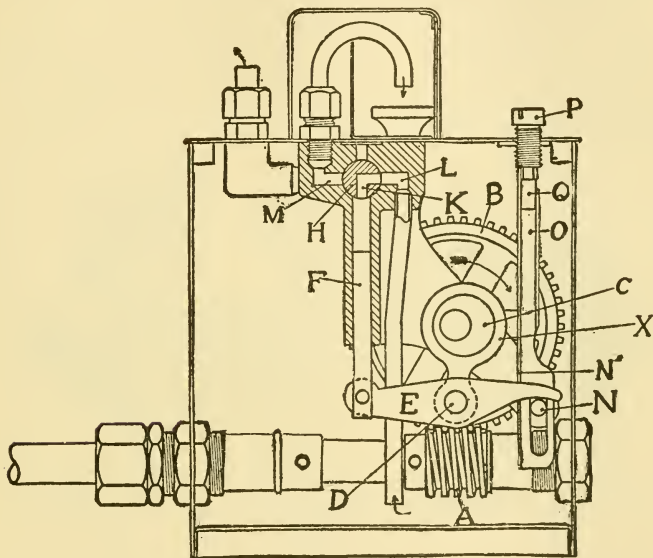

Fig. 263.—Sectional view of a mechanical oiler. By adjusting the screw P the quantity of oil pumped can be varied to suit the requirements. When screws are down the oiler is delivering its maximum capacity. The sight feed glasses on top of the oiler show the quantity of oil passing through each pipe, and under ordinary conditions about three drops to each stroke of the pump is an average supply. This oiler is filled through an opening on top, and the height of the oil in the reservoir is ascertained by a gauge glass at the end.

Ques. What quality is desirable, with respect to rubbing velocity?

Ans. For high speed bearings, a lubricant should possess good fluidity, while for low speed, less fluidity is desirable to prevent waste.

Ques. What kind of lubricant is suitable for the transmission gears?

Ans. Any lubricant of reasonable body that the gear case will retain gives good service.

The construction of some gear cases is such that good machine oil is retained and is satisfactory, while in others, grease must be used to prevent leakage. A combination of oil and grease is frequently put in gear cases; graphite mixed with oil is a very desirable lubricant for this purpose.

Ques. What should be used for the rear axle?

Ans. A compound of grease or graphite and oil, mixed to such a consistency that the gears will not simply cut a path in it, but it should be just liquid enough to flow.

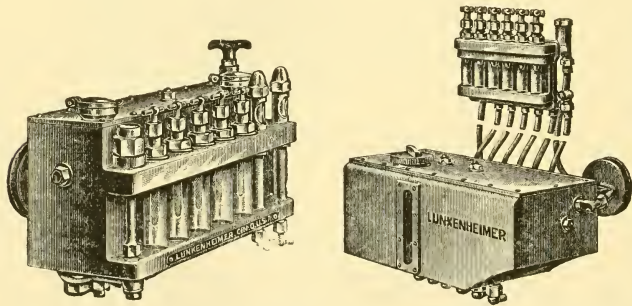

Figs. 264 and 265.—Lunkenheimer "Auto" multiple-feed mechanical lubricators. The illustrations show the integral and the independent manifold types. The one at the left has two compartments and a hand pump.

Ques. What attention should be given to the universal joint?

Ans. It should be packed with hard oil, and at frequent intervals lighter oil should be forced in, so that it will find its way to all the working joints.

Ques. What kind of lubricant is suitable for ball bearings?

Ans. Oil or grease that is not too heavy or solid. In general, the most fluid lubricant, not thinner than the heavier machine oils, that can be satisfactorily retained in the bearings, is most desirable.

Ques. What kind of lubricant is suitable for roller bearings?

Ans. The same as for ball bearings, except the thicker grease.

A thick grease will prevent free rotation of the rollers, and may have a tendency to throw them out of alignment with the journal.

The following lubrication schedule is here given as a guide for the proper lubrication of an automobile.

OIL EVERY DAY: 1, mechanical oiler, 2, starting crank bearing, 3, valve lifter tappets, 4, steering rod joints, 5, running or foot brake, 6, magneto spiral advance, 7, distributor spiral

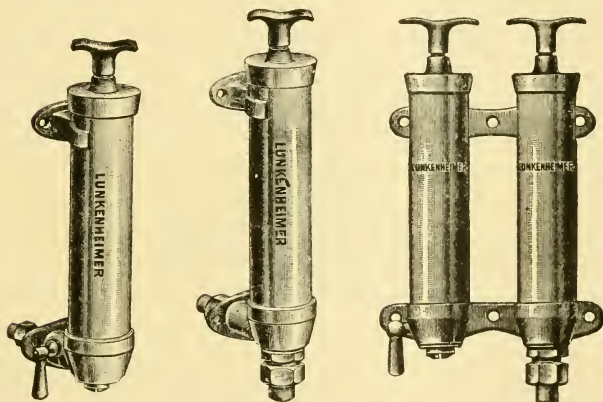

Figs. 266 to 268.—Air and oil hand pumps. The air pump, fig. 266, is used for creating pressure in the auxiliary tank to force the lubricating oil in the lubricator. The oil pump, fig. 267, is convenient for drawing oil from the lubricator or oil tank and forcing it into the crank case. For compactness both pumps are combined as in fig. 268.

advance, 8, grease cups, 9, inspect crank case level, 10, fill oil cups on rocker arms, 11, oil push rod bearings, and 12, oil inlet valve stems.

OIL EVERY 500 MILES: 1, inspect oil level in gear case, 2, control and break lever parts and bearings, 3, foot pedals, 4, steering gear case, 5, control lever bearings on top of steering wheel, 6, oiler drive and gear case bearings, 7, distributing bearings, 8, jack shaft universal joints, 9, magneto drive shaft bearings, and 10, universal clutch shaft joints.

OIL EVERY 1000 MILES: 1, steering axles, 2, springs, 3, gear shifting rods, 4, clutch parts, 5, compensating case, 6, forward

clutch ball bearings, 7, sprocket shaft ball bearings, 8, wheel ball bearings, 9, magneto, 10, fan bearings, and 11, clutch throw out yoke.

Ques. What is the effect of foreign matter in a lubricant?

Ans. Foreign matter increases friction and clogs the feed tubes, thus causing heating and consequent cutting.

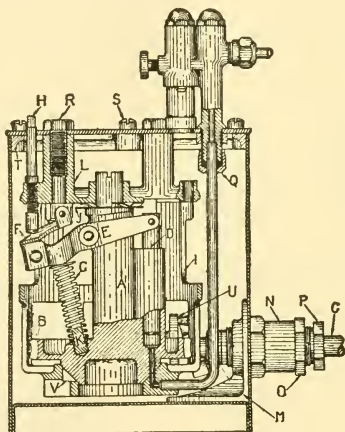

Fig. 269.—The Hill precision oiler. In operation, the center post A revolves by means of the worm wheel B, and the worm on the driving shaft C, which receives its motion from some part of the machine, either through a belt or ratchet. When the center post A is revolved, the plunger D is raised at intervals by means of the outer end of the yoke E, coming in contact with one of the cams F. Oil is thus drawn into the plunger chamber through port V. When the outlet to the chamber is in line with the delivery port, the yoke E disengages with the cam F and the spring G drives the plunger down, thus *shooting* the oil through the delivery pipe into the bearing. The amount of oil taken into the plunger chamber for any bearing is accurately proportioned by means of the adjusting screws H, each delivery tube having its own cam and adjusting screw. The center post is held firmly on its seat by means of the spring T.

Ques. What is the effect of grit?

Ans. Grit, such as road dust, or dust caused by sweeping the floor, etc., is about the worst substance that could enter the oil, its effect is to produce just what the oil is intended to prevent, namely, wear, heating and cutting.

Grit consists, to a large extent, of fine sand, that is, pulverized rock or quartz; these substances are very hard, and will have the same effect upon steel or other metals as emery.

MOTOR CYCLES

According to experience in the matter, a motor cycle must be propelled by an engine of rather high speed and of somewhat higher power rating than is actually required for the load to be carried. The reasons for both conditions are apparent, since, having dispensed with the water cooling and circulating system for sake of lightness and compactness, it is desirable to avoid overheating which might occur at high speeds, and such low power as would cause the engine to labor under ordinary loads.

Many autoists have begun motoring on motor cycles. It is a very useful and inexpensive way of becoming familiar with the operation and peculiarities of the gas engine.

Motor cycles, although much cheaper than automobiles, are capable of the same speed as the average car; moreover, the expense of fuel and upkeep is very small.

Answers Relating to Motor Cycles

Ques. What size engines are usually fitted to motor cycles?

Ans. From two to seven horse power; the latter is far in excess of demands for carrying one person over the average roadway.

Ques. What size engine is suitable for ordinary use?

Ans. About four horse power.

Ques. What may be said of the frame and wheels?

Ans. Both are made heavier and stronger than in foot propelled machines. The tubes are made with thicker walls, and the joints more securely reinforced. In several makes, the end of security is further assured by struts and trusses, particularly at the fork on the steering post and at the place where the engine is hung.

Ques. What types of engine are used on motor cycles?

Ans. The one cylinder four cycle engine is the type in general use, although two and four cylinder engines are used on the higher powered machines.

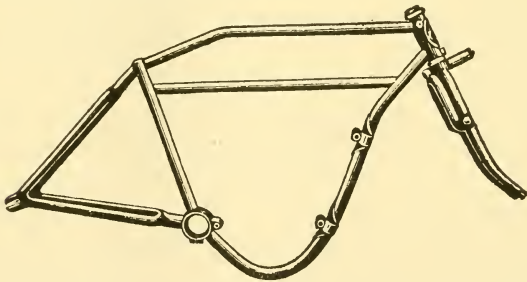

Fig. 270.—A motor cycle frame. The lower member is curved to conform to the shape of the crank case of the engine. The fork consists of two hinged pieces held in place by a spring forming a shock absorbing device.

Ques. What style of two cylinder engine is generally used?

Ans. The "V" twin cylinder engine, as shown in fig. 271; it is popular on account of its simplicity and lightness, there being only one crank and cam shaft for the two cylinders.

Ques. Where is the engine placed on the frame, and why?

Ans. It is located in a very low position, so as to keep the center of gravity low, and make the machine easy to balance. With this location, the rider does not have to

straddle a hot engine, and the air strikes directly on the cylinder head.

There has been a wide diversity of design in the location, and mode of attaching the engine to the frame. In some makes it has been supported on the back stays, between the pedal bearing and the rear wheel; in one make, on an extension of the back stays to rear of the wheel; in several makes it is supported against, or forms a part of the rear or saddle tube member of the "diamond" frame. The favorite position at the present time is on the forward part of the frame, in front of the pedal bearing, or on a tube arranged beneath, and suitably trussed to hold the weight.

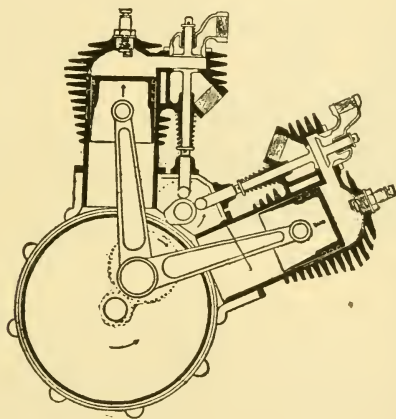

Fig. 271.—Sectional view of a "V" twin cylinder motor cycle engine. This type is in general use on the higher powered machines. Simplicity and lightness are secured in this design as one cam shaft and a single crank suffice for the two cylinders.

Ques. What cooling system is used?

Ans. Motor cycle engines are always air cooled.

Ques. How is the engine lubricated?

Ans. The splash system is employed; oil is placed in the crank case and the motion of the fly wheel and connecting rod end splashes it on the bearings, piston, and cylinder walls.

Ques. What is the usual arrangement of the valves and valve gear?

Ans. The valves are generally offset on one side of the cylinder, being arranged one above the other. The inlet valve is usually of the automatic type while the exhaust is always opened mechanically by a cam.

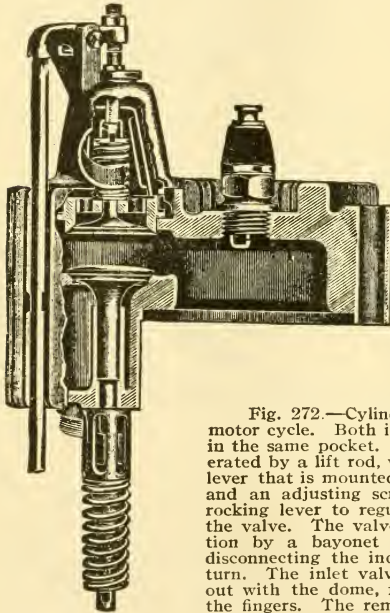

Fig. 272.—Cylinder head and valves of the Indian motor cycle. Both inlet and exhaust valves are placed in the same pocket. The inlet valve of the twin is operated by a lift rod, worked by the cam, and a rocking lever that is mounted on the dome of the valve chamber and an adjusting screw is provided in the end of this rocking lever to regulate the amount of the opening of the valve. The valve chamber dome is secured in position by a bayonet joint, and may be removed, after disconnecting the induction pipe, by giving it a quarter turn. The inlet valve, with its seat, spring, etc., come out with the dome, from which they are withdrawn by the fingers. The removal of the dome exposes the exhaust valve for inspection.

It is usual to fit the exhaust valve with a lifter to hold the valve off its seat and thus relieve compression in starting. This is operated by a conveniently located lever. A spiral spring effects the return of the lever to its original position.

Ques. What kind of ignition is generally used?

Ans. The high tension or jump spark.

Current is usually obtained from a battery of

three dry cells; on the multi-cylinder machines a magneto is frequently used. When a battery is used, a contact maker is provided for controlling the primary current.

The contact maker is attached to the cam shaft of the engine and the time of spark is regulated by rotating it around the cam shaft. Timing devices of this class are fully described in the chapter on ignition and the method of wiring illustrated in fig. 275.

The low tension wires may be distinguished by the small amount of insulation surrounding them as compared with the secondary or plug wires.

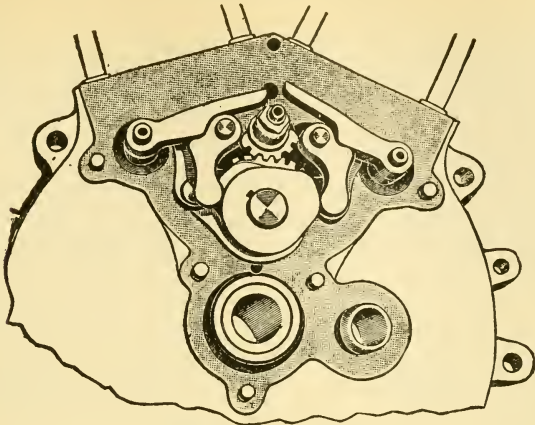

Fig. 273.—Valve gear of the Indian motor cycle. As shown in the illustration, the inlet valve of the front cylinder is about to close, while the exhaust valve of the rear cylinder has just opened. It will be seen that the revolving cam acts on the end of a cam lever, while the cam upon the lever lifts a second lever, or finger, upon which the lower end of the inlet valve operating rod rests. The exhaust valve is operated in the same way, but the levers are of slightly different form, and the end of the cam lever is provided with a steel roller to lessen the friction with the revolving cam, as the power required to operate the exhaust valve is greater than that required for the inlet valve.

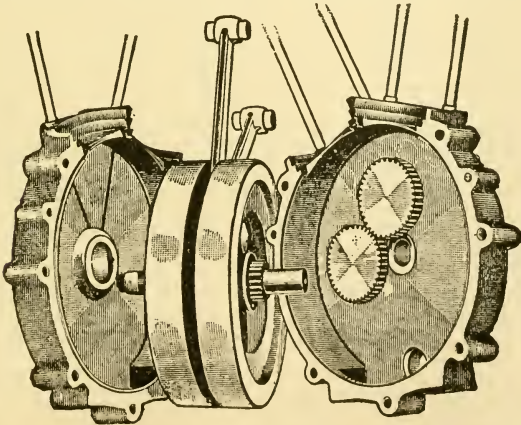

Fig. 274.—Interior view of a twin cylinder crank case with flywheels, connecting rods, and the two to one gears which operate the valve mechanism and the ignition apparatus, whether that be of the battery type or magneto. In this illustration an oil reservoir is shown and in the right hand half of the base is seen the little window through which the oil level can be observed.

Ques. What kind of primary circuit is used?

Ans. A ground circuit, in which the engine and frame form the ground return.

Ques. Describe the form of coil generally used.

Ans. The three terminal cartridge type of coil as shown in fig. 275. Where the terminals are not marked, it is easy to distinguish the high tension or secondary wire by its size,

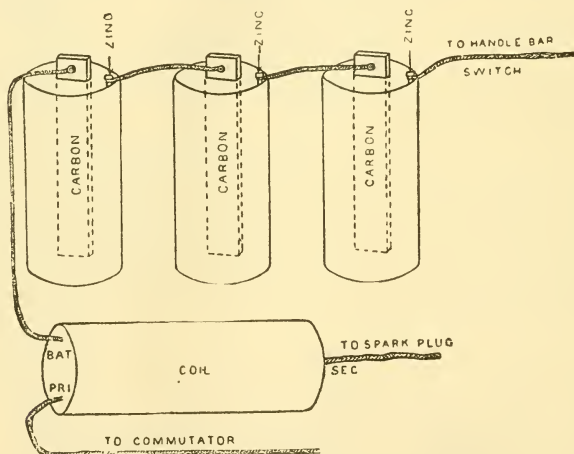

Fig. 275.—Diagram of battery and coil connections for jump spark ignition as applied to a motor cycle. Coils are usually plainly labeled with the abbreviations: "Bat.," "Pri.," "Sec.," indicating that the wires are to be connected to the battery, the primary circuit or contact maker, and the spark plug. The battery and primary wires being for the low tension circuit are easily distinguished from the secondary wire by the small amount of insulation surrounding them.

while almost without exception, the wires at the other end of the coil are to be connected to the battery and contact maker.

In a few cases, a four terminal coil is employed which, though apt to be confusing at first, need not complicate the matter of connecting it up in the machine if only it be remembered that the fourth terminal is a ground wire for the secondary coil, and should, therefore, be connected to some metal portion of the machine in a secure manner.

The method of connecting the wiring for multi-cylinder engines is exactly the same as it would be were each cylinder a separate engine in all respects, save that only one battery is used.

In wiring a multi-cylinder coil, then, it is necessary first to connect the proper terminal to the battery and to lead each of the primary wires to the proper terminals of the contact maker.

Ques. What kinds of jar absorbing device are used on motor cycles?

Ans. Some spring arrangement is included in the saddle post. In addition, a spring fork for the front wheel is usually provided.

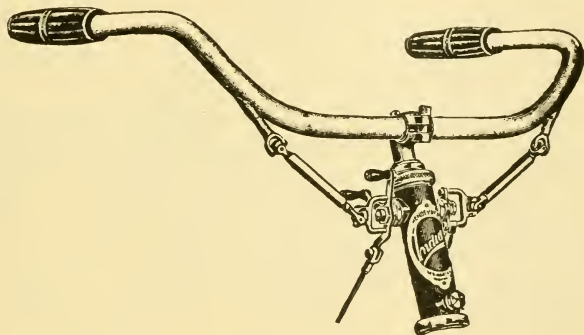

Fig. 276.—Handle bar grip control. A twist of the right wrist, operates the spark and exhaust valve. This controls the speed of the machine to a certain extent. When more speed or more power is required, a twist of the left wrist operates the throttle and applies the reserve power which is necessary when steep hills or sand roads are encountered.

Ques. What is the method of control?

Ans. The speed of the machine is usually regulated by adjusting or throttling the mixture and varying the time of the spark, also by cutting out the ignition so as to miss explosions.

Ques. What may be said with respect to timing the valves and spark?

Ans. With some types of engine, the timing of the valves and spark is fixed so that unless wrongly assembled at the

factory there is no chance of trouble excepting, of course, in the event of the rare but possible breakage of a tooth.

The gear teeth which mesh in order to give the correct movements are clearly marked either with lines on the ends of the gears or prick punch points, which in any case should be made to register when setting up the motor. Under these conditions the timing of the engine should be a comparatively easy task.

If for any reason it be desired to retime or to verify the timing independently, methods are illustrated in figs. 277 and 278, for performing these operations, and described in the text accompanying same.

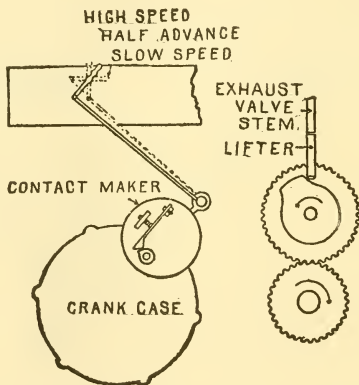

Fig. 277.—Timing motor cycle valves. After removing contact maker and gear case covers and the large gear, 1, the crank is placed on the upper dead center, and 2, the large gear and cam replaced, the large gear meshing with its driver in such a way that the cam is just breaking away from the lifter as shown in the figure. The gear case cover and contact maker are now replaced. The proper timing of the valve causes it to close on the dead center.

Fig. 278.—Usual arrangement for spark control on a motor cycle. To time the spark, 1, the spark lever is placed in such a position that the spark will be half way advanced, 2, the crank is turned through one revolution from the point of exhaust closure, 3, the sparking cam is set so that the contact spring is just leaving the contact screw, and tightened in this position.

Ques. What three kinds of drive are used on motor cycles?

Ans. The belt, the chain, and the shaft drive.

Ques. What objections are there to the belt drive?

Ans. It requires adjustment, and must be kept in tight contact to prevent slippage of the small driving pulley on

the engine; slippage results in loss of power. A belt deteriorates rapidly, due to moisture, dirt, etc., hence, it requires frequent repairs and renewals.

The use of the round, V-shaped and even flat belts, does not always give satisfaction. The great tension to which the belts have to be subjected in order to ensure proper adhesion, and still more the alternate action of dry and wet weather, cause them to stretch. This drawback frequently necessitates repairs on the road. Finally, the traction exercised by the belt on one of the ends of the hub, hinders the proper working of the latter.

Manufacturers have reduced considerably these defects by providing belts of larger and better form.

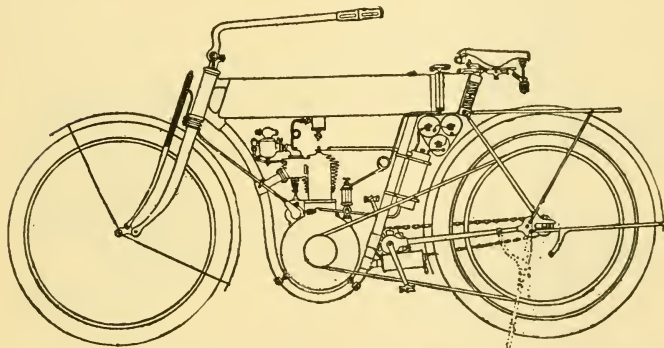

Fig. 279.—A belt drive motor cycle. As shown, the tension of the belt is adjusted by changing the position of the rear wheel axle. Another method of regulating the belt tension is by means of an adjustable idler pulley, illustrated in figs. 281 and 282. The above cut shows the general arrangement of the various parts, such as, carburettor, gasoline tank, ignition system, etc.

Ques. What may be said of chain, and shaft drives?

Ans. These types of drive furnish a positive connection between the engine and rear wheel. The chain drive is furnished on a number of the medium priced machines, and the shaft drive on the more expensive machines. While the chain is a satisfactory and inexpensive drive, the shaft with its enclosed gears is entirely protected from dust and does not present any lubricated surfaces to soil the rider's clothing.

Ques. Are transmissions used on motor cycles?

Ans. Yes; some are provided with a two speed and free engine transmission, others have in place of sliding gears a form of friction clutch by which the power may be gradually applied in starting.

Ques. What advantages are gained by the use of a transmission?

Ans. It enables the rider: 1, to climb steeper hills, 2, makes it possible to stop and restart at will without dismounting, either on level road or on the steepest hill, by

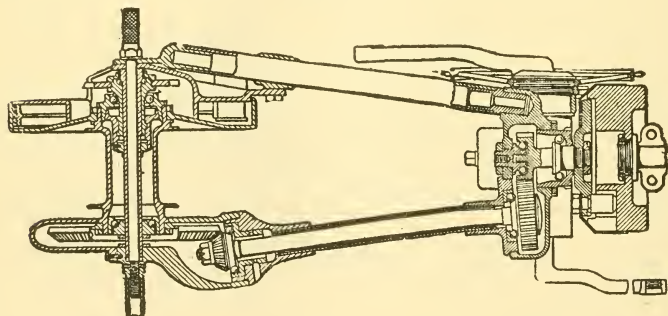

Fig. 280.—The F. N. shaft drive. It is operated as follows: Bringing the hand lever at the top of the frame tube into central position or upright, gives the neutral position allowing engine to run free; by pulling the lever backward, the low gear is obtained; by pushing the lever forward the low gear is disengaged and the high gear is brought into action. Two brakes are incorporated in the transmission.

means of the free engine, 3, to slow down or even come to a dead stop, if "pocketed" in a congested street, and 4, restart without pedaling.

Ques. In operating a motor cycle, what should be done before starting?

Ans. As a preliminary to starting: 1, the various parts of the machine should be carefully examined, 2, the gasoline tank and lubricating devices filled, 3, gasoline valve opened,

4, carburetter primed and throttle opened, 5, the exhaust valves raised, 6, ignition cut out plug inserted, 7, handle bar ignition switch opened, and 8, spark well advanced by means of the lever provided for the purpose.

Ques. Describe the proper method of starting.

Ans. In mounting the machine, the pedal on the left should be in the upper position. With right foot on the

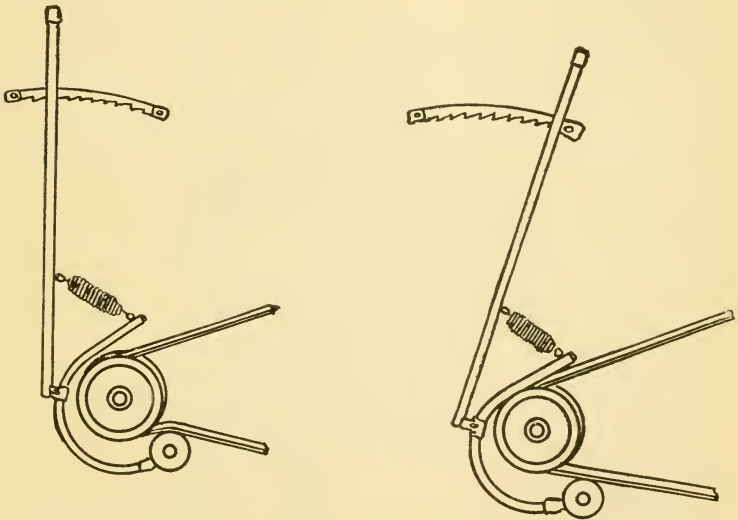

Figs. 281 and 282.—Illustrations showing the operation of a belt drive. The tension of the belt is regulated by the adjustable idler, the two cuts showing the "on" and "off" positions of the latter. The location of the idler in close proximity to the pulley, causes it to be more fully embraced by the belt, increasing the traction area without unduly increasing the belt tension.

ground, the machine standing, the rider straddles the saddle and starts the machine by pressure of the left foot on the raised pedal. This method requires less effort than taking a running start or mounting by rear step. After sufficient momentum has been obtained, the handle bar ignition switch should be closed, and the exhaust valve lifter released.

Ques. What adjustments should be made while riding?

Ans. As soon as the engine begins to operate, the spark should be retarded and adjusted together with the throttle to meet the speed requirements.

On motor cycles, as a rule, the speed is varied chiefly by the spark position. The control of the machine, at slow speeds, is made more flexible by the use of the handle bar ignition switch.

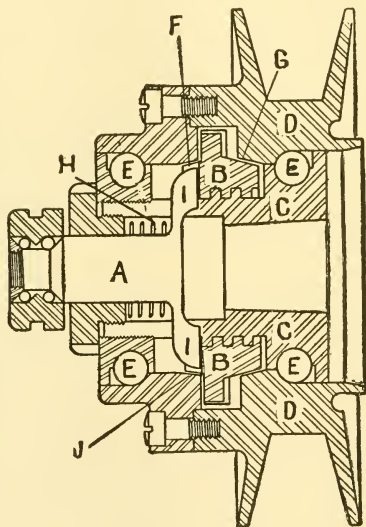

Fig. 283.—Emblem free engine pulley. The clutch block B is shown in idle or coasting position. To connect the pulley D with the drive shaft or screw C the locking pin A is withdrawn from the slot F in the nut B permitting the nut B to shift over against clutch face G on pulley D and causing all parts to revolve together. To disconnect the pulley from the shaft or screw C the locking pin A is released or thrust inwardly by the coil spring H against the face of the nut B where it remains until the differential speed of the shaft and pulley cause the nut B to shift back into the intermediate position again at which position the slot F is in line with the projections I on locking pin A. To start the engine, the operator after pedaling withdraws locking pin A, permitting the nut B to engage with the clutch face J which cranks or starts the engine. As soon as the engine receives an impulse, nut B shifts over against clutch face G where it remains until such time as the speed of pulley D exceeds that of the shaft. The pulley and shaft are practically permanently connected until such time as the locking pin is thrust inwardly and engages in the slot F and arrests the nut B in the non-engaging position.

Ques. What should be done in coasting down a hill?

Ans. In descending a hill: 1, the ignition should be cut out with the handle bar switch, 2, throttle closed, and 3, exhaust valves lifted; the latter operation relieves the drag of the engine and admits fresh air to the cylinders, which has a tendency to keep the spark plug points clean and clear the cylinder of carbon deposits.

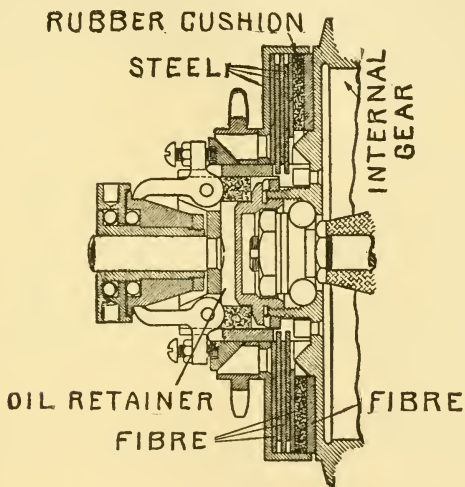

Fig. 284.—Minneapolis multiple disc friction clutch. A number of $5\frac{1}{2}$ -inch fibre discs act between polished steel discs, giving about 80 square inches of clutch surface. When the clutch is set, the discs are pressed together by two dogs or levers, acting upon a shifting cone, the cone in turn being connected to a control lever on the handle bar by a piano wire enclosed in a closely coiled spring.

Ques. What attention should be given to lubrication?

Ans. In operating a motor cycle, it is important that the lubrication of the engine receive frequent attention—say every ten miles. The crank case should receive sufficient oil that it may splash up against the piston and cylinder walls. Occasionally the crank case should be drained, washed out with gasoline, and a fresh supply of oil provided.

Ques. How should a stop be made?

Ans. When it is desired to stop: 1, the ignition should be cut out by the handle bar switch, 2, exhaust valve lifted, and 3, brakes applied.

Ques. What precaution should be taken when leaving the machine?

Ans. The gasoline valve should be closed, and the ignition plug removed to prevent the battery becoming exhausted if the machine should stop with contact maker on the spark position.

ELECTRICS

The term electric vehicle may be broadly applied to a great variety of either passenger or freight carrying machines which are propelled by electric energy supplied from either storage batteries or electric generators installed on the machines themselves.

The principal types of electric vehicle which are commercially successful are:

1. Electric automobiles, represented by various types of roadsters, coupés, phaetons, cabs, etc., suitable for the use of business men, physicians, and others, in city service.
2. Heavy electric trucks and vans for moving merchandise.
3. Gasoline-electric trucks, which represent an attempt to overcome the lack of flexibility of the internal combustion engine by combining it with a direct current generator and storage battery.

Answers Relating to Electric Vehicles

Ques. What type of motor is used on electric vehicles?

Ans. The form in general use is quite similar to railway motors, the overload capacity being quite large, as is necessary, to enable the vehicle to ascend steep grades, or negotiate heavy roads.

Ques. What forms of drive used?

Ans. The chain, herring bone gear, and shaft drive with bevel, or worm gear.

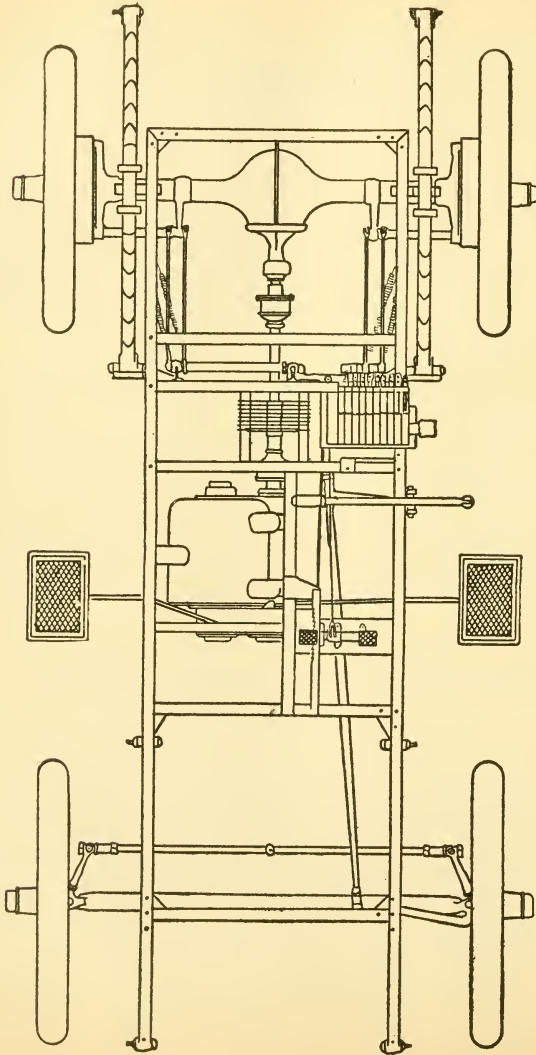

Fig. 285.—Chassis of Baker electric, showing shaft drive. The first speed reduction is by a short Reynolds silent chain in dust proof casing; power is transmitted to the wheels through the usual bevel gear at the rear axle.

Ques. Where is the motor usually hung?

Ans. Above the springs, to protect it from the jars of travel.

Ques. What are the general features of light electric vehicles?

Ans. These are of various types, such as roadsters, victorias, runabouts and coupés, and are equipped with batteries which have a capacity ranging from 75 to 100 miles per charge, with controller arrangements for providing speeds varying from 6 to 26 miles per hour. In these cases,

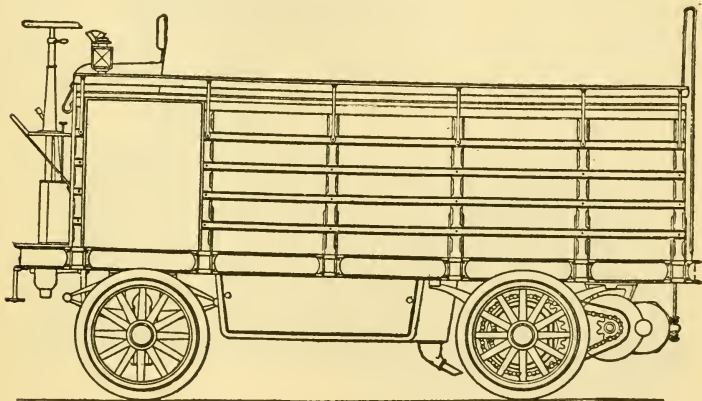

Fig. 286.—Chain and sprocket double reduction for heavy trucks. As here shown the motor is hung above the springs, missing the jars of travel.

the number of cells may vary from 10 to 30, according to the make and number of plates in each cell. The number of plates in each cell varies from 11 to 21.

Ques. What may be said of electric trucks for city service?

Ans. Under the conditions of traffic and street surface found in most large cities, the electric truck is quite satisfactory; the greater portion of city delivery is well within the limits of the safe operative mileage radius of the battery and the power sufficient for all ordinary demands.

Ques. What is a gasoline-electric vehicle?

Ans. An electric vehicle which is fitted with a dynamo and gas engine for charging the storage battery.

Ques. What is the object of this combination?

Ans. To overcome the inherent defects of gasoline or electric vehicles. The principal disadvantage of a gasoline vehicle is its lack of flexibility; while, on the other hand

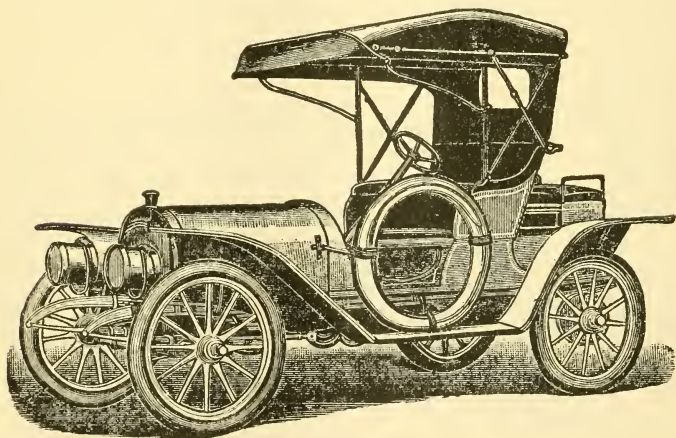

Fig. 287.—The Babcock electric roadster. This car is provided with a battery of forty-two cells, which it is claimed, gives one hundred miles at seventeen miles per hour on one charge. The controller provides for five speeds forward and two reverse. The motor develops fifteen horse power, which will run the car over thirty miles per hour.

the principal disadvantage of the electric vehicle operated by means of storage batteries is its lack of mobility. Hence, the shortcoming of each can be overcome by combining the two.

Ques. What are the objections to this type?

Ans. The arrangement involves considerable weight, complications and high first cost.

ELECTRICITY

The term electricity is derived from the Greek word **electron**—amber. It was discovered more than 2,000 years ago that amber when rubbed with an ox's tail possessed the curious property of attracting light bodies. It was discovered afterwards that this property could be produced in a dry steam jet by friction, and afterwards, that glass, sealing wax, etc., were also affected by rubbing, producing electricity.

Answers Relating to Electricity

Ques. What is electricity?

Ans. The name given to an invisible agent known only by its effects and manifestations, as shown in electrical phenomena.

Ques. Is there more than one kind of electricity?

Ans. Electricity, no matter how produced, is believed to be one and the same thing. The terms frictional electricity, magneto electricity, etc., though convenient for distinguishing their origin, have no longer the significance formerly attributed to them as representing different kinds of electric force.

Ques. How are the units of electricity expressed?

Ans. These are stated in terms of length, weight and time, which is to say in terms of centimeters, grams, and seconds. The units thus established are largely arbitrary,

but they have been carefully estimated, so that the proportions between current strength, circuit resistance and voltage may be accurately maintained.

Ques. What is an ohm?

Ans. The unit of resistance. It is named for G. S. Ohm, the German scientist, and is equal to the resistance offered to an unvarying electric current by a column of mercury at 32° Fahr., 14.4521 grams in mass, of a constant cross sectional area, and of the length of 106.3 centimeters.

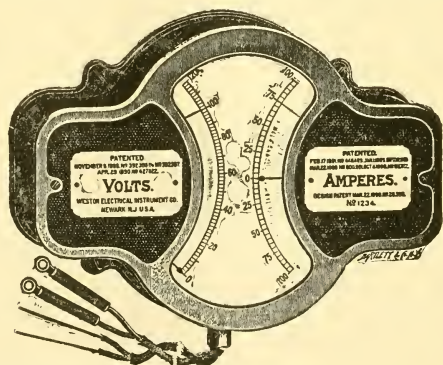

Fig. 288.—Western volt-ammeter of the type used on electric vehicles. Other makes have the index scales side by side, instead of end to end.

The ohm measures not only the relative resistance of a circuit composed of a conducting wire of a given length and diameter, as compared with wires of different lengths and diameters composed of the same material, but also the specific resistance, which refers to the variations in resistance found between given wires of the same length and cross section, made of different materials. The different resistivity of several different metals, as found in circuits of similar dimensions, is demonstrated by the fact that, while a unit wire of silver shows a conductivity of 100, and one of copper 99, a wire of iron gives only 16.80.

Ques. What is an ampere?

Ans. The unit of current. An ampere is the current produced by an electromotive force of one volt in a circuit

having a resistance of one ohm, it is that quantity of electricity which will deposit .005084 gram of copper per second.

Ques. What is a volt?

Ans. The unit of pressure or electromotive force. A volt is that electromotive force which can produce a current of one ampere on a circuit having a resistance of one ohm.

There are several specified equivalents for estimating the exact value of one volt E. M. F., but these usually refer to the determined capacity of some given type of galvanic cell. It is sufficient to say, however, for ordinary purposes, the majority of commercial chemical cells are constructed to yield approximately one volt. The ordinary Daniell cell used in telegraphy has a capacity of 1.08 volt, and the common type of Leclanche cell gives about 1.50.

Ques. What are the mutual relations between the ampere, the volt and the ohm?

Ans. The current in amperes equals the pressure in volts divided by the resistance.

Expressed as a formula:

$$\text{Amperes} = \frac{\text{volts}}{\text{resistance}}, \text{ or using the usual symbols}$$

$$C = \frac{E}{R} \dots \dots \dots (1)$$

from (1) is obtained

$$E = C R \dots \dots \dots (2)$$

$$R = \frac{E}{C} \dots \dots \dots (3)$$

If one volt will force one ampere of current through a circuit having one ohm resistance, it will take five volts to force five amperes through the same circuit. If this resistance be increased to five ohms, it would take five times five amperes for the proper number of volts to force the amperes through, which would be twenty-five volts. From this it can be seen that it is easy to obtain any one of these quantities when the other two are known.

Ques. What is a watt?

Ans. The unit of power. It is the rate of energy of one ampere of current under a pressure of one volt, and is approximately equal to $\frac{1}{746}$ horse power.

The watt derives its name from James Watt, the English engineer.

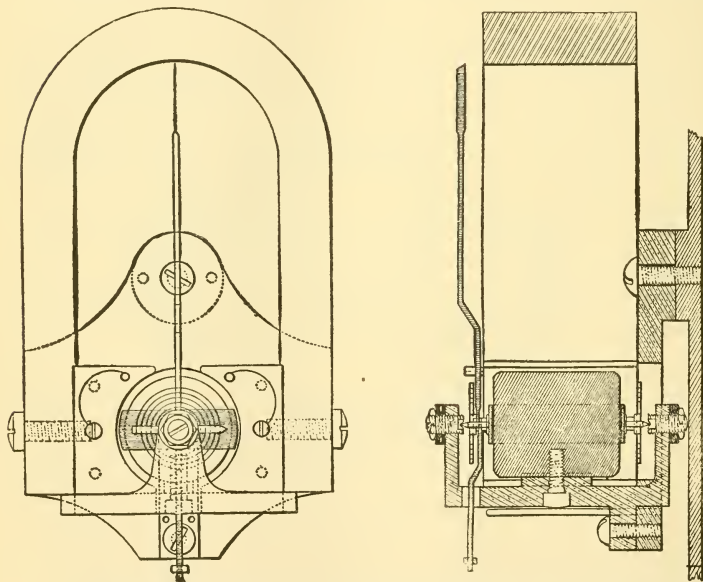

Figs. 289 and 290.—Sectional diagrams illustrating the construction of volt meters and ammeters. The iron core is secured to the base plate by a screw. The active coil is shown wound around it from end to end.

Ques. What is an electrical horse power?

Ans. The electrical equivalent of 33,000 foot pounds per minute or 746 watts.

To obtain the electrical horse power, as for instance the power developed by a motor, the product of the volts and amperes is divided by 746, that is,

$$\text{E. H. P.} = \frac{\text{volts} \times \text{amperes}}{746}$$

Ques. What is the general construction of volt meters and ammeters?

Ans. Electrical gauges for measuring volts and amperes are constructed on the principle of the D'Arsonval galvanometer, with either a permanent or a variable field. The general features are a small oscillating solenoid whose core is mounted on jeweled bearings, arranged like a dynamo armature between the poles of a permanent horseshoe magnet, with a hand or pointer pivoted at the bearing, so

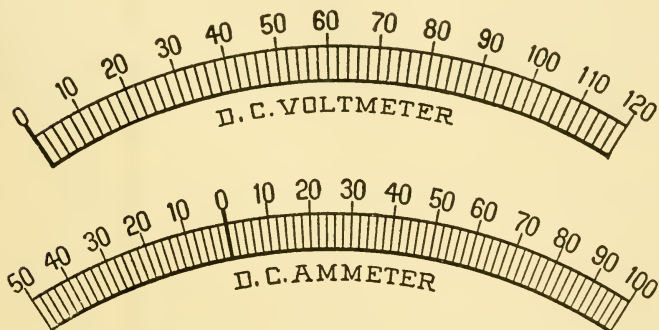

Fig. 291.—Index scales of a volt meter and ammeter for measuring the pressure and intensity of the current in a direct current electrical circuit.

as to indicate on a graduated scale the variation in electrical conditions. A coiled steel spring attached at the base of the needle acts to restrain and control its movements, thus ensuring reliable indications of current strength or intensity.

Ques. How are volt meters and ammeters arranged for automobiles?

Ans. They are usually mounted on one base, with their graduated scale cards sufficiently near together to enable rapid reading of battery conditions. These instruments frequently have the scale traced on glass, so as to be

illuminated at night by an incandescent lamp placed behind it. The voltmeter indicates the pressure between the battery terminals, while the ammeter indicates the amount of current flowing.

In running an electric vehicle, any overload that would likely damage the battery is indicated by the ammeter, when attempting to start with brakes set, or in beginning the ascent of a heavy grade from a standstill. The amount of power being consumed by the motor, is, of course, always the product of the volts by the amperes. Thus, with readings of 80 volts and 16 amperes, 1,280 watts, or about 1.7 horse power, are being constantly used.

Although the voltmeter should always register between 1.75 and 2.6 volts per cell, the former figure indicating the point of discharge—it may happen that an unusually heavy load will bring the needle temporarily below that point. Such indication does not of necessity mean that the battery is exhausted, as on coming upon a better road, it will quickly resume its normal reading.

DYNAMOS AND MOTORS

A dynamo is a machine for converting mechanical energy into electric current; a motor transforms the electric current into mechanical energy. The dynamo generator and the electric motor are similar so far as the general features of their construction are concerned. In operation, however, the motor is the reverse of the dynamo.

Answers Relating to Dynamos and Motors

Ques. What are the essential parts of a dynamo or motor?

Ans. The field magnets, pole pieces, armature, commutator or collector, and brushes.

Ques. What is the construction of the field magnets?

Ans. These are made like ordinary electromagnets, having two or any even number of opposed poles with their windings connected in series.

Ques. What are the pole pieces?

Ans. The steel end portions of the field magnets.

Ques. Describe the armature.

Ans. This consists of a metal core containing the shaft, and around which is a wire winding constructed to rotate near the poles of the field magnet.

Ques. Describe the commutator and brushes.

Ans. A commutator consists of copper bars or segments arranged side by side, forming a cylinder, and insulated from each other by sheets of mica. The commutator is mounted upon the shaft at one end of the armature with which it rotates. The conductors of the armature are so connected with the segments of the commutator that the current taken off by the brushes which bear upon the surface of the com-

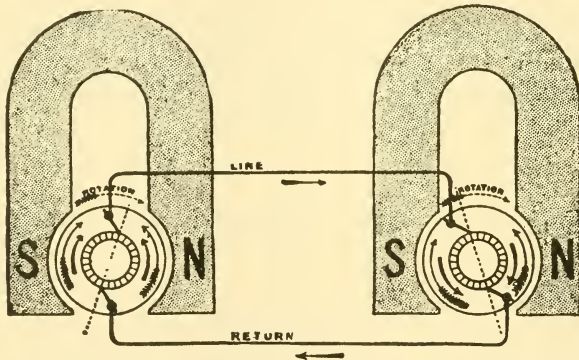

Fig. 292.—Diagram showing the operative condition of a dynamo generator and electric motor. The machine on the left is the dynamo, that on the right the motor.

mutator is direct, although the armature generates an alternating current.

Ques. What is the office of the brushes?

Ans. They bear upon the commutator and make sliding contact with the commutator bars, thus establishing the working circuits.

Ques. What type of motor is used on electric vehicles?

Ans. The kind known as series wound; this type possesses the valuable characteristic of automatically adjusting the consumption of power to the load.

Ques. How are shunt motors wound?

Ans. The field coils are on a shunt between the lead terminals.

Ques. How should the motor be operated on uneven roadway?

Ans. In hill climbing one-third and even more of the extra energy consumed can be recovered by coasting down the other side with the controller set a notch or two below the coasting speed.

While it is not necessary to be an electrician to operate an electrically driven vehicle, it is of great advantage to know what to do when certain troubles occur.

If an attempt be made to start with a single motor equipment, provided with a battery connected in different ways for the various speeds, and the vehicle and ammeter do not respond, this indicates an open circuit, which may be at one of the following points:

A. The battery contacts. They may be and often are so badly corroded as to prevent the necessary metal to metal contact.

B. The controller. A connection may be loose or the fingers may not make contact.

C. The running plug may sometimes be out or not making proper contact.

D. The motor brushes. May have dropped out or the tension may be so weak that they do not make contact.

E. The emergency switch may be open.

F. The controller should be examined last.

If the motor try to start, but the current is not sufficient, as shown by the ammeter, poor contact or weak battery may be suspected. Discharged battery will be indicated by a low voltmeter indication, but if the voltmeter indicate the normal amount, poor contact should be sought. Any contacts which are part of the electric circuit, such as binding

posts, brushes, switch jaws or controller fingers must be bright metal to metal contacts. If they be dirty or corroded the contact may be so bad that the flow of current is seriously reduced or interrupted altogether.

Answers Relating to Motor Troubles

Ques. What may be said respecting improper connections?

Ans. Sometimes the absence of ampere indication and no motion of the vehicle point to improper connection of the batteries. This will be shown by heavy sparks at the controller.

When the battery is not properly connected, the motion of the controller causes the sections of battery to exchange current between themselves at a ruinous rate. The terminals of the cells and those to which they should be connected ought to be plainly marked, or, better still, so constructed that it is impossible to go wrong. If the trouble just cited be the fact, one or more sets of terminals of the cells will be found to be connected to the wrong wires.

Ques. If the vehicle fail to move, and the flow of current, as indicated by the ammeter, be considerable, what should be done?

Ans. The current should be shut off at once, as serious damage may result if this be not done. It should then be ascertained if the brakes be on, the vehicle stalled or blocked, or if there be some obstacle between the gear teeth.

Ques. What may be said of short circuits?

Ans. If a large current be indicated, and the motor remain inert, the trouble is electrical, and the inference is that the current does not go through the motor at all. To confirm this, one of the motor brushes should be lifted, and the vehicle again tried. If the large current be still indicated, the inference of a short circuit becomes a certainty.

In locating a short circuit:

1. The controller should be examined for:

- A. Foreign pieces of metal making contact between portions of the electrical circuit.
- B. Loose fingers which may make contact with wrong parts of the controller or with each other.
- C. Dirt between the fingers or contacts.
- D. Breaks in the insulation permitting the wires to make contact with adjacent metal or with each other.

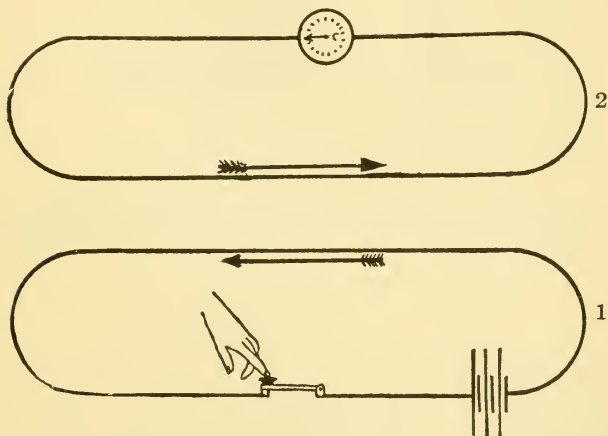

Fig. 293.—Diagram illustrating the action of voltaic induction between two circuits: the one including a source of electrical energy and a switch; the other including a galvanometer, but having no cell or other electrical source. The direction of the battery current in circuit 1 is indicated by the arrow; the arrow in circuit 2 shows the direction of the induced current.

2. The motor should be examined for:

- A. Broken insulation, allowing the bare wires to touch the frame or each other.
- B. Dirt between contacts or between live metal and the motor frame.
- C. Foreign materials bridging contacts.

In such a case, it is sometimes of assistance to turn on the current for an instant. The defective place may be indicated by a smoke or spark.

Ques. If, when a brush is lifted and the vehicle tried, the excessive current indication should disappear, what two electrical troubles are possible?

Ans. The magnet coils of the motor may be short circuited, or the ammeter may not be reading correctly.

The latter trouble is least likely; hence the former should be sought first.

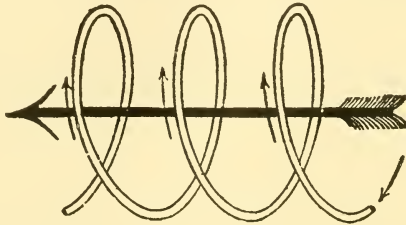

Fig. 294.—Diagram illustrating the directions of the current in the field windings and the induced current, as found in magnets, solenoids and dynamo operation.

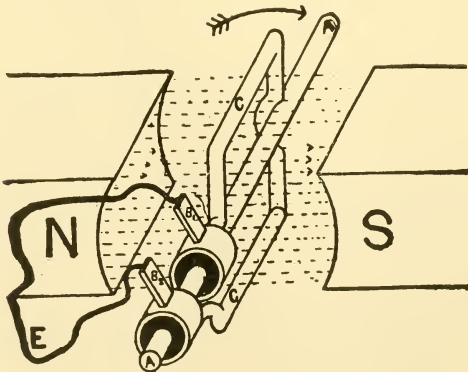

Fig. 295.—Diagram of a dynamo electrical generator, arranged for producing an alternating current, showing the constructional and operative features. Here N and S are the positive and negative poles of the field magnets, between which the lines of force are shown by the dotted lines. A is the armature spindle; B₁ and B₂, the brushes bearing on the ring drums; C, the coil or winding of the armature; E, the outside circuit to which the current is supplied.

Ques. What is the effect of a short circuited magnet coil of a series motor?

Ans. The motor will call for a large current but will do nothing with it. The magnet coils, therefore, should be examined for short circuits.

Ques. May a short circuit exist without ammeter indication?

Ans. Yes; a short circuit of this kind is usually found in the controller, which sparks heavily when operated,

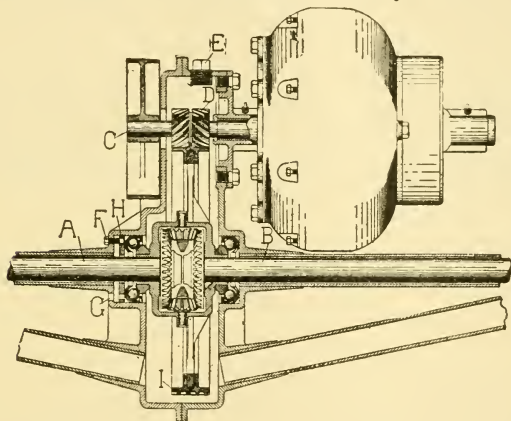

Fig. 296.—Diagram of a single motor attached to rear axle through "herringbone" single reducing gears. A, is the left hand section of the divided rear axle; B, the right hand section of the rear axle; C, the brake drum; D, the spiral pinion on the motor shaft driving the worm gear, I, on the differential; E, plug for greasing gears; F, set screw for locking ball race; G, slot for wrench to adjust threaded ring, H, against ball bearings.

although the vehicle does not move. This combination of phenomena also indicates improper connection of the batteries.

Ques. How is an excessive call for current indicated, other than by the ammeter?

Ans. A heavy current is accompanied with a drop in the voltmeter reading.

Ques. What may be said of two motor troubles?

Ans. Most difficulties which arise differ but little from those encountered with a single motor. A few which are

peculiar to this type may be mentioned. Such motors are sometimes run in two ways. The first notch connects the motors in series, while the higher speed notches connect the motors in parallel. If one of the motors open circuit on a series notch, the vehicle stops, for the entire motive circuit is broken. If it open circuit on a parallel notch, that motor stops and the other, with its circuit to the batteries intact, continues to run and may cause the vehicle to make some abrupt and unexpected turns.

If the accident occur in a series notch, the unimpaired motor continues to run, and, it may be added, at nearly double its previous speed. If it occur on a parallel notch, a short circuit on one motor constitutes a short circuit on the other also, and if the short circuit be sufficiently severe both motors will stop, even though an enormous current may be drawn from the batteries.

STORAGE BATTERIES

Storage batteries are devices for storing electric energy, which may be utilized subsequently for various purposes. The term accumulator is sometimes applied from the fact that they "accumulate" electric energy when charged from an outside source. Storage batteries are also called secondary batteries to distinguish them from those of the primary type.

Secondary batteries are in no sense generators of electricity, but are employed to accumulate a given quantity of electric energy, the quantity of which is estimated by the number of hours required to discharge it at a given rate.

Answers Relating to Storage Batteries

Ques. Describe the action of a storage cell.

Ans. Gautherot discovered that if two plates of platinum or silver, immersed in a suitable electrolyte, be connected to the terminals of an active primary cell and current be allowed to flow, a small current could be obtained on an outside circuit connecting these two electrodes, as soon as the primary battery had been disconnected.

Ques. Explain the process in detail.

Ans. An electrolyte, consisting of a weak solution of sulphuric acid, permits ready conduction of the current

from the primary battery; the greater the proportion of acid within certain limits the smaller the resistance offered. The effect of the current passing through the electrolyte is to decompose the water; this is indicated by the formation of bubbles upon the exposed surfaces of both electrode sheets, these bubbles being formed by oxygen gas on the plate connected to the positive pole of the primary battery and hydrogen on the plate connected to the negative pole of the battery. Since, however, the oxygen is unable to attack either platinum or silver under such conditions, the capacity of such a device to act as an electrical accumulator is practically limited to the point at which both plates are covered with bubbles. After this point has been reached the gases will begin to escape into the atmosphere.

Ques. What is the prime condition for operation in the simpler apparatus just described?

Ans. The resistance of the electrolyte should be as low as possible in order that the current may pass freely and with full effect between the electrodes. If the resistance of the electrolyte be too small, the current intensity will cause the water to boil rather than to cause the electrolytic effects noted above.

Ques. What happens when the charging current is discontinued, and the two electrodes joined by an outside wire?

Ans. A small current will flow as a result of the recombination of the acid and water solution. The process is in a very definite sense a reversal of that by which the current is generated in a primary cell. Hydrogen collected upon the negative plate, which was the cathode, so long as the primary battery was in circuit, is given off to the liquid immediately surrounding it, uniting with its particles of oxygen and causing the hydrogen in combination with them to unite with the particles of oxygen next adjacent,

continuing the process until the opposite positive plate is reached when the oxygen collected there is finally combined with the surplus hydrogen, going to it from the surrounding solution.

This chemical process causes the current to emerge from the positive plate, which was the anode, so long as the primary battery was in the circuit. The current thus produced will continue until the recomposition of the gases is complete, then ceasing because these gases, as before stated, do not combine with the metal of the electrodes.

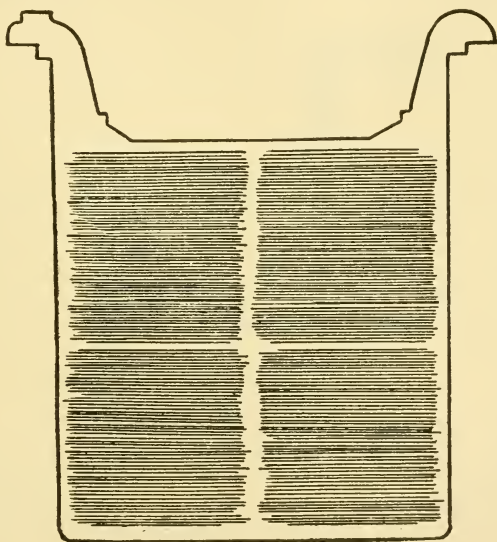

Fig. 297.—“Unformed” plate of one pattern of Gould storage cell. The particular plate shown has total outside dimensions of 6x6 inches. The clear outline of the grooves indicates absence of oxides, due to action of “forming” solutions, or charging current.

Ques. What material is used for the plates?

Ans. Batteries are manufactured with plates made of iron and nickel, lead and zinc, and lead and lead, the latter being extensively used. The choice of material depends largely upon the service required of the battery.

In lead batteries, the negative plates are made of sponge lead which has a light gray color and is very soft. The positive plates are of peroxide of lead, being dull chocolate in color and hard in texture.

Ques. Name two classes of storage battery.

Ans. The Plante, and the Faure.

Ques. What feature distinguishes the two types?

Ans. The difference is principally in the method of constructing the plates.

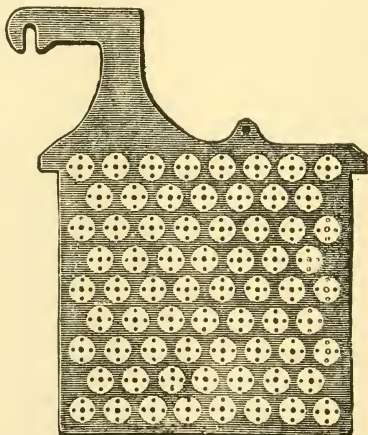

Fig. 298.—One plate or "grid" of a type of storage cell constructed by inserting buttons or ribbons of the proper chemical substances in perforations. Some such cells use crimped ribbons of metallic lead for inserting in the perforations, others pure red lead or other suitable material.

Ques. Describe the Plante type.

Ans. In the Plante type the lead is chemically attacked and finally converted into lead peroxide, probably after it has gone through several intermediate changes. The plates are all formed as positive plates first and then all that are intended for negative plates are reversed, the peroxide being changed into sponge lead.

Ques. What is done to make the Plante plate more efficient?

Ans. The surfaces are finely subdivided, the following methods being those most common: scoring, grooving, casting, laminating, pressing and by the use of a lead wool.

Ques. Describe the Faure or pasted type.

Ans. This form of plate is constructed by attaching the active material by some mechanical means to the grid proper. The active material first used for this purpose was red lead, which was reduced in a short time to lead peroxide when connected as the positive or anode, or to spongy metallic lead when connected as the cathode or negative, thus forming plates of the same chemical compound as in the Plante type.

The materials used at the present time by the manufacturers for making this paste are largely a secret with them, but in general they consist of pulverized lead or lead oxide mixed with some liquid to make a paste.

Ques. How do Faure plates compare with those of the Plante type?

Ans. They are usually lighter and have a higher capacity, but have a tendency to shed the material from the grid, thus making the battery useless.

Many ways have been tried for mechanically holding the active material on the grid, the general method involving a special design in the shape of the grid. Some of these designs are: 1, solid perforated sheets of lattice work, 2, corrugated and solid recess plates not perforated, 3, ribbed plates with projecting portions, 4, grid cast around active material, 5, lead envelopes, and 6, triangular troughs as horizontal ribs.

Answers Relating to the Electrolyte

Ques. What solution is generally used for the electrolyte of a storage battery?

Ans. It usually consists of one part of chemically pure concentrated sulphuric acid mixed with several parts of

water. The proportion of water differs with the several types of cell from three to eight parts, as specified in the directions accompanying the cells.

Ques. What test is necessary in preparing the electrolyte?

Ans. In mixing the water and acid, the hydrometer should be used to test the specific gravity* of both the acid and the solution. The most suitable acid should show a specific gravity of about 1.760 or 66° Baumé.

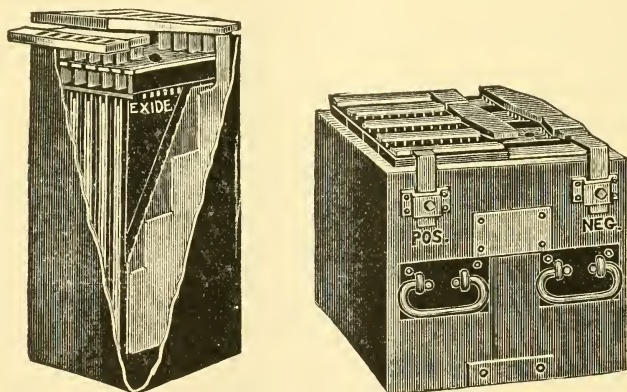

Fig. 299.—The Exide storage cell. The positive and negative plates are separated by thin sheets of perforated hard rubber, placed on both sides of each positive plate. The electrolyte and plates are contained in a hard rubber jar.

Fig. 300.—An Exide battery of five cells. The box which holds the cells is usually made of oak, properly reinforced, with the wood treated to render it acid proof. The terminals, as shown, consist of metal castings attached to the side of the box and plainly marked.

*Note.—Specific gravity is the weight of a given substance relative to an equal bulk of some other substance which is taken as a standard of comparison. Water is the standard for liquids. In the laboratory the *specific gravity bottle* is often used in determining the specific gravity of a liquid. The capacity of the bottle is 1,000 grains of pure water. When it is filled with spirits of wine and weighed in a balance (together with a counterpoise for the weight of the bottle, which of course is constant), it will weigh considerably less than 1,000 grains; in fact, the bottle will contain only about 917 grains of proof spirit; therefore, taking the specific gravity of water as unity, 1 or 1,000, the specific gravity of spirits of wine is 0.917. If, on the other hand, the bottle be filled with sulphuric acid, it will weigh about 1,850 grains; hence, the specific gravity of sulphuric acid is said to be 1.850. A more convenient method for the automobilist is by the use of the hydrometer.

Ques. How should the water and acid be mixed?

Ans. The mixture should be made by pouring the acid slowly into the water, never the reverse. As cannot be too strongly stated, it is **very dangerous to pour the water into the acid**; the latter is corrosive and will painfully burn the flesh.

Distilled or rain water should be used in preparing the electrolyte. When made, the solution should be allowed to cool for several hours or until its temperature is approximately that of the atmosphere (60° being the average). At this point it should have a specific gravity of about 1.200 or 25° Beaumé. If the hydrometer show a higher reading, water may be added until the correct reading is obtained; if a lower reading, dilute acid may be added with similar intent.

The electrolyte should never be mixed in jars containing the battery plates, but preferably in stone crocks, specially prepared for the purpose. Furthermore, it should never be placed in the cell until perfectly cool.

Answers Relating to Charging

Ques. What precautions should be taken in charging?

Ans. The connections with the generator should be properly arranged, that is, the positive pole of the generator should be invariably connected to the positive pole of the secondary battery, which is to say, the pole which is positive in action when the current is emerging from the secondary battery, or the pole that is connected to the positive plates. An error in making the connections will result in **entire derangement of the battery** and its ultimate destruction.

Ques. How should a battery be charged for the first time?

Ans. It is essential that the current be allowed to enter at the positive pole at about one-half the usual charging rate prescribed; but after making sure that all necessary conditions have been fulfilled, it is possible to raise the

rate to that prescribed by the manufacturers of the particular battery.

Ques. What portable instruments should be provided for testing batteries?

Ans. 1, a hydrometer syringe (specific gravity tester) 2, an acid testing set (can be used instead of the syringe), 3, a low reading voltmeter, 4, suitable prods, and 5, a thermometer.

Ques. What is the usual period for charging a new battery?

Ans. With several of the best known makes of storage battery, the prescribed period for the first charge varies between twenty and thirty hours.

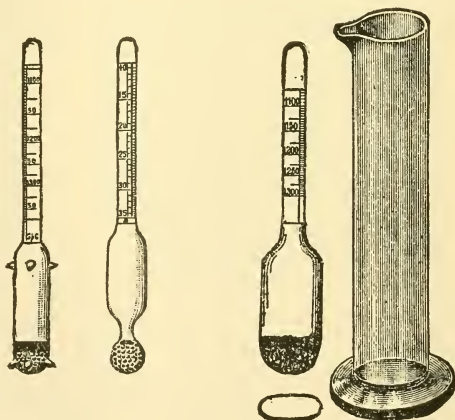
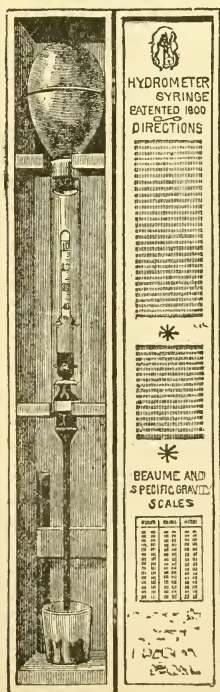

Figs. 301 to 303.—Acid hydrometers for liquids heavier than water. Fig. 301, standard storage battery hydrometer with guiding points designed for "hydrometer syringe," shot bulb, with red line at 25 Beaumé, 5 inches long, double scale 10 to 40 Beaumé, 1.050 to 1.400 specific gravity. Fig. 302, plain hydrometer with shot bulb, 5 inches long, double scale 10 to 40 Beaumé, 1.050 to 1.400 specific gravity. Fig. 303, hydrometer with small flat bulb, used in car lighting batteries, shot bulb $4\frac{1}{2}$ inches long, single scale, reading from 1.100 to 1.250 specific gravity. At the right is shown a jar for hydrometers.

At the first charging of a cell, when the pressure has reached the required limit, the cell should be discharged until the voltage has fallen to about two-thirds normal pressure, when the cell should again be recharged to the normal voltage (2.5 or 2.6 volts).

The manufacturers of a well known cell of the Plante genus prescribe for the first charge, half rate for four hours, after which the current may be increased to the normal power and continued for twenty hours successively.

Ques. What strength of current should be used in charging a cell?

Ans. It should be in proportion to the ampere hour capacity of the cell.

Thus, as given by several manufacturers and other authorities, the normal charging rate for a cell of 40 ampere hours should be fifty amperes; or one-eighth of its ampere hour rating in amperes of charging current.

Ques. What should be the voltage of the charging current before closing the charging circuit?

Ans. The voltage should be at least ten per cent. higher than the normal voltage of the battery when charged.

Ques. What indicates the completion of a charge?

Ans. When a cell is fully charged the electrolyte apparently boils and gives off gas freely. The completion of a charge may also be determined by the voltmeter, which will show whether the normal pressure has been attained.

Ques. How should the voltage be regulated during the first charge?

Ans. It should be allowed to rise somewhat above the point of normal pressure.

Ques. How often should a battery be charged?

Ans. At least once in two weeks, even if the use be only slight in proportion to the output capacity.

In charging a storage battery, it is essential to remember the fact that the normal charging rate is in proportion to the voltage of the battery itself.

Thus, a 100 ampere-hour battery, charged from a 110 volt circuit at the rate of ten amperes per hour, would require ten hours to charge, and would consume in that time an amount of electrical energy represented by the product of 110 (voltage) by 10 (amperes) which would give 1,100 watts.

Ques. What precaution should be taken in charging a battery?

Ans. Care should be taken not to have a naked flame anywhere in its vicinity.

To either charge or discharge a battery at too rapid a rate involves the generation of heat. Thus, while this is not liable to result in a flame under usual conditions, the battery may take fire, if it be improperly connected or improperly used.

Ques. How is the electrolyte affected by the first charge?

Ans. A change of specific gravity occurs. The specific gravity should be about 1.200 when the solution is first poured into the cells.

At the completion of the first charge, it should, on the same scale, be about 1.225. If it be higher than this, water should be added to the solution until the proper figure is reached, if it be lower, dilute sulphuric acid should be added until the hydrometer registers 1.225.

Ques. What is the effect of varying the charging current?

Ans. In charging a storage cell, particularly for the first time, a weaker current than that specified may be used with the same result, provided the prescribed duration of the charge be proportionally lengthened. The battery may also be occasionally charged beyond the prescribed voltage, ten or twenty per cent. overcharge effecting no injury, although, if frequently repeated, it shortens the life of the battery.

Ques. What are the charge indications?

Ans. The state of the charge is not only indicated by the density of the electrolyte and the voltage of the cell, but also by the **color of the plates**, which is considered by many authorities as one of the best tests for ascertaining the condition of a battery.

Ques. What are the colors of the plates?

Ans. In the case of formed plates, and before the first charging, the positives are of a dark brown color with whitish or reddish gray spots, and the negatives are of a yellowish

gray. The whitish or reddish gray spots on the positive plates are small particles of lead sulphate which have not been reduced to lead peroxide during the process of forming, and represent **imperfect sulphation**.

As a general rule, the first charging should be carried on until these spots completely disappear. After this the positive plates should be of a dark red or chocolate color at the end of the discharge, and of a wet slate or nearly black color when fully charged. A very small discharge is sufficient, however, to change them from black to the dark red or chocolate color.

If the battery has been discharged to a potential lower than 1.8 volts, the white sulphate deposits will reappear, turning the dark red color to a grayish tint in patches or all over the face of the plate, or in the form of scales of a venetian red color.

The formation of these scales while charging indicates that the maximum charging current is too large and should be reduced until the scales or white deposits fall off or disappear, after which the current can be increased again.

During charging, the yellowish gray color of the negatives changes to a pale slate color which grows slightly darker at the completion of the charge. The color of the negatives always remains, however, much lighter than that of the positives.

Ques. How is the discharge capacity of a storage battery stated?

Ans. In ampere hours. This, unless otherwise specified, refers to its output of current at the eight hour rate. Most manufacturers of automobile batteries specify only the amperage of the discharge at three and four hours. Thus, at the eight hour rate, a cell which will discharge at ten amperes for eight hours is said to have a capacity of eighty ampere hours. It does not follow that eighty amperes would be secured if the cell were discharged in one hour. It is safe to say that not more than forty amperes would be the result with this rapid discharge.

Ques. How does the capacity decrease?

Ans. The ampere hour capacity decreases with the increase in current output.

An 80 ampere-hour cell, capable of delivering 10 amperes for 8 hours, would, when discharged at 14 amperes, have a capacity of 70 ampere hours; when discharged at 20, its capacity would be

60; and when discharged at 40, its capacity will have decreased from 80 to 40 ampere hours.

Ques. What, in general, is the indication of the quantity of electricity remaining within a cell?

Ans. The voltage.

Ques. What should be noted by the operator in driving a car?

Ans. He should bear in mind the figures supplied by the manufacturers of the type of battery he uses, in order to judge: 1, how long the charge will last, and 2, whether

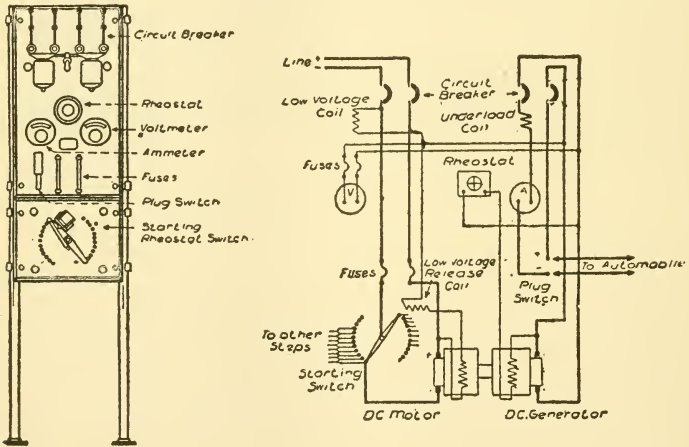

Figs. 304 and 305. Switchboard and motor generator circuit connections for charging a battery from direct current mains.

he is exceeding the normal rate of discharge, and thus contributing to the unnecessary waste of his battery and incurring other dangers that may involve unnecessary expense.

As a general rule, the one hour discharge rate is four times that of the normal, or eight hour discharge, and considerations of economy and prudence suggest that it should never be exceeded, if, indeed, it be ever employed. The three hour discharge, which is normally twice that of the eight hour, is usually the highest that is prudent, while the four hour discharge is the one most often employed for the average high speed riding; batteries give only the three and four hour discharge rates in specifying the capacity of their products.

consists of a direct current dynamo, driven direct from the shaft of a motor, which, in turn, is energized by current from the line circuit.

With a direct current on the line, a direct current generator may be used; but with an alternating current an induction motor is required. The speed of the motor is governed by a rheostat, and the output of the dynamo is thus regulated as desired.

Ques. How may a battery be charged through the night without an attendant being present?

Ans. The charging may take place without any attention, if careful estimate of the amount of current required be made, and the rate of charge based on this estimate.

If, say, 72 ampere hours be required to recharge, and the time available is nine hours, the average rate of charge must be 8 amperes.

Assuming a 110 volt circuit, the rate at the start should be about 10 amperes; if from a 500 volt circuit, about 9 amperes; as, in charging from a source with constant voltage, such as a lighting or trolley circuit, the rate into the battery will fall as the charge progresses. This also applies if the charging be done, without attendance, from a mercury arc rectifier.

Ques. What precautions should be taken in charging a battery out of a vehicle?

Ans. When a battery is being overhauled, or out for cleaning, if charged before replacement in the vehicle, the cells must be connected together in series and to the charging source in relatively the same manner as if they were in the vehicle; that is, the positive (+) terminal of one group of cells must be connected to the negative (—) terminal of the next group, and the two free terminals, one positive and the other negative, must be connected respectively to the positive and negative terminals of the charging circuit, but not until all of the groups have been connected in series. **Great care must always be taken to have the polarities correct** and the wire or cable for the connections of ample size to carry, without heating, the heaviest current used in charging

The size used in the vehicle will be proper. The operation of charging is then carried on in the same manner as if the battery were in the vehicle.

Answers Relating to Battery Troubles, Care and Maintenance

Ques. How is short circuiting within a battery caused?

Ans. It may be caused by some of the active material (if the cell be of the pasted variety) scaling off and dropping between the plates, or by an over collection of sediment in the bottom of the cell.

Ques. How is short circuiting detected?

Ans. A short circuited cell is indicated by the marked difference in color of the plates or of the specific gravity of the electrolyte, as compared with the other cells.

If a foreign substance has become lodged between the plates, it may be removed by a wood or glass instrument.

If some of the active material has scaled off it may be forced down to the bottom of the jar. If excessive sediment be found, the jar and plates should be washed carefully, and re-assembled.

A cell that has been short circuited may be disconnected from the battery and charged and discharged several times separately, which may remedy the trouble.

No particular damage will be caused if the trouble be discovered and removed before these symptoms become too marked.

Ques. How should batteries be treated, when used but occasionally?

Ans. If a battery is not to be used for several days, it should first be fully charged before standing; if it continue idle, a freshening charge should be given every two weeks, continuing the charge when the cells begin to gas freely.

Ques. What action takes place when a battery stands idle for some time?

Ans. It loses part of its charge, due to local losses in the cells.

Ques. What should be done in case of lack of capacity?

Ans. If the current consumption, as shown by the meter, be greater than normal, the vehicle is running "hard," and

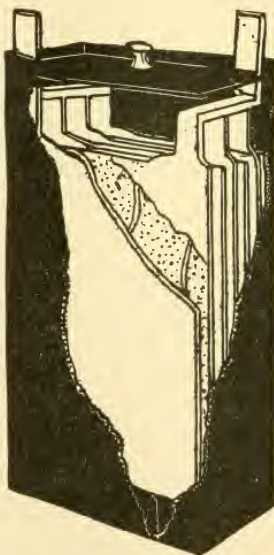

Fig. 308.—One cell of the Gould storage battery for electric vehicle use. According to the data given by the manufacturers, this cell, containing four negative and three positive plates, has a normal charging rate of 27 amperes; a distance rate of 22 amperes for four hours; a capacity of 81 ampere-hours at 3 hours discharge, and of 90 ampere-hours at 4 hours discharge. Forty such cells are generally used for an average light vehicle battery.

it should be overhauled. If, however, the current consumption be normal, there may be poor connections or trouble in the battery; there may be a dry cell, due to a leaking jar; some or all of the cells may be in a state of incomplete charge, due to the battery having been run too

low and not sufficiently charged, or the plates may be short circuited, either by the sediment (deposit in the bottom of the jar) getting up to the bottom of the plates or by something that has fallen into the cell.

Ques. How are internal short circuits indicated?

Ans. Short circuits in a cell are indicated by short capacity, low voltage and low specific gravity, excessive heating and evaporation of the electrolyte.

Ques. How are internal short circuits located?

Ans. If the trouble cannot be located by the eye, the battery should be connected in series and discharged at the normal rate through suitable resistance. If a suitable rheostat be not available, a water resistance may be used.

This consists of a receptacle (which must not be of metal) filled with very weak acid solution, or with salt water in which are suspended two metal plates, which are connected by wires through an ammeter. The current may be regulated by altering the distance between the plates, or by varying the strength of the solution. As the discharge progresses, the voltage will gradually decrease, and it should be frequently read at the battery terminals; as soon as it shows a sudden drop, the voltage of each cell should be read with a low reading voltmeter.

While the readings are being taken, the discharge rate should be kept constant and the discharge continued until the majority of the cells read 1.70 volts; those reading less should be noted. The discharge should be followed by a charge until the cells which read 1.70 volts are up, then the low cells should be cut out, examined, and the trouble remedied.

Ques. What causes low specific gravity when there are no short circuits?

Ans. 1, sloppage or a leaky jar (the loss having been replaced with water alone), 2, insufficient charge, 3, over discharge, or 4, a combination of these abuses. Any of these mean that there is acid in combination with the plates, which should be brought out into the electrolyte by a long charge at a quarter of the normal discharge rate.

Ques. How should the low cells be treated?

Ans. They should be grouped by themselves and charged as a separate battery, care being taken that the positive strap of one cell, is connected to the negative strap of the adjoining cell and that the charging connections are properly made. If there be not sufficient resistance in the charging rheostat to reduce the current to the proper point, a water resistance should be used.

While a cell is being treated, when possible, the cover should be removed (if sealed, the compound can be loosened by using a hot putty knife).

Ques. How should cells be disconnected?

Ans. The best method of disconnecting cells assembled with pillar straps, for the purpose of replacing broken jars, cleaning or taking out of commission, is to use a five-eighth inch twist drill, in a carpenter's brace, boring down into the top of the pillar about one-quarter inch; the connector sleeve is then pulled from the pillar. By following this method, all parts may be used again.

When cells are equipped with top straps, the straps should be cut with a sharp knife or chisel midway between the cells.

Ques. When should a battery be taken out of commission?

Ans. When it is to be out of service for several months, and it is not convenient to give it the freshening charge every two weeks.

Ques. Describe the method of taking a battery out of commission.

Ans. The battery is charged in the usual manner, until the specific gravity of the electrolyte of every cell has stopped rising over a period of one hour (if there be any low cells, due to short circuits or other cause, they should be put in condition before the charge is started, so that they will receive the full benefit of it). The cells may now be

disconnected and covers and elements removed from the jars, (if sealed, the compound is loosened with a hot putty knife). The elements are placed on their sides with the plates slightly spread apart at the bottom, the separators withdrawn, and the positive and negative groups pulled apart. The

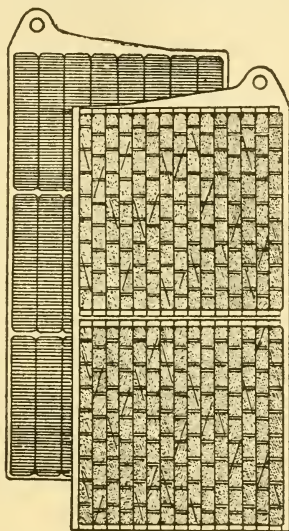

Fig. 309.—Plates of Edison storage battery. The positive or nickel plate consists of one or more perforated steel tubes, heavily nickel plated, filled with alternate layers of nickel hydroxide and pure metallic nickel in excessively thin flakes. The tube is drawn from a perforated ribbon of steel, nickel plated, and has a spiral lapped seam. This tube after being filled with active material is reinforced with eight steel bands, equidistant apart, which prevent the tube expanding away from and breaking contact with its contents. The tubes are flanged at both ends and held in perfect contact with a steel supporting frame or grid made of cold rolled steel, nickel plated. The negative or iron plate consists of a grid of cold rolled steel, nickel plated, holding a number of rectangular pockets filled with powdered iron oxide. These pockets are made up of very finely perforated steel, nickel plated. After the pockets are filled they are inserted in the grid and subjected to great pressure between dies which corrugate the surface of pockets and force them into practically integral contact with the grid.

electrolyte is washed off with a gentle stream of water and the plates allowed to drain and dry. The positive plates are ready to be put away. When dry, the negatives are completely

immersed in electrolyte (of about 1.275 specific gravity), and allowed to soak for three or four hours. The jars may be used for this purpose. After rinsing and drying, they are ready to be put away; wash also the rubber separators.

Wood separators, after having been in service, will not stand much handling and had better be thrown away. If it be thought worth while to keep them, they must be immersed in water or weak electrolyte, and in reassembling, the electrolyte must be

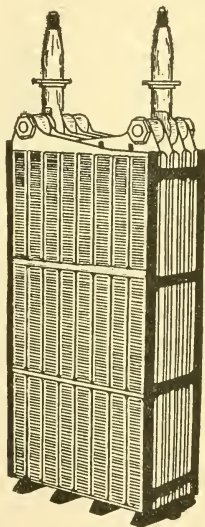

Fig. 310.—Complete element with insulators of Edison storage battery. After the plates are assembled into a complete element, narrow strips of treated hard rubber are inserted between the plates, thereby separating and insulating them from each other. The side insulator is provided with grooves that take the edges of the plates, thereby performing the dual function of separating the plates and insulating the complete element from the steel container. At the ends of the element, that is between the outside negative plates and container, are inserted smooth sheets of hard rubber. At the bottom, the element rests upon a hard rubber rack or bridge, insulating the plates from the bottom of container.

put into the cells immediately, as wet wood separators must not stand exposed to the air.

Ques. What precaution should be taken with the jars?

Ans. They should be thoroughly cleaned with fresh water, no sediment being allowed to remain.

Ques. How should a battery be put in commission?

Ans. It should be treated in the same manner as if it were new, and the regular instructions for assembling and putting into commission a new battery followed.

1. A battery must always be charged with "direct" current and in the right direction.

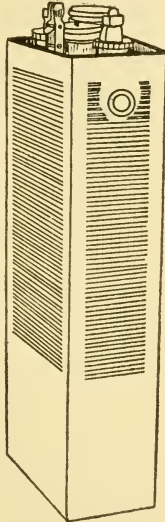

Fig. 311.—Cell of Edison storage battery. The jar or container is of nickel plated sheet steel with welded seams; the walls are corrugated to give strength. The cell cover of sheet steel has four mountings, two being pockets to contain stuffing boxes about the terminal posts. One of the other two is a separator which separates spray from the escaping gas while the battery is charging. The fourth mounting is for filling with electrolyte. The electrolyte consists of a 21% solution of potash in distilled water with a small per cent of lithia. The density of the electrolyte does not change on charge or discharge.

2. Care should be taken to charge at the proper rates and to give the right amount of charge, the battery should not be undercharged or overcharged to an excessive degree.

3. A naked flame should not be brought near the battery while charging or immediately afterwards.

4. The battery should not be allowed to overdischarge, or to stand completely discharged.

5. Voltage readings should be taken only when the battery is charging or discharging; if taken when the battery is standing idle they are of little or no value.

6. The battery temperature should not exceed 110° Fahr.

7. The electrolyte should be kept at the proper height above the top of the plates and at the proper specific gravity. Only pure water should be used to replace evaporation. In preparing the electrolyte, **water should never be poured into the acid.**

8. The cells should be kept free from dirt and all foreign substances both solid and liquid.

9. The battery and all connections should be kept clean and all bolted connections tight.

10. If there be lack of capacity in a battery, due to low cells, there should be no delay in locating and bringing them back to condition.

11. Sediment should not be allowed to get to the plates.

Ques. What is a mercury arc rectifier?

Ans. A device for converting alternating current into direct current for use in charging storage batteries.

Ques. Describe the construction and operation of a mercury arc rectifier.

Ans. Fig. 312 is an elementary diagram of connections. The rectifier tube is an exhausted glass vessel in which are two graphite anodes A, A', and one mercury cathode B. The small starting electrode C is connected to one side of the alternating circuit, through resistance; and by rocking the tube a slight arc is formed, which starts the operation of the rectifier tube. At the instant the terminal H of the

NOTE.—The Edison storage battery is manufactured in five sizes; all are identical in electrical characteristics, and differ only in the number and size of plates and capacity, as follows:

Type	B-2	B-4	A-4	A-6	A-8
Normal Ampere-Hour Output....	40	80	150	225	300
Average discharge voltage, per cell	1.2	1.2	1.2	1.2	1.2
Rate of charge, in amperes, for seven hours.....	$7\frac{1}{2}$	15	30	45	60
Normal rate of discharge, amperes	$7\frac{1}{2}$	15	30	45	60
Weight, in pounds, of cell complete.....	$4\frac{1}{2}$	7	$13\frac{1}{2}$	$19\frac{1}{2}$	$25\frac{1}{2}$
Average weight in lbs., per cell, assembled in tray.....	$4\frac{1}{2}$	$7\frac{1}{2}$	$14\frac{1}{2}$	20	26
Tray dimensions— <i>inches, length—2 cell</i>	$6\frac{3}{8}$	$7\frac{1}{2}$	10	$12\frac{1}{8}$
Required height of battery compartment.....	$8\frac{3}{8}$ "	$8\frac{1}{2}$ "	15"	15"	15"
All trays are $6\frac{1}{8}$ inches wide.					

supply transformer is positive, the anode A is then positive, and the arc is free to flow between A and B. Following the direction of the arrow still further, the current passes through the battery J, through one-half of the main reactance coil E, and back to the negative terminal G of the transformer. When the impressed E. M. F. falls below a value sufficient to maintain the arc against the counter E. M. F. of the arc and load, the reactance E, which hereto-

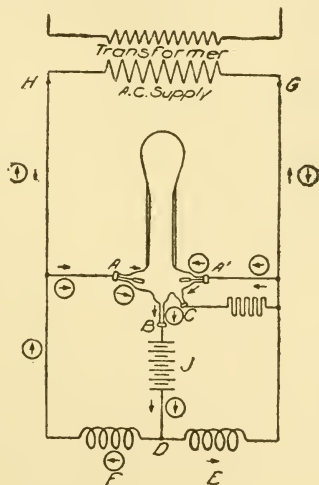

Fig. 312.—Elementary diagram of mercury arc rectifier connections. A, A', graphite anodes; B, mercury cathode; C, small starting electrode; D, battery connection; E and F, reactance coils; G and H, transformer terminals; J, battery.

fore has been charging, now discharges, the discharge current being in the same direction as formerly. This serves to maintain the arc in the rectifier tube until the E. M. F. of the supply has passed through zero, reversed, and built up such a value as to cause the anode A to have a sufficiently positive value to start the arc between it and the cathode B. The discharge circuit of the reactance coil E is

now through the arc A'B instead of through its former circuit. Consequently the arc A'B is now supplied with current, partly from the transformer, and partly from the reactance coil E. The new circuit from the transformer is indicated by the arrows enclosed in circles.

Ques. How is a mercury arc rectifier started?

Ans. A rectifier outfit with its starting devices, etc., is shown in fig. 313. To start the rectifier, close in order named line switch and circuit breaker; hold the starting

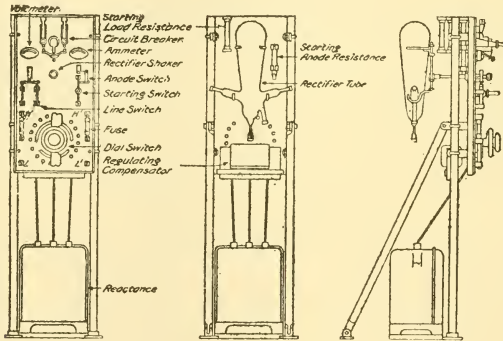

Fig. 313.—Mercury arc rectifier outfit, or charging set. The cut shows front, rear, and side views of the rectifier, illustrating the arrangement on a panel, of the rectifier tube with its connection and operating devices.

switch in opposite position from normal; rock the tube gently by rectifier shaker. When the tube starts, as shown by greenish blue light, release starting switch and see that it goes back to normal position. Adjust the charging current by means of fine regulation switch on the left; or, if not sufficient, by one button of coarse regulation switch on the right. The regulating switch may have to be adjusted occasionally during charge, if it be desired to maintain charging amperes approximately constant.

METHODS OF CIRCUIT CHANGING

The methods employed to vary the speed and power output of an electric vehicle motor consist briefly in such variation of the electric circuits as will modify the pressure of the batteries on the one hand, and the operative efficiency of the motors on the other.

With respect to the circuit arrangements, one general principle may be laid down, which is, that a connection of a number of cells in **series** involves an increase in the pressure of the battery which is equal to the sum of the individual voltages. Connecting a number of cells in **parallel** or **multiple** has the effect of producing a pressure only equal to the voltage of one of the units.

Thus, if four cells of 10 volts each be connected in series, the pressure is equal to 40 volts. If, however, they be connected in parallel or multiple, the pressure is equivalent to but 10 volts, but four times the amount of current is available as in the former case.

Answers Relating to Methods of Circuit Changing

Ques. What is the general arrangement of the battery, motor, and accessories?

Ans. The cells comprising the storage battery are so arranged as to form a number of units, being so wired that by the use of a form of switch known as a controller the

connections may be varied from series to multiple, or the reverse, as desired. The same arrangement for varying the circuit connections is used for the field windings.

The wiring diagrams, figs. 314 to 316, show one arrangement. The dotted lines on each figure indicate the circuits that are cut

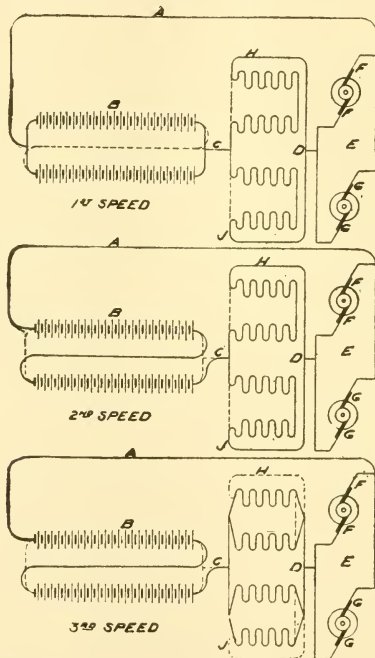

Figs. 314 to 316.—Diagrams of the circuit changing arrangements of a typical electrical vehicle. The full lines in these diagrams indicate the closed or active circuits; the dotted lines the open, or inactive circuits. As may be readily understood, the whole scheme of the circuit changing depends on employing several different circuit connections between battery and motor, which may be opened and closed, as desired. Here A and C are the lead wires between battery, B, and motor brushes, FF and GG, and the field windings H and J, and the wire, D.

out, or open, and the full lines, those that are active or closed. The upper figure shows first speed; two units of the battery B are connected in multiple, which means that the voltage is reduced to the lowest point. The wire, C, connected to the bridge between the positive poles of the battery, leads the current to the field

windings, H and J, which, in this figure, are connected in series-multiple, which gives the lowest speed and power efficiency of the motors. By the wire, D, the current is carried to the brushes, FF and GG, which, according to this scheme, are permanently connected in multiple, the return path to the negative pole of the battery being through the wire A.

In the middle figure, the circuit is varied so as to connect the two units of the batteries, so as to give its highest pressure efficiency. But, since the field windings of the motors are also connected in series, or in series-parallel, as in this case, the efficiency in speed and power is reduced nearly one-half.

In the lower figure, the two units of the battery are connected in series, which, as in the former case, indicates the greatest efficiency in power output; but the field windings are connected in parallel, which means that the voltage generated by their operation is equivalent to the voltage of only one motor, with the result that the speed and power efficiency is raised to its highest point.

Ques. Describe the method of circuit changing illustrated in the diagram, fig. 317.

Ans. For first speed the controller is rotated so that the row of terminal points, A, B, C, D, E, F, G, are brought into electrical contact with the row of terminal points, on the controller, A', B', C', D', E', F', G'; this connects the two unit battery in multiple, and the field windings of the two motors in series. A further movement of the controller, bringing the points, A, B, C, etc., into contact with A², B², C², etc., gives second speed, the batteries now being in multiple, and the fields in series-multiple. For third speed, the points B and C are brought into contact with B³ and C³, and E and F with E³ and F³, which means that the batteries are connected in series, and the fields in series. Similarly, for fourth speed, the points B and C are brought into contact with B⁴ and C⁴, and D, E, F, G, with D⁴, E⁴, F⁴, G⁴, which means that the batteries are in series and the fields in multiple.

The connections between the battery, the armature brushes, and the motor fields, are made as indicated through the rotary reversing switch by the terminals, K, L, M, N. This switch may effect the reversal of the motors by giving a quarter turn to its spindle, which means that the contacts of segment X, will be

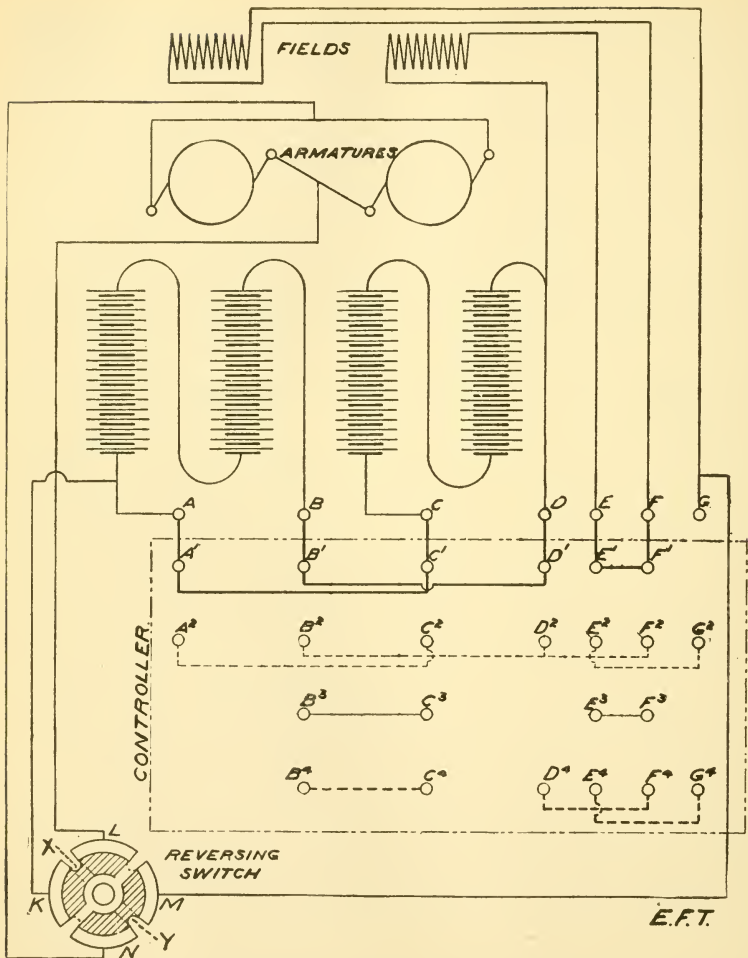

Fig. 317.—Diagram plan of the several parts of an electric vehicle driving circuit. The field windings and armatures are shown projected, the proper wiring connections being indicated. The periphery of the controller is laid out within the broken line rectangle, the contacts and connections through it for varying the circuits through four speeds being shown.

shifted from L and K to K and N, and the contacts of segment Y, shifted from M and N to L and M, thus reversing the direction of the current.

Some manufacturers vary the scheme in the last two figures by connecting the armature brushes and fields of each motor into series and shifting the circuit connections, where two motors are used, from series to series-parallel. In figures 318 to 320 showing the combination of one battery unit with two motors, the connections for the three speeds obtained are obvious. Since only one unit is used, the lowest pressure of the battery can be obtained only by inserting a resistance coil, R, in the circuit, with the armature brushes, field windings and both motors connected in series. For the second speed, the resistance is simply cut out, allowing the full current of the battery to pass through the armatures and windings of both motors, still connected in series. For the third speed, the connections of armatures and motors are shifted to multiple, or series multiple.

Ques. How may the circuits be arranged with two batteries and two motors?

Ans. For this combination, as shown in figs. 321 to 323, it is possible to eliminate the resistance coil altogether and depend entirely upon the circuit shifting for regulating the voltage and power. Accordingly, for the first speed the batteries are connected in multiple, and the armatures and windings of the two motors in series. For the second speed, the series connections are adopted for both batteries and motors, while for the third speed the batteries are in series, with the motors in parallel.

Ques. Describe the method of circuit changing illustrated for a four battery one motor combination, as shown in figs. 324 to 326.

Ans. With this arrangement, the several speeds are obtained by simply changing the battery circuits without alteration of the armature or field connections. For the first speed the four units are connected in parallel, which gives a total voltage equivalent to the voltage of any one of them. For the second speed, the battery units are connected in series, the two pairs thus formed being joined in multiple, with the result that the total voltage of the battery

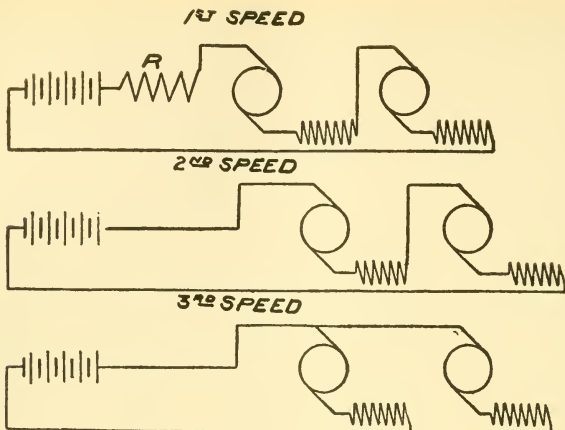

Figs. 318 to 320.—Diagrams showing methods of speed changing in a typical one battery unit, two motor circuit. The first speed shows the two motors *in series*, with a resistance coil interposed; the second, the motors *in series*, without the resistance; the third, the motors *in multiple*.

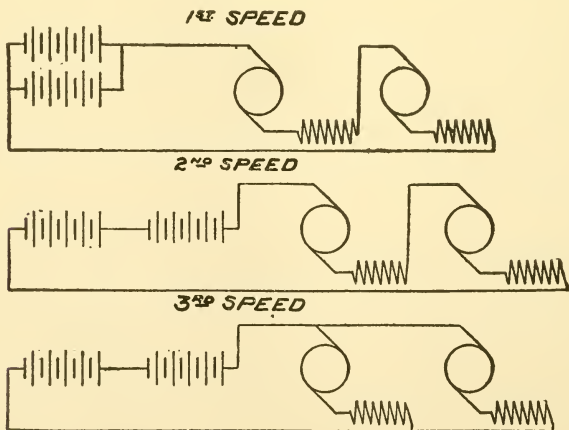

Figs. 321 to 323.—Diagram showing methods of speed changing in a two battery unit, two motor circuit, showing combinations for three speeds. The first speed is obtained with the battery units *in multiple*, and the motors *in series*; the second, with the battery units *in series* and the motors *in series*; the third, with the battery units *in series* and the motors *in multiple*.

is equivalent to the sum of the pressures of two of the units, or twice the voltage used in the first speed. For the third speed, all four units of the battery are connected in series, thus doubling the voltage again, and realizing the highest speed and power efficiency possible in the combination.

Ques. Explain the construction of the controller of an electric vehicle.

Ans. This consists of a rotatable insulated cylinder, as shown in fig. 327, carrying on its circumference a number of

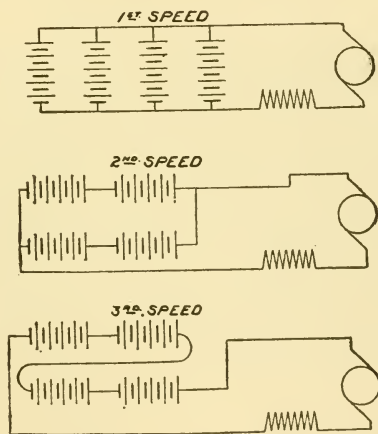

Figs. 324 to 326.—Diagrams showing combinations for three speeds in a typical four battery unit, single motor circuit. The only changes made in these circuits are in the battery connections. For the first speed the battery units are *in multiple*; for the second, *in series multiple*, for the third, *in series*. The motor connections are not varied.

contacts, arranged to make the desired connections with the terminals of the various devices in the circuit through a wide range of variation. The connections of the terminals of the batteries, of the field windings, and other elements of the circuit, are made at the binding posts at the front base of the instrument. From each of these binding posts, which are electrically insulated from one another, jack

springs rise to a position convenient to make connections with the switch blades arranged along the periphery of the controller cylinder. These switch blades, as may be seen, are secured to the controller cylinder by screw connections, being arranged singly, or several of them together on one plate.

In the case of a pair of blades, shown in contact with the spring at either extremity of the controller cylinder, it is evident that there is an electrical contact, through the base plates, between the two terminals, represented by the contact springs in engagement. Between these two end plates, as may be seen, there are several switch blades arranged singly upon the circum-

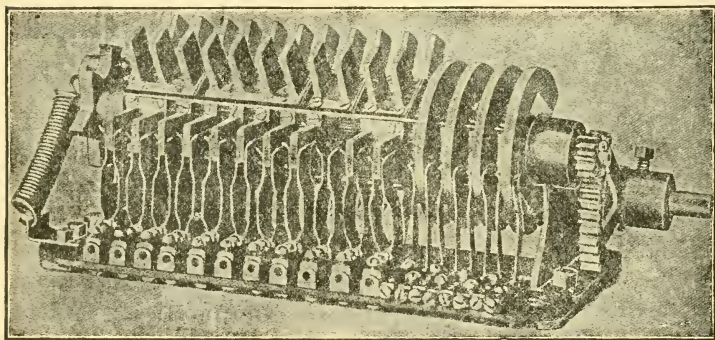

Fig. 327.—A typical electrical vehicle controller, or circuit changing switch. The circuit terminals of the battery and motors are shown at the jack springs, which are arranged to be engaged by the fins on the periphery of the controller cylinder. The connections within the controller, between the fins, are the same as those shown in fig. 330, except for the fact that the four rings at the right hand end provide constant voltage connections for use with a shunt motor. The gaps at the rear of the rings show means for cutting out the shunt field at top speed.

ference. At one point there is no contact whatever, showing that the terminals represented by the contact springs at that point are out of circuit. The several blades that are arranged singly on the controller surface have such electrical connections as the scheme of circuit variation adopted demands; these are made through insulated wire connections arranged between any pair it is desired to connect.

Ques. Describe a second type of controller.

Ans. A simple construction is shown in fig. 328, the controller here illustrated consists of a cylindrical surface,

upon which bear single leaf springs, the desired electrical connections being made by conducting surfaces suitably connected on the cylinder circumference, and cut-outs being similarly accomplished by insulating surfaces, bearing against the spring contacts at the desired points.

This type of controller is one of the most usual forms for motor vehicle purposes. As is obvious, it is possible to so arrange the electrical connections on the controller surfaces that by proper contacts with the terminal springs, reversal of the motor may be

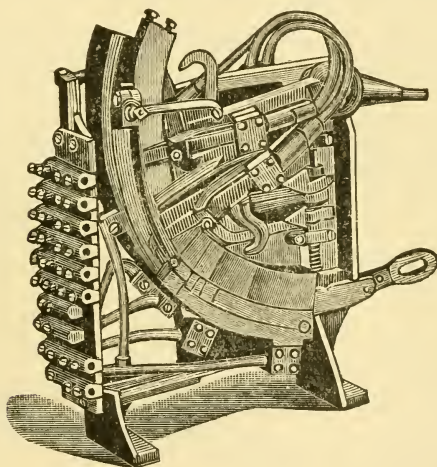

Fig. 328.—Controller of the Rauch and Lang electric vehicles. It is of the flat radial type. Two movable copper leaf contacts of ample size make all commutations necessary to obtain the various speeds. Five speeds forward and reverse are provided.

accomplished, as shown on the last circuit diagram. This is done in a number of controllers, the reverse being accomplished at a definite notch on the quadrant of the shifting lever.

Ques. What attention should be given to the controller contacts?

Ans. The cable connections to the controller should always be kept tight, and it is essential that the controller fingers make firm connection with the contacts correspond-

ing to the different speeds, as otherwise there may be arcing, which will roughen their surfaces and cause the lever to work hard.

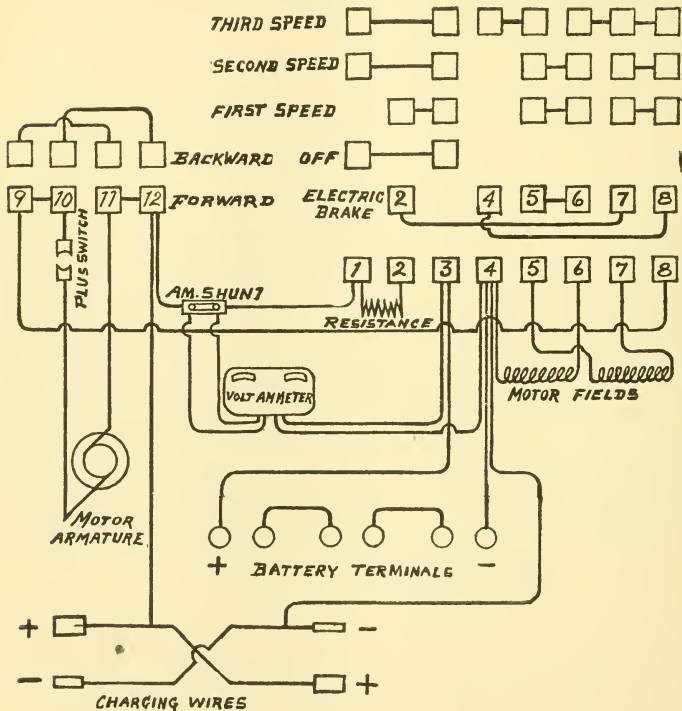

Fig. 329.—Diagram of controller connections of a one unit, one motor circuit, with variable fields.

Ques. What should be done if the contacts become burnt?

Ans. They should be smoothed with a file, when the current is cut off by the safety plug, and a minute amount of vaseline rubbed over them to lessen friction. All copper particles or other dust should be blown or wiped off the

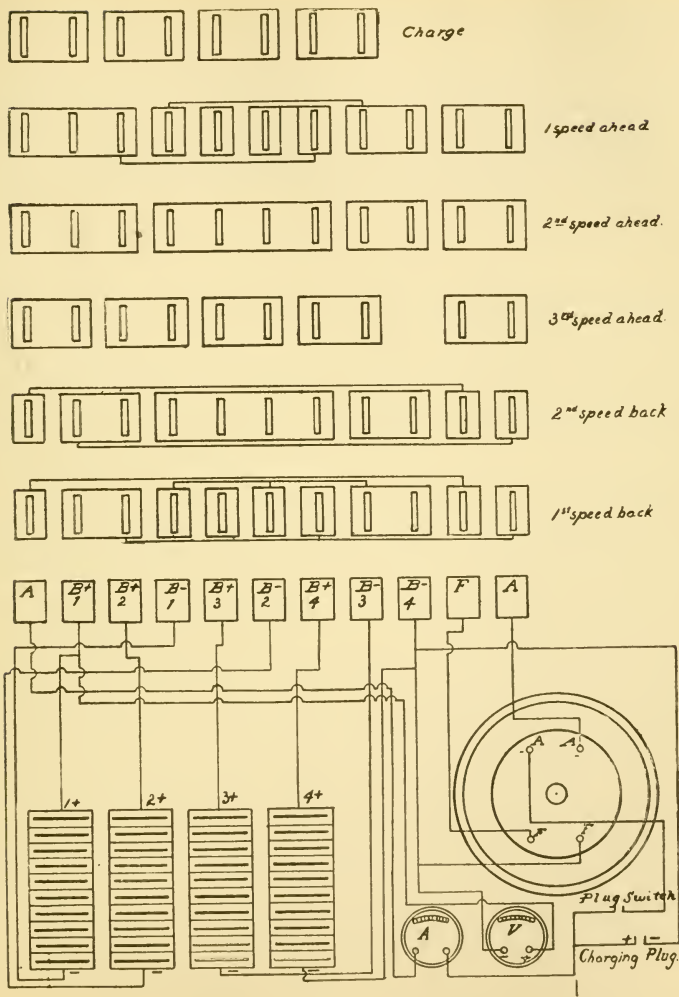

Fig. 330.—Diagram of controller connections of a four unit one motor circuit, with constant series connections for fields and armatures in forward and backward speeds.

controller and its connections, as a short circuit might result therefrom.

The acid fumes produced by the battery, and the slopping of the electrolyte which sometimes takes place, are likely to cause a destructive corrosion of all metal parts subjected to their influence. Whenever it can be used, asphaltum or tar paint will be found a good preservative and parts which cannot be so treated should be frequently wiped off.

HOW TO RUN AN AUTOMOBILE

Since safety and comfort in automobiling depend largely upon the skill of the driver, it should be the aim of every one, who undertakes to operate a car, to acquire a knowledge of the correct methods of driving. The best way to learn is a question that must be decided, in a measure, by individual circumstances.

In the handling of a car on the road by the average driver, it would be difficult to find two who adopt the same methods. This is due to the varied experience the drivers have had, and to their degree of knowledge of the theory and principles of the automobile. Under suitable conditions, the gas engine will run for a long time without attention. However, a slight fault will often cause considerable trouble, the symptoms of which may not be plain enough to enable the trouble to be located directly, and the whole system must be gone over sometimes before it is located. It is, therefore, necessary to know just what is happening under the bonnet, and just when some things should happen, that reasonable satisfaction may be derived from the car.

There is no car that can be expected to be free from trouble, for even the best workmanship and material may give way sometimes.

An inexperienced driver will find that he cannot get as much out of a car as the demonstrator for some little time, or till he is thoroughly accustomed to the car and knows how to handle it, whether travelling uphill or on the level.

A driver should: 1, be well acquainted with the carburetter and ignition system, 2, understand the management of the spark, throttle, and control levers under varying road conditions, 3, give proper attention to lubrication, and 4, be able to make repairs resulting from the ordinary mishaps likely to be encountered on the road.

In the chapter on engine operation, detailed instructions are given for its management and care, hence, it will suffice to say little here on this subject.

Before taking a car on the road, the driver should first make himself familiar with the instructions given in the above mentioned chapter and also with the "control" system, which will now be explained.

Answers Relating to the Control System

Ques. Explain the term "control."

Ans. This relates to the various levers and devices used in running the car, and which are conveniently located on the dash, steering column and foot board.

A typical arrangement of control levers is shown in fig. 331: they are marked in the figure and their location should be carefully noted.

Ques. Explain the use of the throttle levers.

Ans. It will be seen from fig. 331 that there are two throttle levers, one for hand, and one for foot operation. This is the usual arrangement. In running a car through crowded streets where frequent speed changes are to be made, this is done most conveniently with the foot. A downward pressure of the foot opens the throttle; it closes automatically when released by the action of a spring. The foot throttle is also used when shifting the transmission gears, as one hand is required to operate the gear shifting lever, while the other is engaged in steering the car.

Ques. How should the throttle be operated on an open or country road?

Ans. Here the running conditions are such that the hand throttle lever may be used to advantage, since it need

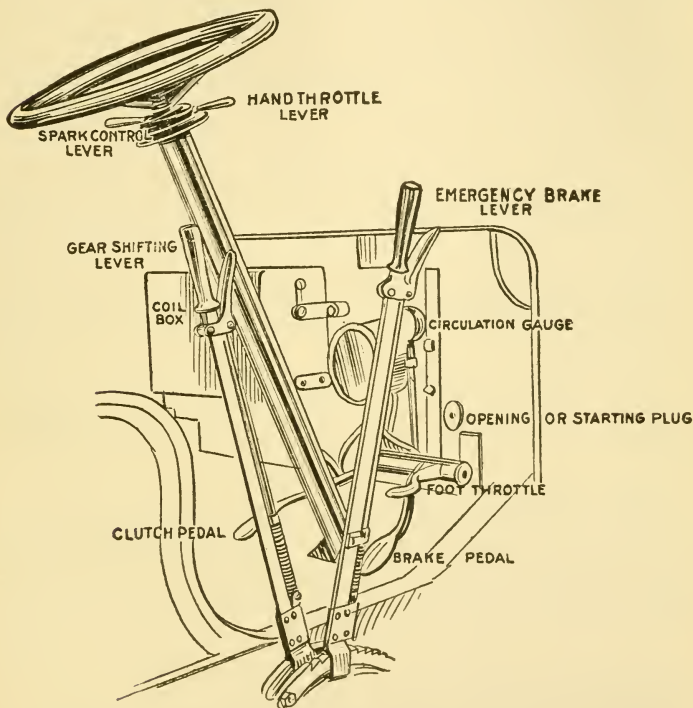

Fig. 331.—Control levers and dashboard appliances on a gasoline automobile. Located at the side of the car are the two levers which operate the brake and shift the change speed gears. As shown, the throttle and spark levers are just below the steering wheel; a number of cars have the levers placed on top of the wheel. The arrangement of foot pedals illustrated in the figure is to be found on nearly all makes of cars.

not be moved so often. The hand throttle may be set at any desired opening and it will remain in any position, whereas if the foot throttle be used, it is necessary to retain it in position by the foot against the tension of the

spring. The latter operation naturally becomes tiresome if continued for any length of time, hence, the hand throttle furnishes a ready relief.

Ques. Can the throttle be entirely closed by the levers?

Ans. No; the connections are so adjusted that when the lever is in the closed position, the supply of fuel mixture to the engine is not entirely shut off, but just sufficient to keep the engine in motion.

As shown in the illustration, the throttle lever is placed below the steering wheel, however, on most cars it is placed above the wheel. A notched segment is provided to retain the throttle in any setting.

Ques. Where is the spark lever located?

Ans. It is superposed on the steering wheel with the throttle lever.

Ques. What two brakes are usually provided?

Ans. The running or **service** brake, and the **emergency** brake.

Ques. How are they operated?

Ans. The running or service brake is operated by the foot pedal and is released by a spring when not held down. The emergency brake is operated by a hand lever at the side of the car near the transmission lever.

Ques. What connection is there between the clutch and the service brake, and why?

Ans. The construction is such that when this pedal is depressed to apply the brake, the clutch is simultaneously released. This arrangement prevents an inexperienced or confused driver applying the brake without releasing the clutch—a proceeding which would strain or bring heavy stresses on the engine and driving gear.

Sometimes the emergency brake is arranged to simultaneously release the clutch when applied, but this construction has

been criticized by some authorities as undesirable in handling a car on a hill.

It is pointed out, that if necessary to stop the car in ascending a hill, the brakes must be released before the clutch can be thrown in, with the possibility of the car starting down hill backward before the power can be applied. The chance of stalling the engine through this and the danger of the combination to any but an experienced driver, it is contended, make it advisable to have the emergency brake separate from any connection with the clutch.

Ques. How is the emergency brake lever retained in position?

Ans. It is provided with a pawl and notched segment; the latter is concentric with the segment of the transmission gear shifting lever, the brake lever being always placed outside. On some cars the segment has a hole drilled to receive a padlock. When the lever is drawn past this hole and the padlock inserted, the clutch is out and the brake applied, so that the car is protected against unauthorized use, or theft.

Ques. Where is the clutch pedal located?

Ans. On the floor board, to the left.

Ques. Explain its operation.

Ans. By pressing down this pedal the clutch is released, which allows the engine to run free. There is a connection between the clutch and brake pedals, such that if the latter be pressed down the clutch is released at the same time the brake is applied.

Some cars have a simplified arrangement in which a single pedal operates both clutch and brake. Pressure on this pedal first throws out the clutch while continued movement of the pedal applies the brake. This arrangement leaves the right foot free to operate the foot throttle.

Ques. Where is the transmission gear shifting lever located, and how distinguished?

Ans. It is placed beside the emergency brake lever, but is always the inner one, or that one nearest the driver. On most cars it is further distinguished by the construction, as is shown in fig. 334, the brake lever being provided with

an external latch while the transmission lever has a press button on top, the latch link passing down through the handle.

Ques. What is the object of the latch on the gear shifting lever?

Ans. To retain the lever in position for a progressive transmission, or, in the case of a selective transmission, to prevent placing the lever in the reverse position.

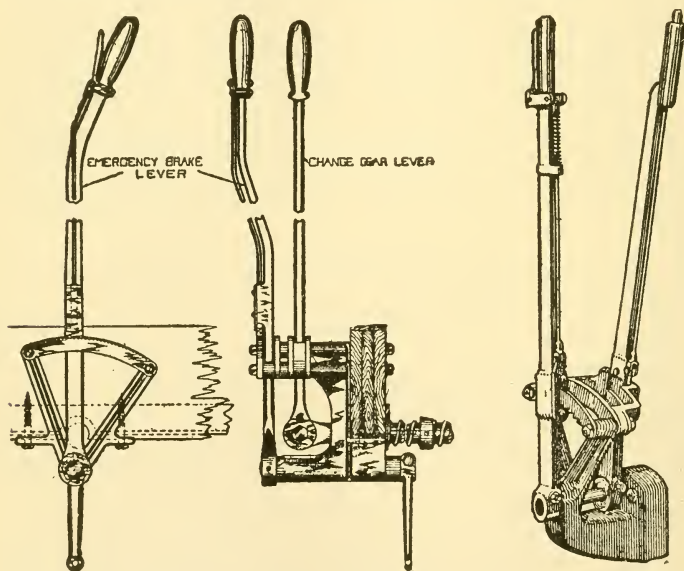

Figs. 332 and 333.—Franklin emergency brake and transmission levers, as applied to models having progressive transmissions

Fig. 334.—Characteristic side lever control. The two levers have distinctive constructions, the brake lever having an external latch mechanism and the transmission lever being provided with a press button at the top of the handle and connection running through same.

Ques. Describe the operation of a gear shifting lever with a progressive transmission.

Ans. With this type of change speed gearing, a simple linear movement of the lever is sufficient to affect the

different gear changes, the lever being rotated through the proper arc, as shown in fig. 335, the positions for the different speed changes are shown by the dotted lines, the latch segment having notches in the proper places to retain the lever in position.

Ques. How is the selective transmission lever operated?

Ans. It is necessary to give this type lever both a linear

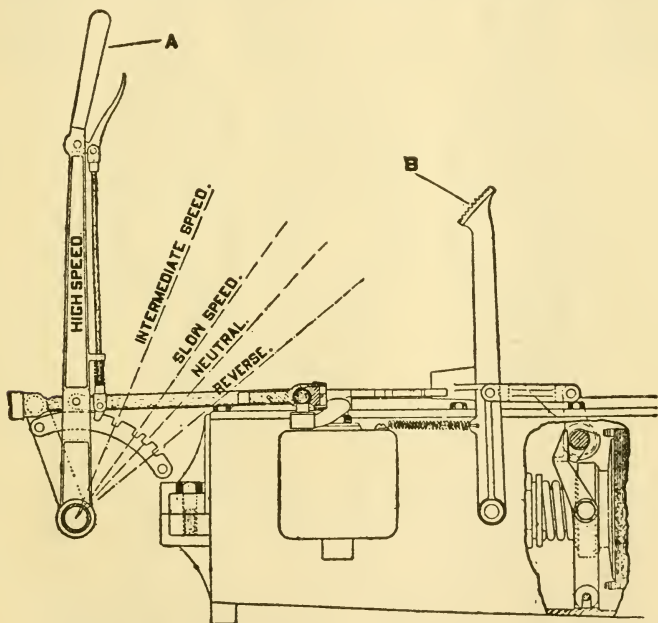

Fig. 335.—The Maxwell transmission lever, showing the several positions of the lever in making the speed changes. The transmission is of the progressive type.

and a lateral movement; a compound form of segment, known as a selector is required.

Ques. Describe a selector.

Ans. This is simply a compound segmental guide, having two slots for a three speed transmission, three slots

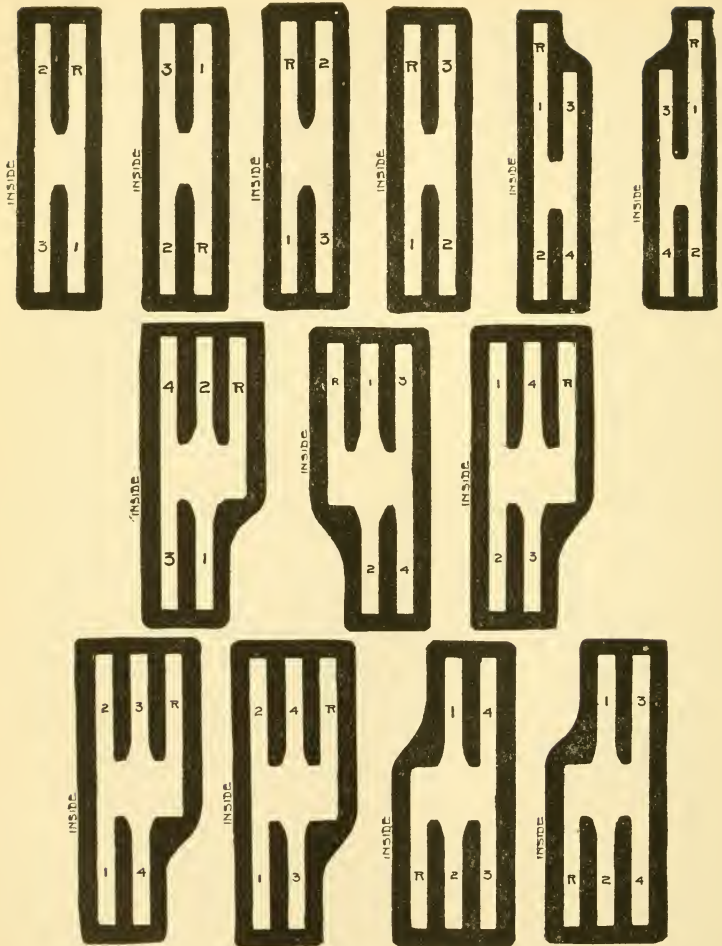

Fig. 336 to 341.—Types of three speed selectors as used on well known American automobiles in the greatest proportion. Fig. 336, Franklin; fig. 337, Columbia and Corbin; fig. 338, Apperson, Cadillac, Elmore, Knox, Oldsmobile, Walter, Winton and Thomas; fig. 339, Buick model five; fig. 340, Locomobile; fig. 341, Thomas.

Figs. 342 to 348.—Types of four speed selectors as used on American automobiles, showing wide variation: fig. 342, Lozier model G; fig. 343, Peerless and Stearns; fig. 344, Studebaker; fig. 345, Lozier model H; fig. 346, Matheson; fig. 347, Toledo; fig. 348, Simplex.

for four speed transmissions, and a central gate to provide for the necessary lateral movement of the lever in passing from one slot to another.

Fig. 334 shows the position of the selector with respect to the lever. The brake lever is also shown on the outside, the whole forming a structural unit which is attached to the side of the car. In shifting the gears for the several speed changes, the lever is moved to the various slot terminals, the central position at the gate corresponding to the neutral position.

Ques. What is the arrangement of the slot terminals for the different speeds?

Ans. There seems to be no standard arrangement; in fact, a great diversity exists, as is shown in figs. 336 to 348.

Figs. 336 to 341 are examples of three speed selectors, and figs. 342 to 348, four speed selectors, showing the varied slot arrangements to be found on different makes of cars. The numerals, 1, 2, 3 and 4 indicate the position of the lever for the different speeds forward, R being the position for reverse.

Ques. What is the action of the muffler?

Ans. It tends to increase the back pressure of the exhaust and thereby diminish the power of the engine.

Ques. How may this excess back pressure be avoided in running over heavy roads or ascending a hill?

Ans. A cut out valve is connected to the exhaust pipe between the engine and muffler. The operation of this valve is controlled by a press button placed on the foot board usually located conveniently to the driver's left foot.

Ques. What other signal besides a horn is sometimes provided?

Ans. A chime whistle is sometimes fitted to four or six cylinder cars, and operated by the exhaust from the engine; this produces a pleasing sound, especially on a six cylinder car, the rapid variations of the exhaust pressure producing a trembling tone. The whistle is connected to the exhaust pipe with a tee, and its valve operated by a push button located on the foot board near the muffler cut out button.

Ques. What device is usually provided to prevent anyone operating the car in the absence of the owner?

Ans. An ignition cut out plug is inserted in the primary circuit and located on the dash, or some other convenient yet non-conspicuous place, so that the plug is easily removed on leaving the car.

Ques. Describe a self starting device.

Ans. The method employed by the Winton Company on their six cylinder car is as follows: Attached to cylinders 1 and 6 are outlets through which a small portion of the pressure of each power stroke passes to a pressure tank placed between the left frame rail and the driving shaft. Here the pressure is stored until required to start the motor when a cock is opened, allowing the pressure to flow through the distributor to one of the cylinders. The pressure forces this piston down, and at the same time another piston passes the firing point and the motor starts. However, if for any reason the first cylinder should fail to fire, the distributor sends the pressure to the cylinder next in order, and forces the next piston past the firing point, and so on if necessary, through a series of cylinders.

Ques. How is this self-starter operated?

Ans. The control of the self-starter is shown in fig. 349; it consists of a push button, which allows pressure to flow from the tank to the cylinders. Immediately above the push button is the pressure gauge, which indicates the amount of pressure in the tank. In addition, there is a shut off valve for use when the car is to remain long idle, preventing loss of pressure from the storage tank.

The other devices shown in the dash assemblage are: 1, the auxiliary gasoline tank at the left, 2, the spark coil, and 3, the oil sight feed

Answers Relating to Starting

Ques. How is a car started?

Ans. After starting the engine as previously directed, the driver takes his seat and starts the car as follows: Before any load is put on the engine its speed is increased by

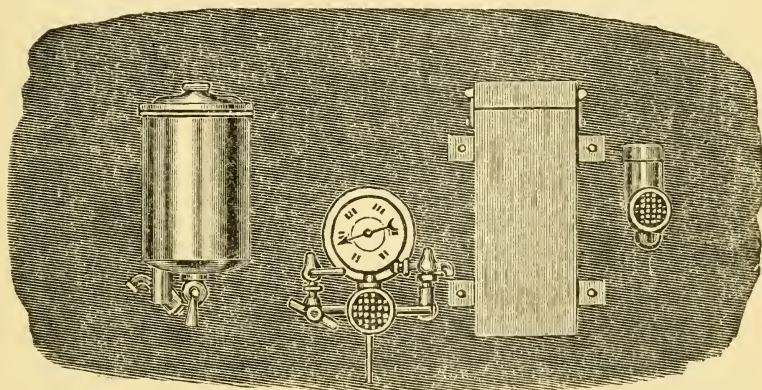

Fig. 349.—Winton six dash assemblage, showing from left to right the auxiliary gasoline tank, the shut off, push button and gauge of self-starter, the spark coil and oil sight feed.

slightly retarding the spark, in order to store up in the fly wheel sufficient momentum to keep it going between power strokes, against the added resistance of the load. This increased speed, as stated, is secured by spark adjustment rather than by changing the throttle position—the latter method being reserved for any additional increase of speed that may be necessary. The clutch pedal is next fully depressed and then the emergency brake released. With clutch still disengaged, the transmission lever is moved

from **neutral to first speed position**, also the right foot placed on the throttle pedal, or **accelerator** as it is sometimes called, ready to press down and increase the throttle opening should the engine show any tendency to diminish its speed or stop. The clutch pedal may now be slowly **raised**, which will allow the clutch to engage gradually and start the car easily and without jerk.

The transmission lever, in the above, was assumed to be originally in neutral position, to which position it should always be brought when the car is stopped. It should be remembered that the emergency brake and clutch are so connected that when the brake is set, the clutch is automatically released, it being thrown into engagement with the transmission upon the release of the brake. Hence, to prevent the clutch being thrown in, when the brake is released, the clutch pedal is held down before releasing the brake.

Ques. How are the gears shifted to second speed?

Ans. In making a speed change there are three things to be done, and it is important to remember the order in which these operations should be performed, viz: 1, the clutch must be detached by pressing down on the clutch pedal with the left foot, and **after waiting one or two seconds, in order that the two gears to be meshed shall be revolving at nearly the same speed**, 2, the transmission lever is quickly moved to **second speed position**, and 3, the clutch gradually re-engaged or thrown in.

Ques. What attention must sometimes be given to the engine during the wait for synchronism of the revolving gears?

Ans. It is usually necessary to accelerate the speed of the engine by the foot throttle, especially when running over a heavy road.

Ques. Describe the change from second to high speed.

Ans. On most cars this is the speed of direct drive and in shifting the gears for this speed, the driver proceeds in the same manner just described for changing to second speed,

that is, **after releasing the clutch** the transmission lever is moved to the high speed position, and then the clutch is gradually re-engaged or thrown in again.

In the four speed transmission there is an additional speed to pass through, but the same operations as just described are performed.

In some four speed transmissions the direct drive is the fourth speed, while in others the construction is such that the direct drive is on the third speed, the fourth speed gearing the engine to run slower than the propeller shaft.

Ques. How is the speed of the car usually regulated?

Ans. In running the car, the speed is almost always regulated by the throttle, the accelerator, or foot pedal being used mostly. The hand throttle lever is used occasionally as a relief, to prevent fatigue of the ankle muscles, or where the car is run considerable distances without speed changes, as on open country roads.

Ques. What is the proper method of handling a car to make a gradual and a quick stop?

Ans. When making a gradual stop: 1, the throttle may be closed, allowing the compressional resistance of the engine to act as a brake, until the car has reduced its headway, 2, the left pedal is now depressed throwing out the clutch, and 3, the foot brake applied with the right pedal. To make a quick stop, both the clutch and brake pedals may be pressed simultaneously and the emergency brake set. In making a stop, the transmission lever should always be placed in the neutral position; the throttle should be closed, and spark advanced so that the engine will not race.

Ques. How should the car be reversed?

Ans. After the car has come to a standstill: 1, the clutch is held out with the left pedal, 2, brakes released, 3, the transmission lever moved to the **reverse position**, and 4, the clutch **gradually** thrown in.

Answers Relating to Spark Control

Ques. What qualifications are necessary for the proper management of the spark under varied running conditions?

Ans. The driver should have an understanding of ignition and carburetter principles, together with extensive experience in operating the car.

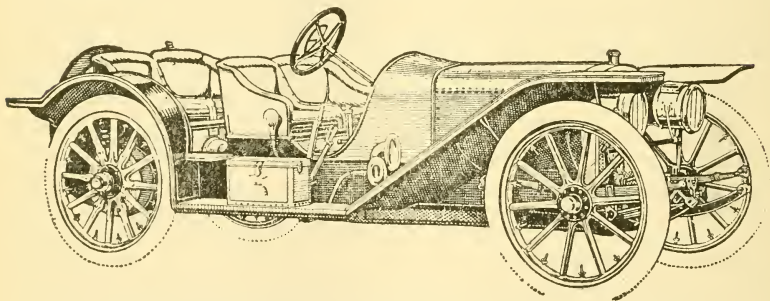

Fig. 350.—The American Traveller with 40 inch wheels. An example of the underslung frame type of car. Four cylinder engine, bore $5\frac{3}{8}$ in.; stroke, $5\frac{1}{2}$ in., 50 H. P. Double ignition system—Bosch high tension magneto and single unit coil.

Ques. On what does the spark control depend?

Ans. It depends somewhat on the kind of ignition used.

Ques. How is the spark influenced by a vibrating coil?

Ans. When a vibrating spark coil is used, no such advance of the spark is possible as would be indicated by the position of a timer apparently capable of a movement of 90 degrees or more. This is due to the lag in the vibrating spark coils. Hence, it should be remembered that with a vibrating coil, the spark position as indicated by the spark lever is always in advance of its true position—the difference increasing with the engine speed.

Ques. What effect has a high tension magneto on the spark?

Ans. There is no lag due to make and break of the primary circuit as with a vibrator coil, because the mechanically operated interrupter of a high tension magneto is positive in its action.

Ques. What other condition governs, to some extent, the control of the spark?

Ans. The quality of the fuel mixture.

Ques. How should the mixture vary for low and high speeds?

Ans. At low speeds it should be richer than at high speeds, on account of heat and compression losses.

In this connection it should be remembered that a lean and highly compressed charge burns faster than a rich one, and the spark position should be modified to suit the immediate conditions of combustion.

Ques. What is the effect of a late spark?

Ans. A late spark, especially with a rich mixture, causes the engine to heat and results in an increased consumption of gasoline. When on the road, the best results are usually obtained by advancing the spark lever as far as possible without the engine pounding.

Ques. How should the spark be controlled under running conditions?

Ans. Definite rules for handling the spark lever cannot be laid down, as conditions vary with the kinds of roads being travelled, difference in engines, ignition system, etc., but a good driver will not allow the engine to pound.

Ques. What should especially be avoided in spark control?

Ans. A very late spark. The general practice among drivers, when desiring to keep the engine running slowly, is to retard the spark and throttle the fuel mixture as much as possible, the adjustments being usually set to allow the engine to just keep running under these conditions. This

practice is responsible for the need of grinding in valves at short intervals.

With the spark lever retarded, the gas is ignited so late in the stroke that the exhaust valve opens before the charge is burnt, consequently the gas at very high temperature is passing between the valve and its seat. The cool gas, coming in on the suction stroke, will help the water cooling system to keep the valve cool, but even with this help it will not withstand the heat very long and is soon warped, allowing leakage during the compression stroke. The remedy is to adjust the throttle so that the engine may be run as slowly as desired with the spark advanced so that ignition does not take place so near dead center.

Answers Relating to the Control of the Change Speed Gears

Ques. What may be said with respect to shifting the change speed gears?

Ans. The proper handling of the transmission lever, on a sliding gear system, can only be obtained by practice. One of the best tests of a driver's skill is to notice the way he handles the change speed gears. A skillful man, accustomed to a car, will pass through all speeds, either up or down, noiselessly, unless for the click caused by the lever bringing up against the quadrant.

Ques. What difficulty is sometimes encountered by the beginner?

Ans. The two movements necessary to give the transmission lever with a selective type transmission.

Ques. How should this operation be performed?

Ans. In moving the lever, the driver should give it a slight lateral pressure as it approaches the neutral point. With a little practice, the change may be made with practically one motion, the lateral movement requiring no separate action.

In the mind of the average demonstrator and that of his pupil, (for the latter has it ground into him), there are but two

things to do in changing gears: release the clutch and push or pull the lever.

The beginner pushes or pulls the lever mechanically, and it is usually not until long after he has graduated that he comes to learn what actually happens in the gear box when he moves the lever.

Ques. What knowledge is necessary for the intelligent handling of the transmission lever?

Ans. The operator should understand the principles of operation of the transmission.

Ques. What condition is necessary in order that the gears may be shifted?

Ans. The teeth of the two gears that are to be brought into mesh, must be in a position to correspond, or nearly so. In order to facilitate the engagement of the gears, the teeth are rounded at the ends.

Ques. What condition is necessary for noiseless shifting of gears?

Ans. The two gears to be meshed must be revolving at as nearly the same speed as possible, therefore, when going into first speed the necessity for waiting a moment or two after declutching in order to allow the clutch shaft to slow down must be plain. If the lever be moved immediately the clutch is disengaged, it is practically the same as if an attempt were made to mesh the gears without going through the very necessary preliminary of taking the clutch out of engagement. Just how long it is necessary to wait must be a matter of experience in different types of cars.

The old conical clutch with its comparatively great diameter is apt to hold its momentum much longer than other types, such as the multiple disc, in which the discs are very small and light, although improvement along these lines has also made a vast difference in the earlier type, which is still adhered to by a number of prominent builders. In any case, the wait will not exceed a few seconds, but the difference in the result in the end of that time will be very perceptible as the gears are easily slid into mesh without any noise when the pinion on the clutch shaft is just about to come to rest. Waiting too long is not as bad as delaying the operation for too short a time, as the noise and damage will be proportionate to the relative speeds of the shafts, whereas in the former case, it is merely a matter of try again.

Ques. What precaution should be taken in shifting the gears?

Ans. Gears should not be forced into mesh. If they do not engage without being forced together, there is something radically wrong, and jamming down hard on the lever is only liable to aggravate the trouble or spring the shifting arm or lever.

Ques. What causes the noise or "growl" so frequently heard?

Ans. The incorrect handling of the transmission lever due to carelessness or ignorance of the driver.

Noise is not necessary in shifting the gears; it is caused by the attempt to force them together while they are travelling at different rates of speed. This serves to grind and chip the edges, occasionally breaking the teeth. No matter how easy an entrance has been provided by the designer of the car, the pinions cannot be slid together unless they happen to be revolving at approximately the same rate of speed, and the closer they are to this the better. Observation shows that the average driver seldom takes the precaution to wait before engaging the first speed to start, and noise and damage inevitably ensue. In changing to second speed, similar conditions obtain. The clutch shaft is revolving at a comparatively high rate of speed and the countershaft is going at a considerably slower rate. Hence, it is impossible to make the latter go any faster, and therefore an immediate and noiseless change is not possible.

Ques. What is the usual faulty method adopted in making the speed changes?

Ans. The transmission lever is usually moved simultaneously with the release of the clutch, and the result is to bring the speed of the clutch shaft down to that of the countershaft by the friction thus created between the sides of the pinions, to their resultant damage. The same result can be much better accomplished by a momentary halt between the operation of pulling the lever out of one speed and placing it home in the other, keeping the clutch fully disengaged in the interval. Here skill and experience in the handling of the make of car that one happens to be driving count, for if the wait be prolonged, the result will

be the same as if none had been indulged in, and the stop is apt to compel the momentary re-engagement of the clutch to again set the clutch shaft in motion.

Ques. What is the usual arrangement of the progressive system?

Ans. Generally the reverse gear is in mesh with the lever at the extreme rear, and high speed at the forward end of the quadrant, the intermediate speeds proportioned in between. The lever usually has a button on top, controlling a latch that locks in place at any desired speed by fitting into a slot cut in the quadrant.

Ques. What is the best method of securing the proper amount of travel from one speed to another with a progressive transmission?

Ans. The button or finger clasp that releases the latch from its slot is pressed, and while holding it released, the lever is moved far enough to prevent it slipping back into the slot when the button is released. The latch will now be pressing against the quadrant bar, and the lever can be moved until the desired gear is properly meshed, where the influence of the spring will pull the latch into the slot and lock the lever. If the latch be held released, the result may be that the lever will be carried too far into the following neutral. If this should occur, the operator must stop and again come back to first speed.

The progressive gear, as worked out by the Packard Company, does not have a locking device on the lever, the same result being obtained by a device in the gear box. When shifting from first to second, or from third back to second, the lever should be carried rapidly forward or backward until the gears are felt to engage. The locking device, though not automatic, will check the travel of the lever, and if the gears be properly in mesh, will provide sufficient resistance to the movement of the lever to assure the operator that the gears are correctly in mesh.

Ques. What attention should be given to a selective transmission?

Ans. It should be kept well oiled in order that the lever may freely slide sideways, also the operator's hand should be kept off the button unless it be desired to enter reverse.

It should be remembered that the button operates a stop which is provided as a safeguard; when the button is up the lever cannot enter reverse.

Some cars have appeared on the market with speeds arranged as follows:

R 2 4

I 3

If on a hill and conditions demand a change to a lower gear, say third back to second, the driver will have no trouble if he handle the lever without touching the button. If he should touch the button, he is almost sure to enter reverse, with possible serious consequences.

The clutch should be thrown as far forward as possible before any attempt is made to engage the gears. Some cars have appeared with only one pedal so arranged that the clutch is first released and further travel of the pedal applies the running brakes. The different types of clutch in use and the care bestowed on them have much to do with the ease with which the gears may be engaged.

The cone clutch, with its comparatively large diameter, is likely to spin longer than the multiple disc. Any attempt to mesh the gears while the clutch is spinning will result in the gears "growling," possibly chipping the teeth.

Occasionally the shaft will stop so that the teeth of one gear will strike those of the other and prevent them meshing. In this case, the clutch should be engaged again for an instant, thus letting the clutch shaft spin, and after giving the gears time to slow down, another attempt may be made to put them in mesh.

Answers Relating to the Brakes

Ques. What precaution should be taken in operating the brake?

Ans. The brake should never be applied with such force as to cause the tires to slip. The life of tires may be prolonged by the judicious and moderate handling of the brake lever.

Ques. What is the effect of locked wheels?

Ans. Much of the retarding effort is lost and rubber is ground off the tires, or if travelling on muddy roads or pavements all control over the car will be lost.

Ques. How should the speed of the car be controlled on long grades?

Ans. In descending a long incline, the brakes should not be depended on to hold the car. The ignition should be cut out, and, depending on the length and steepness of the grade, a suitable gear should be meshed and the car allowed to coast under compression, the brakes supplying any further retarding effort necessary.

Ques. What may be said of brakes in general?

Ans. Some brakes are intended to be lubricated, others are useless if oil reach the friction surfaces. When this happens, the best thing to do is to squirt a little gasoline on the drum. This will cut the oil and restore the efficiency. If one brake be adjusted tighter than the other it will throw the end of the car on that side around. Friction surfaces of metal to metal or steel to camel's hair or asbestos, will give little trouble with ordinary care. If leather be used, its life will be prolonged by releasing the brakes for an instant while in use. This will allow a current of air to pass between the surfaces and carry away some of the heat generated. The friction of the brake leather on the drum always generates heat, and the leather may be heated enough to be burnt or charred until useless unless the brake be used with moderation.

Answers Relating to Driving: Rules of the Road

Ques. What precautions should be taken in driving an automobile?

Ans. There are certain fixed rules of the road that must be observed, and rightly, too, if one is to avoid trouble, but the

motto of every driver should be: "Always be prepared for everyone else doing the wrong thing." By observing this rule, the driver will find himself armed for whatever may occur on the city streets. The first thing a new driver should do is to become familiar with the rules of the road.

In some places they are unwritten rules, but in most of the big cities the police have framed up regulations for the control of traffic, which, unfortunately in most cases, apply only to motor cars, the bluecoats being singularly nearsighted when it comes to noting infractions of the rules by drivers of horse drawn vehicles.

Ques. What is the first rule in driving?

Ans. **Keep to the right in passing a vehicle going in the opposite direction.**

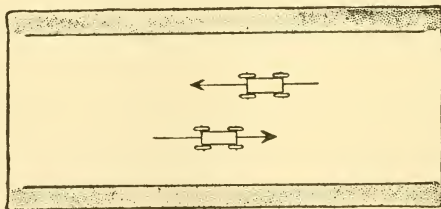

Fig. 351.—When two cars are going in opposite directions, the safe procedure is for each driver to keep well to the right of the crown of the road, thus avoiding the possibility of a collision.

Ques. What is the second rule?

Ans. **Keep to the left in passing a vehicle going in the same direction.**

Numerous accidents have been caused by failure to observe this rule. The driver who disregards this rule is liable for damages in case of accident, as a vehicle has a right to swing to the right at any time.

The non-observance of the above rule is sometimes due to the presence of electrics whose drivers generally stay in the middle of the street and run at about eight or ten miles an hour, which often compels others to invade forbidden territory to get by or else swing to the left directly into the path of the vehicles coming

from the other direction. Cases are seen daily where the drivers have had to go almost to the left curb in order to pass.

Ques. What is the proper method of turning a corner?

Ans. The driver should not cut diagonally across the street by beginning to turn before reaching the corner.

It is evident that such a procedure will cut off traffic coming from the other direction.

Ques. What is the road signal to indicate that the driver is about to turn a corner or stop?

Ans. The driver raises a hand or whip; the right arm extended means that it is unsafe for the man behind to come

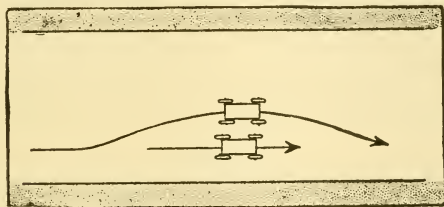

Fig. 352.—The driver should not pass to the right of a vehicle going in the same direction. He has no recourse in case of an accident caused by the other driver turning into the curb.

up on that particular side, because the signaler is preparing to turn a corner and needs room. The arm extended to the left means caution on that side. The right arm raised so that the arm is above the level of the head, with the forearm vertical and the shoulder portion horizontal, means that speed is about to be slackened, possibly because of the traffic or because of some manoeuver the driver wishes to make. It may be a case of reverse; then the horn should be sounded to call attention to the signal.

Another signal that is sometimes used when a driver desires the car behind to pass him or he has consented to give the right of way is to hold the right arm downward outside the body of the car and wave it forward.

The constant thrusting out of the hand, like an automaton or jumping Jack, as practiced by some drivers, should be avoided,

as it cheapens the signal, and results in less attention being paid to it on occasions of danger.

Ques. What precautions are necessary in driving along trolley lines?

Ans. As a rule, the track is laid on one side of the road, but there appears to be no recognized plan as regards location, and the autoist must keep a sharp lookout, not only for surprising changes in the location of the line but also for the cars themselves. In regard to the track itself, strict

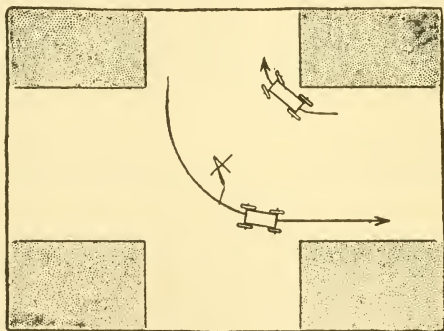

Fig. 353.—In turning corners, the driver of a vehicle turning to the left from the right hand side should pass the center of the street intersection before making a turn. In case he desires to make a right hand turn he should hug the curb as closely as possible in turning the corner.

watch should be kept for rails which are elevated above the level of the road, for switch tongues and differences in level between the bed of the track and the surface of the road. Any of the foregoing may interfere with the steering of the automobile if the wheels come in contact with them, and if the road be at all greasy, side slips are likely to occur.

Ques. What trouble is encountered from slippery rails?

Ans. If the tires get into the rail channels, they may be badly wrenched or even torn off when a change of direction is made.

Ques. What should be avoided with respect to the rails?

Ans. One of the commonest mistakes made is in running the car with all four tires in the channels, which undoubtedly makes smooth running but which also renders it difficult for the autoist to steer out of them again when he wishes to do so by any movement of the steering gear. When the rails are dry, only a short time will elapse before the tire will ride over the rail head and get clear, but with wet rails sometimes hundreds of feet are traversed before the tires are clear.

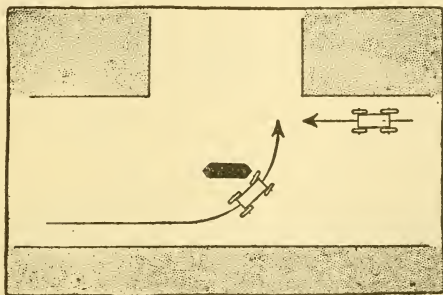

Fig. 354.—In turning corners where there are pedestrian refuges, drivers should use signals, a wave of the hand to the right asking the other driver to pause, while one to the left gives the right of way.

Ques. What precaution should be taken in crossing railroad tracks?

Ans. All tracks should be treated as if trains were likely to be due at the crossing at any moment; the car should be driven across at the greatest angle, and at the best speed possible. A sharp lookout should be kept in both directions and the car slowed down on approaching the crossing, taking absolutely no chances.

In case a collision be imminent, the steering wheel should be turned sharply in the direction in which the train is moving, so that the car will be struck a glancing blow, and the occupants will have some chance of escape.

Ques. What is the correct method of negotiating turns?

Ans. The car should keep to the center of the road and its speed reduced somewhat until the road is seen to be clear, when the turn can be made. In taking a right hand turn, the autoist should keep well away from the corner, describing as large an arc as possible and gradually gaining the center of the other road.

There are numbers of drivers who habitually shave corners; who start to take the turn before reaching the proper point and cut diagonally across the road, obstructing traffic coming in the opposite direction, and hugging the left hand corner of the intersecting road. Their desire is evidently to travel from one point

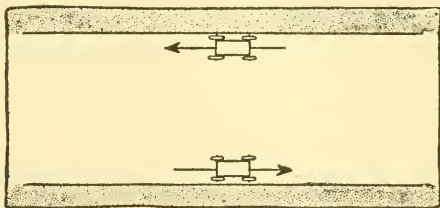

Fig. 355.—The rules of the road call for a machine or vehicle stopping with the right wheels to the curb.

to another in the shortest possible space of time, and to save distance cut the corners without regard to the rights or safety of others.

Because of the presence of reckless drivers, special caution has to be exercised at all times.

Ques. What difficulty is experienced in taking a curve, turning to the right?

Ans. Since the driver must keep to the right side, the camber of the road tilts the car in the wrong direction, which not only reduces its stability but in some cases causes the rear of the car to swing, especially on a wet road with marked camber.

Where the presence of an acute turn of this description is known, or indicated by a warning sign, the driver can be relied upon to reduce his speed, so as to be able to take it without unduly

stressing his running gear. But it is when the situation suddenly presents itself that matters assume a critical phase.

If the car be still running in a straight line when the nature of the corner becomes apparent, the engine should be switched off and the brakes judiciously applied without taking out the clutch, but if the corner has been entered upon, the greatest care should be exercised in using the brakes, because if the driving wheels become locked, a violent side slip would be inevitable.

If the corner has been entered upon, it will be wise to withdraw the clutch and trust to gentle braking with the side lever and good steering to get around. Advantage should be taken of every broken bit of road surface to assist the driving wheels in holding to the road.

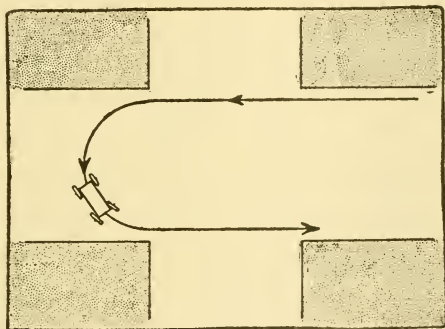

Fig. 356.—A good rule to observe and one that will prevent accidents is to go to the next corner before turning in a street. The turn should not be attempted until the farther corner has been reached, then a wide swing should be made, caution being observed, of course, to avoid vehicles going in both directions.

Ques. How should a greasy corner be taken?

Ans. For either a right or left turn, the driver can put the innerside wheels in the gutter, where they act as non-skids against the slope of the latter, and run round cautiously.

Ques. What is the proper method of taking a sharp turn?

Ans. It is best to run free for the sake of the differential gear, and if the rear of the car show an inclination to swing, gently letting in the clutch will cause the inside wheel to "bite" and the car will answer the wheel.

Ques. How should the car be run over faulty roadway?

Ans. When passing little breaks in the road, caused by water running off and carrying the road material with it, the shock of striking the edges is rather severe on tires and may be lessened by releasing the clutch for the moment and allowing the car to coast, always taking "waterbreaks" and similar rough spots straight on, so as not to strain the car unnecessarily.

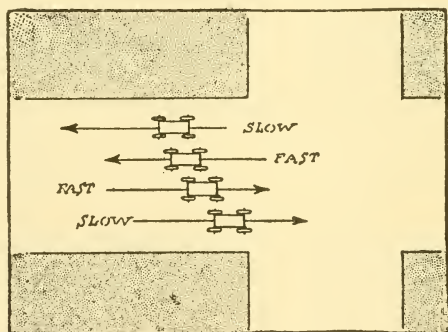

Fig. 357.—Slow moving vehicles should keep as near the curb as possible, leaving the central part of the road for faster moving rigs.

Ques. What precaution should be taken on approaching a point where the road forks or branches?

Ans. The autoist should hold well over to the proper side of the road in order to avoid cars coming along the branches. Should he be travelling along one of the branches towards the fork, however, he should keep in the center, as when approaching an ordinary turn.

Ques. What is "skidding?"

Ans. Skidding implies a continued forward movement of the car after the wheels have been locked by the brakes.

Ques. Explain the term "side slipping."

Ans. Side slipping relates only to a lateral motion of the car due to the wheels sliding bodily sideways.

Ques. How may side slipping be avoided?

Ans. Nothing but experience can teach the autoist how to evade side slip when the roads are in a slippery state. Deft manipulation of the steering wheel by an expert operator will often neutralize a well developed skid, by maintaining



Figs. 358 to 365.—The American Motor League "caution signs." Background and posts white, symbols black: 1, indicates approach to a steep descent; 2, approach to a railroad crossing; 3, approach to a branch road (to right); 4, approach to a branch road (to left); 5, approach to cross roads; 6, approach to a ditch or abrupt depression in the road; 7, approach to a hummock; 8, approach to a city, village, or other collection of inhabited dwellings; 9, is a general caution signal indicating the proximity of any danger or obstruction not indicated above, or any other condition requiring caution; 10, (not shown in cut) is a plain white sign and can be improvised in emergency cases by using a sheet of white cloth fastened upon a board of proper shape. Each sign is placed at a distance of not less than 200, not more than 300 yards from the point to which it refers.

the car in approximately its original line of onward movement. Thus, if the front wheels be steered in the direction in which the rear wheels are skidding, the tendency of the vehicle is to stay parallel to its original line of movement, ready to resume it as the skidding terminates.

There are certain kinds of surface on which the tires cannot obtain a firm grip, places in which lateral strains are brought to bear on the car, and acts on the part of the driver which either reduce or increase the adherence between the tires and the road.

Ques. What are the conditions encountered in operating a car at night?

Ans. Objects at night are deceiving to the eye. What appears as a dark patch in the road may be either a pool of water or a depression, and light colored objects by the side of the road may even be taken for the road itself. The road, too, apparently disappears a short distance ahead and the autoist sets the brakes, only to find himself deceived. Due to the combination of deep shadows and strong lights with the general gloom of the night, all sorts of objects created in the imagination seem to spring up, causing doubt and anxiety.

Running in city streets or on lighted roads, is, of course, much easier than running on dark roads, but in such cases the eyes are constantly accommodating themselves to the changes in light as the car approaches and passes a street lamp.

With the powerful arc lights in use in many cities, the view will be obscured for a short time as the car passes out of the circle thrown by the light, and a feeling of blindness will result, soon passing off, however, as the eyes adjust themselves to the change in quality of light. It is due to this effect on the eyes that a number of the minor accidents occur at corners, not only to autos but to horse vehicles and foot passengers.

When emerging from light into what seems total darkness, as when leaving the last light of a city and going along the unlighted road, an involuntary sensation of being lost is experienced and even with powerful headlights the feeling of blindness occurs for a short time.

Ques. What should be avoided at night?

Ans. Except when absolutely necessary, goggles should not be worn nor should the wind shield be raised, as the reflections from street lamps or other sources of light on the glass surfaces of the goggles and shield appear as direct lights, and obscure objects on the road.

OVERHAULING THE CAR

A thorough overhauling of the entire car is occasionally required, that the parts may be readjusted for wear and any needed repairs made. It is only by this care that the owner

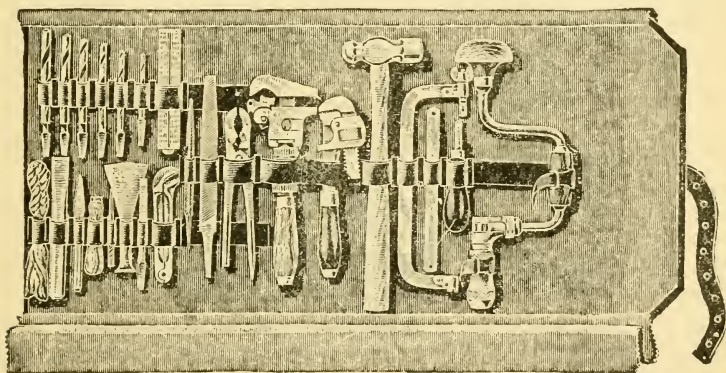

Fig. 366.—Kit of tools as usually carried on an automobile. With this outfit the driver can make adjustments and repairs such as arise from the ordinary mishaps likely to be encountered on the road.

can get an idea of the condition of the car, ascertain what parts show wear, and correct wrong adjustments which previously may have been made. The principal reason for taking an engine apart is to find the exact condition of the pistons and bearings as well as to remove any carbonized oil that may be found adhering to the cylinder walls.

Each part as it is removed should be cleaned. As soon as one part is unjointed or uncoupled, its pins or screws

should be inserted in their proper places before laying aside. This will prevent any small parts being misplaced.

Answers Relating to Overhauling

Ques. How may confusion be avoided in dissembling the car?

Ans. By providing a sufficient number of boxes to accommodate the several units of the car, and keeping everything pertaining to a certain part in its respective box.

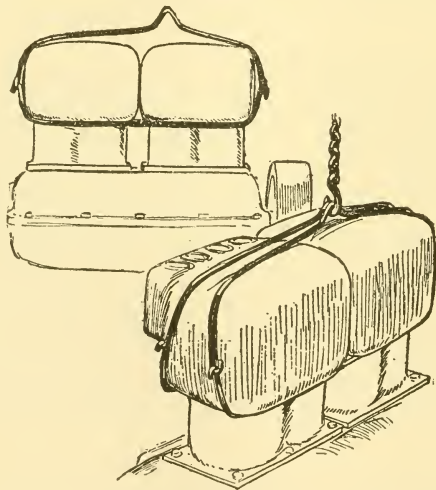

Fig. 367.—Steel slings to facilitate the removal of the engine. The slings are made of solid rolled steel about $\frac{3}{4}$ inch thick and each consists of two parts with hooked ends, having the hooks disposed at right angles to each other so that the two parts may be readily engaged or disengaged.

Ques. What should be removed from the engine?

Ans. The carburetter, pump, wiring, spark plugs, and other detachable parts.

Ques. What precaution should be taken in disconnecting the magneto?

Ans. The gear wheels of the engine and the driving pinion of the armature shaft should be marked with a punch

at the point where they mesh, if not marked already. By taking this precaution, the magneto may be assembled on the car in its proper place without disturbing the original timing.

Ques. What care should be taken with regard to the valves?

Ans. Each valve should be marked as it is taken out, that each may be replaced in its proper seat. It will be convenient to number them 1, 2, 3, etc., by punch mark.

Ques. Having removed the small parts, what should be done next?

Ans. The cylinder castings should be lifted off the pistons and removed to the work bench.

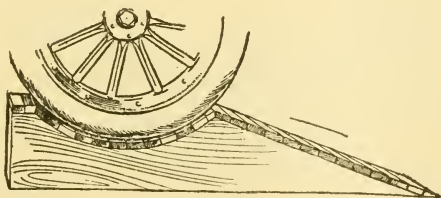

Fig. 368.—Substitute for a repair pit.

Ques. How should the cylinders be assembled, especially those cast in pairs, or *en bloc*?

Ans. In assembling without assistance, especially where the weight is considerable, the cylinders should be assembled with the pistons in their respective places, to avoid holding up the heavy casting while fitting the pistons.

Ques. What should be done after removing the cylinders?

Ans. Before taking down any other part of the car, it is a good plan to first clean out the cylinders with kerosene to soften deposits of carbon adhering to the walls. If the deposit be light, this soaking may be all that is

necessary, but where a considerable amount of carbon is present, the walls must be scraped either with a suitable carbon scraper, sold for the purpose, or with a file bent and sharpened to a cutting edge.

Ques. What attention should be given to the piston rings?

Ans. They should be cleaned; if any black streaks be found, it is a certain indication of leakage. All worn piston rings should be replaced.

Ques. How should the wrist pin be treated?

Ans. It should be examined for looseness and wear.

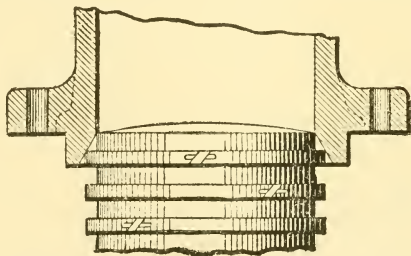

Fig. 369.—Sectional view of cylinder showing bevel at the end of the bore which is provided to facilitate the insertion of the piston.

It is important that the pin be a tight fit, otherwise it may work out and injure the cylinder walls. A loose piston pin may be due to the set screw becoming loose, or it may be caused by wear. In the latter event, the pin should be replaced with a new one of the proper diameter and length.

Ques. What preparation should be used in grinding the valves?

Ans. A mixture composed of emery, of the grade known as 120, mixed with kerosene and a few drops of heavy lubricating oil to give the mixture "body" is good for this purpose.

Ques. How are the cam shafts removed?

Ans. In most cars the cam shafts are removed by taking off the covers of the case which encloses the timing gears and pulling the cam shafts through this opening.

Ques. What precaution should be taken in assembling a cam shaft?

Ans. Care should be taken to see that the mark on the crank shaft gear registers with the mark on the cam shaft gear.

Ques. How should the radiator be cleaned?

Ans. Cleaning the radiator of grease or any scale that may have accumulated is best done after the car is reassembled and in running order. In cleaning the radiator, a cleaning mixture is made by dissolving one-half pound of lye in a bucket of water, stirring until dissolved. This

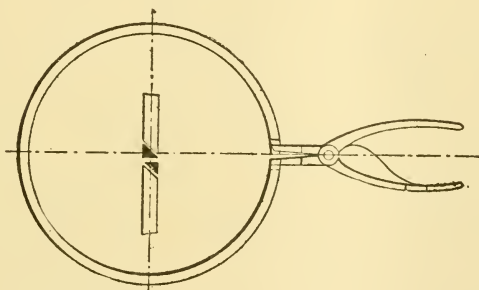

Fig. 370.—A useful tool for removing piston rings.

should be strained and the radiator filled with the mixture. The engine should be run for five minutes and then allowed to stand for one-quarter of an hour. The mixture may now be drained off and the radiator filled with **clean water**. The engine is again run for a few minutes, after which the radiator is drained and refilled with a fresh supply of water. The foregoing treatment will remove any grease deposits in the radiator.

Ques. What attention should be given to the transmission?

Ans. The transmission cover should be removed and the gears examined. As most transmission systems are fitted

with annular ball bearings, only a good cleaning to remove old grease will be required. In case any gears are badly worn and their edges chipped, they should be replaced with new ones.

Ques. How should the clutch be taken down?

Ans. The exact mode of procedure varies with different clutches. Usually a multiple disc clutch may be removed

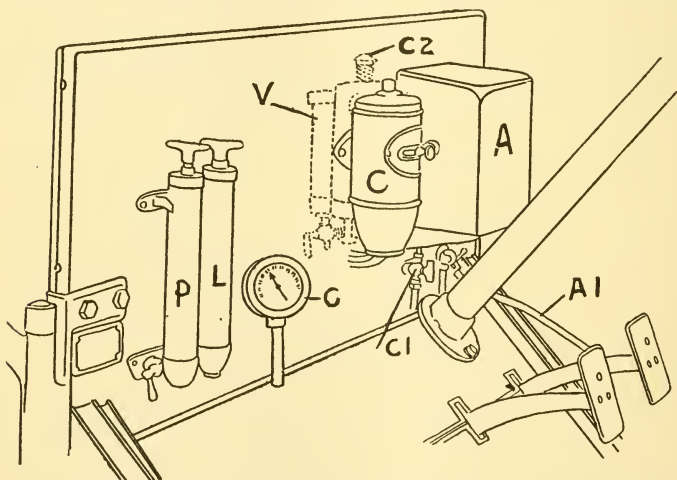

Fig. 371. Dash equipment of a modern car. A is a mahogany cover over the auxiliary gasoline tank; C represents the dash coil of the Bosch dual ignition system, P is the pump by means of which pressure may be supplied to the gasoline system and G is the gauge which tells how much pressure is on the gasoline system. V is the automatic pressure valve, shown in dotted lines, it being on the back of the dashboard under the hood; AI is the accelerator foot pedal. If the pressure on the gasoline system be not sufficient to cause the gasoline to flow into the auxiliary tank A, there will be a shortage of gasoline which will be indicated by opening the cock in the bottom of the tank. If it be desired to examine the carburettor to the extent of taking off the cover of the float bowl, the cock C1 may be closed to shut off the flow of gasoline to the carburettor.

as a unit; in other forms, the shaft connecting the shifting sleeve may be uncoupled, which gives sufficient room between the clutch and gear box to take the clutch apart. If the latter be of the cone type, it may be found that the leather

face is badly worn, and that a new leather is necessary. This is not a very difficult job, but requires painstaking work.

Ques. Describe the proper method of removing worn leather from the cone.

Ans. This is done by cutting off the rivets on the under side and driving them through to the outside. The old leather should be kept for use as a pattern by which to cut the new piece. It will be better, however, to purchase from the factory a new leather of the proper width and thickness.

Ques. How is a new leather attached to the cone?

Ans. As a new leather will have considerable "give" it must be stretched tightly over the cone. One end of the leather should be cut square and fastened to the cone with two rivets and the other end brought around to meet the fastened end. After tightly stretching it over the small end of the cone with a single rivet, the leather is then forced up onto the cone, holes drilled out and countersunk, and the leather riveted. The only knack in the operation is to keep the leather tight so that it may be a snug fit on the cone. A loose leather will naturally be a failure. After the leather has been forced into its place, the uncut end should be trimmed to make a good joint. Any unevenness may be trued with a file. The new leather will readily absorb several applications of castor oil before it becomes smooth and pliable.

Care should be taken that the rivet heads are countersunk below the surface of the leather. In case they work flush, owing to the wearing down of the leather face, they should be again riveted. The "biting" or jerky action of a cone clutch may be traced to the rivets working out, and this will frequently prevent the clutch being readily disengaged. Re-riveting will prove an effective remedy in this case, and considerable additional service may be had from the leather before it wears down to the rivet heads.

Ques. What attention should be given the differential gear?

Ans. It should be tested to locate any wear or side play. This may be done by jacking up the rear axle and turning one wheel forward and backward while the other is held stationary, noting how far the wheel must be turned before the movement is taken up by the fly wheel of the engine. Any noticeable play will generally be found either in center pinions or studs of the differential gear, in the large and small bevel gears, in the clutch sleeve, or in the universal joints.

The differential gear and live axle seldom give trouble if kept properly lubricated, and the mileage should run up into many thousands before any considerable amount of play is evident.

Ques. How is wear in the bevel gear taken up?

Ans. The small gear is adjusted to mesh deeper with its larger mate. This may be done by means of the adjustable locking ring or by inserting a washer of the proper thickness.

It may be found, however, that no adjustment is necessary, and a thorough cleaning with gasoline to remove all oil and grease will be all that is required. The case should then be refilled with the quantity of oil and grease recommended by the manufacturers.

Ques. What attention should be given to the universal joints in case of wear?

Ans. The joint pins should be replaced with new ones

Ques. How is the lubrication system cleaned?

Ans. The oil pipes or "leads" which conduct the oil to the bearings should be removed and all oil washed out by forcing gasoline through them. Care should be taken that the passages of all oil leads are clear and unobstructed. The oil pump should be taken apart and given a thorough cleaning with gasoline. The sight feed lubricator on the dash should also be cleaned out and the glasses wiped and washed out with gasoline.

Ques. What is the method of overhauling the steering gear?

Ans. It should be taken down, given a thorough cleaning, and examined for possible wear. In case the steering action be stiff and the wheel turn hard, the ball joint may be out of adjustment due to wear; the steering link may be bent, or the cause may be insufficient lubrication. If there be any considerable amount of back lash, the cause may be looked for in the joints of the levers, in the swivel pin, in loose bearings, or in wear of the worm and sector. Another common cause of back lash is often found in the wheels, which work out of alignment. It is essential that all moving parts of the steering gear be well lubricated.

The distance rod is easily bent, which throws the front wheels out of line. This is the common cause of "side slip" which rapidly wears out the tread of the tire. The bent rod should be uncoupled and carefully straightened. On many cars, however, the rod is designed to be bent, in order to clear other parts.

Ques. What attention should be given the wheels?

Ans. Each wheel should be removed and examined at the hub to see if the spokes have become loosened through shrinking. Although this is not a common fault, it is, nevertheless, worth looking for. If slightly loose, the bolts which secure the two side flanges together, should be tightened and the bearings cleaned with gasoline. Any ball or roller which is found damaged must be renewed. If rust has accumulated it should be removed with a scraper or sandpaper (a painter's wire brush is a handy tool), and, when perfectly clean, the rim should be coated with beeswax. This may be applied with a clean paint brush if the wax be heated to a liquid state. This will effectually prevent further rusting of the metal, and will do much to preserve the life of the tires.

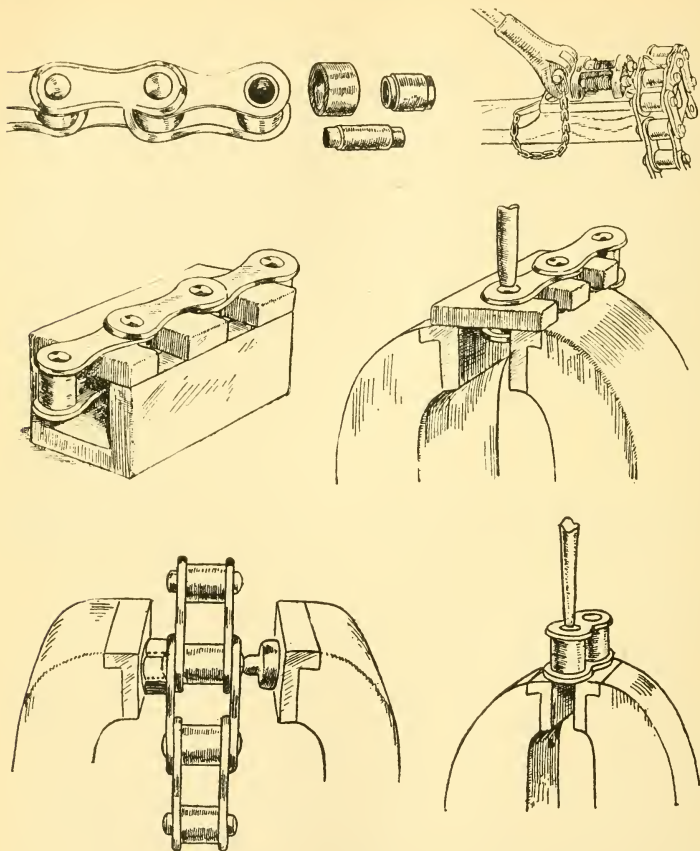

Figs. 372 to 377. Overhauling the chain; fig. 372, features of a riveted chain. To take apart this type of chain recourse is made to a special section of heavy channel iron and a plate which is recessed to receive a link of chain as illustrated in figs. 374 and 375 or to a special tool such as is shown in fig. 373. Two errors frequently made consist in an effort to remove the pins of the chain as shown in figs. 376 and 377. To assemble the chain, the parts should first be smeared with graphite and grease, and the roll slipped on; the ends of two side links are then pressed on to the ends of the bushing, which is designed for a driving fit, that is, a few light taps of a hammer should be all that is necessary to drive the links up to the shoulder on the ends of the bushing. The rolls and bushings at both ends of the link, of course, are assembled at the same time. To complete the assembly, the connecting side links are driven on to the ends of the pins, which are designed for a force fit, and the ends then are lightly peened over a mere trifle to secure them.

Ques. How are the brakes overhauled?

Ans. If worn, the old lining should be replaced with new. If the brakes be of the internal expanding type, the shoes may have become worn, in which case they should be renewed. Toggle joints and adjusting nuts should be inspected and any looseness taken up. Brakes should be adjusted on the road, as any improper adjustment of the equalizer bar will have a tendency to make the car skid. Both brakes should be adjusted alike in order that the braking force applied by the equalizer may be transmitted to the wheels equally.

Ques. What attention should the tires receive?

Ans. They should be cleaned of the old chalk on the inside of the shoe. If badly worn on the treads, but otherwise in good condition they should be sent to the factory to be retreaded. A tire should never be kept on the car after the rubber tread wears down so as to expose the fabric. Any small cuts and holes should be washed out and filled with rubber solution. Inner tubes should be tested for leaky valves, and patches attended to without delay. The old casings and tubes may be made to give considerable additional mileage by using them on the front wheels, where the strain is not so severe.

Ques. In overhauling the ignition apparatus, what should be done?

Ans. Worn tires should be replaced with new ones to guard against **breaks** or **partial breaks**. A timer should be cleaned with gasoline and lubricated with light oil. The magneto need not be taken apart, as it will probably only need a little surface cleaning, and a few drops of oil; the amateur had better not meddle with its internal mechanism. The storage battery should be examined, and if the brown deposit collect in any quantity at the bottom, the electrolyte

should be poured out into a glass bottle and the battery washed with clear water (rain water preferred).

Ques. What parts of the battery should be thoroughly cleaned?

Ans. The air vents, the top, and the terminals; the top should be kept free from acid, and the terminals free from corrosion.

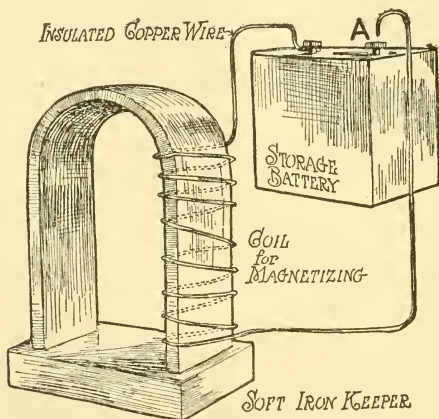

Fig. 378. One method of magnetizing a magnet. A coil of wire is wound around one leg of the magnet and one terminal connected to a storage battery. When the coil of the insulated wire has been wound around the magnet and the soft iron keeper is in place, the battery is short circuited several times by holding the loose end of the wire A in the hand and wiping it across the terminal of the battery. The resistance to an effort to remove the keeper will indicate the extent to which the magnet has become magnetized.

Ques. What other attention should be given the battery?

Ans. In case the battery be badly sulphated the electrolyte should be emptied and the case thoroughly washed with soft water. The case is then refilled with about seven-eighths of the electrolyte and the remainder with soft water. If the plates be broken down or "buckled," or if the paste has dropped out of the pockets in the grids, the battery should be sent to the manufacturer for repair.

Ques. How is the ignition coil overhauled?

Ans. The contact points will probably require adjusting. This is easily accomplished by truing the points with emery paper. The metal should not be rubbed away unnecessarily, only removing enough to true the points so that they make good contact. In adjusting the vibrator, it should be remembered that the tension is much better

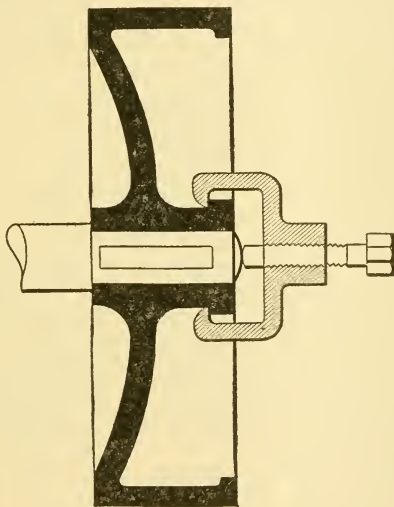

Fig. 379. Method of withdrawing fly wheel from crank shaft and the tool used for the purpose.

light than stiff. A light flexible vibration with a moderately high pitched buzzing note will not only give a better spark but will keep the points in better shape. A heavy tension will make the coil less responsive, and will pit the contact points and exhaust the battery more quickly. As a coil will render the most efficient service only when the vibrators are adjusted as nearly alike as possible, a special

ammeter is often used to determine the current consumption of each unit. The ammeter should show a reading of 6-10 amperes.

Ques. What method should be followed in assembling?

Ans. The parts should be assembled as soon as possible after taking down and cleaning, to guard against loss. In assembling the car, the engine had best be put together first. When putting the pistons in their respective cylinders, the splits or joints in the piston rings should not be in line, but spaced evenly around the piston. It is important that all parts be thoroughly clean and **that no grit or stray strands of waste remain on any projection.** All nuts and bolts should be screwed tight, being careful to properly adjust the jaws of the wrench to them, so that the corners of the nuts and cap screws may not be injured. Cotter pins should be inserted after each nut has been screwed home. In joints where packing is required, the old packing may be used if it be in good shape. Joint faces, should, of course, be perfectly clean. A stout grade of manila wrapping paper soaked in linseed oil will make an excellent packing for crank case and other joints having a good contact surface.

Ques. When and how is the valve timing checked?

Ans. It is well to do this while the engine is being assembled. To check the valve timing, the fly wheel is turned until the inlet valve plunger of #1 cylinder just touches the lower end of its valve stem. At this point the line on the fly wheel indicating "inlet #1 open" should coincide with the pointer on the engine base. If the contact between the valve stem and the plunger be made before the mark on the fly wheel lines up with the pointer, the valve opens too early. In most cars the adjustment may be made by the screw cap and lock nut on the plunger.

Ques. What attention do the valve stems sometimes require?

Ans. As the valve stems are lowered by repeated grinding of the valves, the plungers require adjustment occasionally to compensate for this movement. A piece of paper should be inserted between plunger and valve stem, and by lightly pulling on the paper the time of contact and the moment of release may be determined to a nicety. When the paper is held tightly, a good contact is secured, the moment the paper becomes loose and can be moved

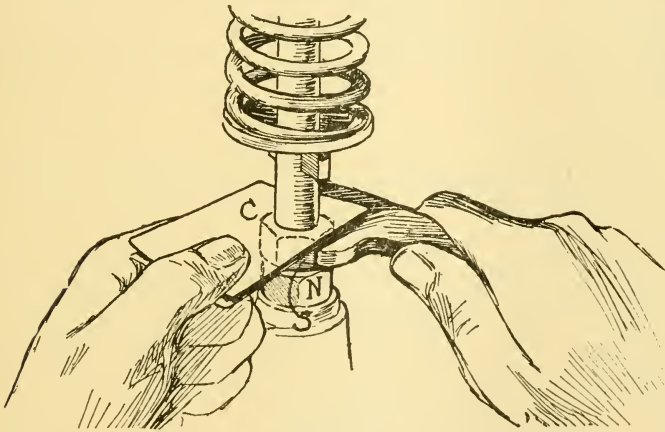

Fig. 380. Method of adjusting valve tappets. The space between the adjacent ends of the push rods and stems should be between $\frac{1}{16}$ and $\frac{1}{32}$ inch. In the absence of a suitable steel gauge, a common business card may be used. The card C is folded once and slipped between the ends of the stem and tappet, the lock nut N is loosened, and the stud S screwed up or outward until it just begins to pinch the card preventing it sliding about as readily as at first. The card is then removed and the lock nut tightened. When both the inlet and exhaust valves have been adjusted in this manner, each one should be individually tested with a single thickness of the card to see if the valves remain tightly closed throughout their required period. This is best done by sliding the single thickness of card gauge back and forth as the engine is being turned slowly from the closing to the opening points of each valve. The marks on the fly wheel may be used to advantage in this operation if accessible, but they are not necessary. The card may be moved under a stem and the engine turned until the card is seized, indicating valve opening, then a little further until it is free again, which marks the closing of the valve; now, by turning still further and continually sliding the card about, if the card be not seized before the regular time for the valve to open, according to either the position of the piston or crank handle, the adjustment is about right, and if the card be prematurely seized the space is insufficient. The valve in each cylinder should be adjusted in the same manner.

about, the contact is broken. In many cars the reference or index mark on the engine bed is omitted; in this case the markings on the fly wheel must be brought directly to the top. The other inlets and the exhaust valves should then be similarly checked up and adjusted.

Ques. What clearance is usually allowed between valve stem and plunger rod in timing?

Ans. About $\frac{1}{8}$ inch when the valve is closed. This may be taken as the minimum amount, and should not be increased. A larger amount of clearance will cause the exhaust valve to open too late, and the exploded gases, not being entirely expelled, the power of the engine will be impaired.

Ques. Why is this clearance necessary?

Ans. To allow for the expansion of the valve stem when it becomes heated.

Ques. What may be said about "system" in overhauling a car?

Ans. Too much stress cannot be laid on the necessity of going about the work in an orderly and methodical manner. A mechanic who leaves parts lying about carelessly will rarely be found a good one, and certainly he is not a proper model for the amateur to copy. With a little "horse sense" in applying the directions to his particular make of car, the amateur owner should have no difficulty in making a good job of overhauling, thus bettering the condition of his machine, and at the same time acquiring a valuable stock of knowledge for the future.

*"Knowledge is power, and the price of knowledge
is continued study"*

SELF-HELP
MECHANICAL
BOOKS

FOR

HOME STUDY

AND

REFERENCE



THEO. AUDEL & COMPANY

EDUCATIONAL PUBLISHERS

63 FIFTH AVE. ∴ ∴ NEW YORK

HAWKINS' MECHANICAL DICTIONARY

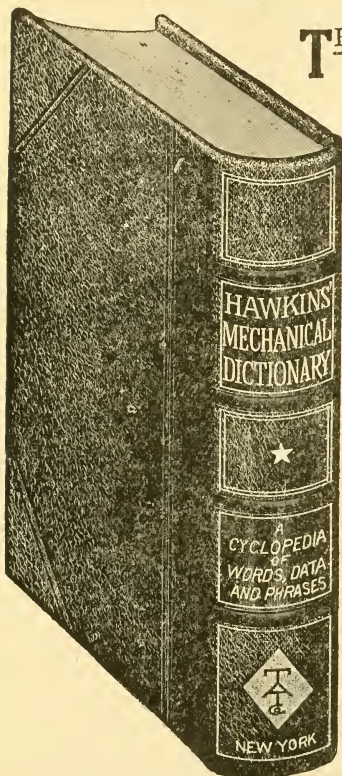

THIS volume is the most useful book in Mechanical Literature.

If constantly referred to will enable the student to acquire a correct knowledge of the words, terms and phrases in use in Mechanical Engineering and its various branches.

Its greatest value lies in this: that no man representing the mechanical profession can find excuse for not knowing the use and meaning of the terms used in his work.

Hawkins' Mechanical Dictionary explains and defines in plain language the use of all words and terms now used or heretofore used in the Mechanic Arts, Trades and Sciences.

It is an unequalled reference work, and is the one book of permanent value no student or expert should dispense with. Complete from A to Z. Highly endorsed. Price, \$3.50, postpaid.

HAWKINS' ELECTRICAL DICTIONARY

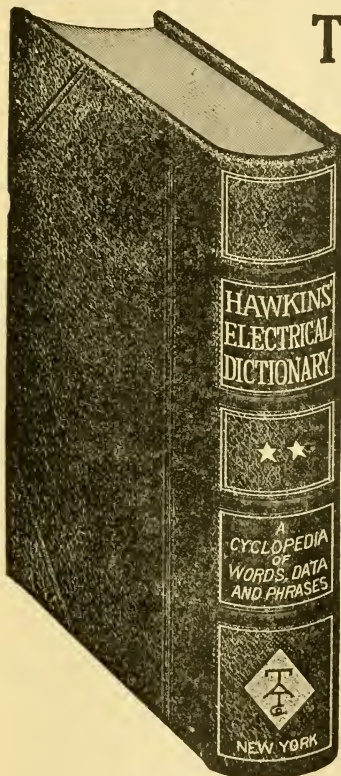

THIS work contains many books in one and is an entirely new and original work.

Clearly and plainly defining the full use and meaning of the thousands upon thousands of words, terms and phrases used in the various branches and departments of Electrical Science.

No Dictionary has to the knowledge of the publishers been printed to date that has kept pace with the rapid development of Electrical Engineering.

This Dictionary is not only a helpful book, but it adds largely to the use of all other Electrical and Scientific books, and we consider that no Library is complete or up-to-date, without this modern treasure of Electrical Science.

One valuable feature of this new work lies in the fact that it

is not only a comprehensive dictionary, but is also a Cyclopaedia of Electricity and Technology, compiled with accuracy and thoroughness.

Every progressive man in this wide field of effort needs this work and we urge upon the Scientific Reader the importance of owning a copy.

Besides containing a wealth of information this Dictionary, in point of manufacture, is in every way a high class and pleasing book, for study or for ready reference. Price, \$3.50, postpaid.

ERECTING AND OPERATING \$3
JUST ISSUED

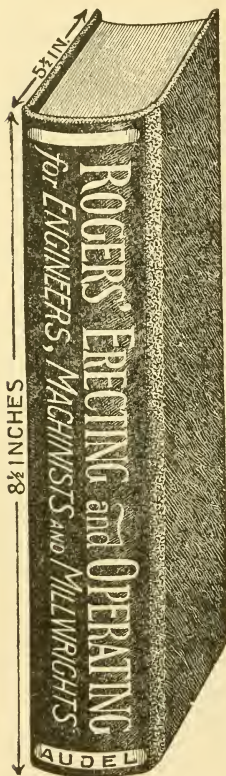

A PRACTICAL HANDBOOK on Excavations, Foundations, Structures, Millwrighting, Shafting, Belting, Piping, Boilers, Engines, Installing Machinery, etc.

In order to become an expert at the erection and operation of modern machinery and appliances, judgment must be added to execution; now as judgment cannot be taught in writing, further than in laying down certain principles of procedure, therefore the book is largely personal.

The method of instruction followed is to deal with the various subjects mentioned each consisting of nearly the same number of pages and illustrations, indicating the course of study.

Working Drawings, Foundations, Excavating, Piling and Grillage, Brick Work, Concrete Reinforced Concrete, Millwright's Tools, Steel Square and its uses, Bridge Work, Structures, Scaffolding and Staging, Rigging Knots, Hitches and Splices, Chains and Tackle, Steel Structure Work, Roofing, Blacksmithing, Tool Dressing, Belting and Pulleys, Shafting Lining, Speeds, Piping and Joints, Plumbing, Steam Boilers and Accessories, Chimneys, Drafts, Steam Engine Operation, Engine Foundations, Valve Setting, Water Power Installations, Steam Turbines, Pumping Machinery, Electrical Installations, Motors, Wiring, etc., Refrigerating Systems, Rules, Receipts, Metallic Compositions, Useful Tables, Ready Reference Index.

By following this plan and with the aid of the ready reference index to be found at the end of the volume, the work becomes a reference book, as well as a course of systematic study in Mill Engineering.

This volume is convenient in size, handsomely and durably bound in black cloth, having gold edges and titles; containing 800 pages, illustrated by over 500 drawings and illustrations of practical work. It is in every way a generously good book both in contents and manufacture.

PRICE \$3 to any address.

DRAWING AND DESIGN \$3

THIS volume is arranged for a comprehensive, self-instruction course for both shop and drawing room.

PLAN OF INSTRUCTION

Useful Terms and Definitions; Drawing Board, T-Square and Triangles; Lettering; Shade Lines; Section Lining; Ge-

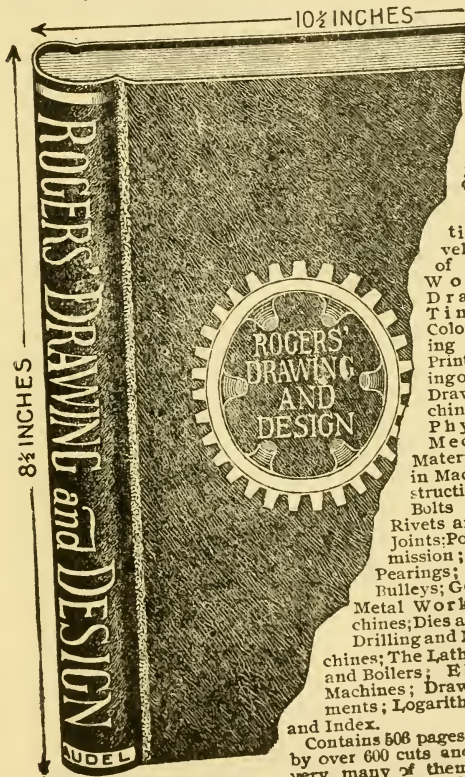

omet-
rical
Draw-
ing;
Iso-
metric
Pro-
jec-
tion;
Cab-

inet Pro-
jection;

Ortho-
graphic
Projec-
tion; De-

velopement
of Surfaces;

Working
Drawings;

Tints and
Colors; Trac-

ing and Blue
Printing; Read-

ing of Working
Drawings; Ma-

chine Design;
Physics and
Mechanics;

Materials Used
in Machine Con-

struction; Screws,
Bolts and Nuts;

Rivets and Riveted
Joints; Power Trans-

mission; Shafts and
Bearings; Belts and
Bulleys; Gear Wheels

Metal Working Ma-
chines; Dies and Presses;

Drilling and Milling Ma-
chines; The Lathe; Engines
and Boilers; Electrical
Machines; Drawing Instru-

ments; Logarithms; Tables
and Index.

Contains 506 pages, illustrated
by over 600 cuts and diagrams,
very many of them full page

drawings; the book is printed on a very fine grade of paper;

it measures 8 1/4 x 10 1/2 inches and weighs over 8 pounds; the
binding is in black cloth with gold edges and titles; the volume

is made to open freely and is in every way a most complete
up-to-date book.

PRICE, \$3 to any address.

ADVANCED MACHINIST \$2

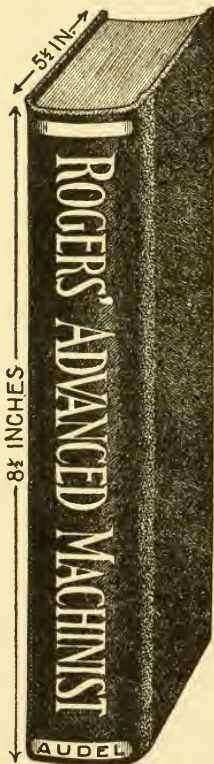

THE trade of the machinist is peculiar in that it is a preparation for so many positions outside of it.

It takes a man of good natural ability and of considerable education—not always from books—to make a first-class machinist; so that when one is well qualified he is also prepared for many other openings.

The aim of this work is to point the way of advancement to those who become fitted to assume these responsibilities and rewards.

The advanced machinist is a work of sterling merit, a few of the hundreds of subjects are here named, but they in no way show the scope of this work, which must be seen to be appreciated:

A Course in Machine Shop Mathematics; Various Measuring Instruments and Their Uses; Screw Cutting; Boring; Milling; Drilling; Grinding; Punching and Shearing; Bolt Cutting Machinery; Special and Auxiliary Machines; Shop Management: Work Shop Receipts and Devices, etc., etc.

The personal character of the book appeals to all in any way associated in the machinery and allied trades.

This book is a companion volume to Progressive Machinist and is uniform in binding and style, but more advanced in the subject of Machine Shop Practice, containing about the same number of pages, illustrations, etc.

PRICE, \$2, Postpaid

THEO. AUDEL & CO.

83 FIFTH AVENUE, NEW YORK

PROGRESSIVE MACHINIST \$2

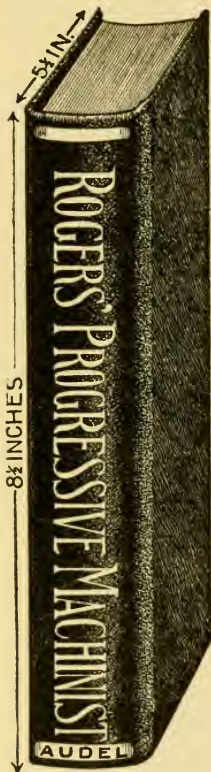

Lathe Practice; Measuring Instruments; Mandrels; Lathe-Dogs; Driving Work Between Centers; Turning Work Between Centers; Lathe Speed; Chuck and Face-plate Work; Drilling and Boring in the Lathe; Proportion of Parts of a Lathe; Useful References; Tables and Index.

Description of Binding.—The book is handsomely bound in black cloth, with gold edges and titles, printed on fine paper. Illustrated with 330 diagrams and drawings of practical work, containing over 360 pages of valuable information, and 1081 ready-reference index for quick information. This volume will be mailed to any address postpaid upon receipt of 2 dollars.

THIS is a valuable volume for all Metal Workers;—the following are a few of the many subjects treated:

Materials.—Definitions; Qualities of Matter; Iron, Steel; Various Metals, Alloys, etc.; Gravity and Tables; Three Laws of Motion; Strength of Materials; Fatigue of Metals; Table of Melting Points of Solids; Useful Weights and Measures.

Shop Drawing.—Free-hand Drawing; Instruments; Pencil-ing; Inking; Lettering Drawings; Dimensioning; Shading; Section Lining; Reading Working Drawings; Problems in Geometrical Drawing—Points Relating to Drawing.

Gearing.—Cog Wheels, Spur and Bevel Wheels; Mitre Wheel; Mortise Wheel; Worm Gearing; Helical Wheel; Designing Gears; Speed of Gear Wheels.

Bench and Vice.—Tempering and Hardening Metals; Grades of Steel; Cementation Process; Bessemer and Siemen-Martin Process; Case-Hardening; Annealing; Hand Tools; Machine Tools; Work Benches; Sledge and Anvil; Surfacing; Red Marking; Hand Drilling; Broaching; Screw Cutting by Hand; Pipe Cutting.

Tools and Machines.—Machine and Hand Tools; Portable Tools; Action of Machines; Classification of Machine Work; Turning and Boring; Planing; Milling; Drilling; Grinding; Punching and Shearing.

Lathe Work.—Forms and use of Foot Lathes; Hand Lathes; Chuck or Surfacing Lathe; Engine Lathe; Parts of the Lathe; Cutting Tools Used in the Lathe; Tempering of Lathe Tools Rule;

AUDELS GAS ENGINE MANUAL \$2

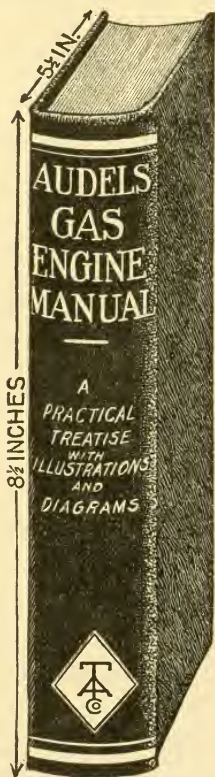

THIS volume just published gives the latest and most helpful information respecting the construction, care and management of Gas, Gasoline and Oil Engines, Marine Motors and Automobile Engines, including chapters on Producer Gas Plants and the Alcohol Motor.

The work is divided into 27 Chapters as follows:— Historical Development — Laws of Permanent Gases — Theoretical Working Principles — Actual Working Cycles — Graphics of the Action of Gases — Indicator Diagrams of Engine Cycles — Indicator Diagrams of Gas Engines — Fuels and Explosive Mixtures — Gas Producer Systems — Compression, Ignition and Combustion — Design and Construction — Governing and Governors — Ignition and Igniters — Installation and Operation — Four-Cycle Horizontal Engines — Four-Cycle Vertical Engines — Four-Cycle Double-Acting Engines — Two-Cycle Engines — Foreign Engines — Oil Engines — Marine Engines — Testing — Instruments Used in Testing — Nature and Use of Lubricants — Hints on Management and Suggestions for Emergencies — The Automobile Motor — Useful Rules and Tables.

Each chapter is illustrated by diagrams which make it a thoroughly helpful volume, containing 512 pages, 156 drawings, printed in large clear type on fine paper, handsomely bound in rich red cloth, with gold top and title, measuring $5\frac{1}{2} \times 8\frac{1}{2}$ inches and weighing over two pounds.

The book is a practical educator from cover to cover and is worth many times the price to any one using a gas engine of any type or size.

PRICE \$2.00 POSTPAID.

TWO. AUDEL & CO.,

63 FIFTH AVENUE, NEW YORK, N. Y.

MOTOR CAR PRACTICE \$2

A Good Book for Owners, Operators, Repairmen and Intending Purchasers.

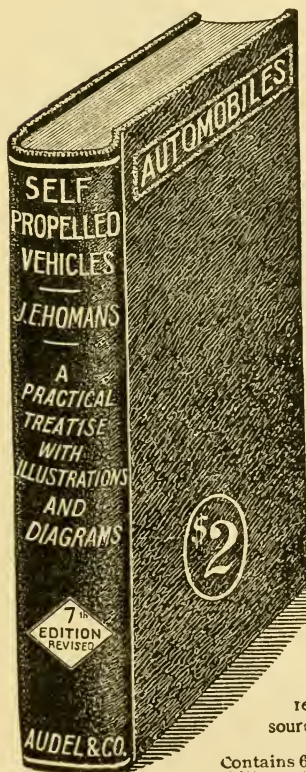

THIS work is now the accepted standard on the practical care and management of motor cars—explaining the principles of construction and operation in a clear and helpful way, and fully illustrated with many diagrams and drawings, making it of value to the intending purchaser, driver and repair man.

The subjects treat of the needs of the man behind the wheel, and are presented clearly, concisely and in a manner easy to understand by the reader, be he a beginner or an expert.

The treatise on the gasoline engine cannot fail to prove valuable to anyone interested in explosive motors, which are daily coming to the front as the readiest and most convenient source of power.

Contains 608 pages, over 400 diagrams and illustrations, printed on fine paper, size $5\frac{3}{4}$ by $8\frac{1}{4}$ inches with generously

PUMPS AND HYDRAULICS \$4

2 PARTS

IT is with pleasure we call your attention to the recent publication on pumping machinery. This work, issued under the title of "ROGERS PUMPS AND HYDRAULICS," is a complete and practical handbook treating on the construction, operation, care and management of pumping machinery, the principles of hydraulics being also thoroughly explained. The work is illustrated with cuts, diagrams and drawings of work actually constructed and in operation; the rules and explanations of the examples shown are taken from everyday practice. No expense has been spared in the endeavor to make this a most helpful instructor on the subject, useful to all pump attendants, engineers, machinists and superintendents.



Subjects Treated

The Air Pump, Air and Vacuum Pumps, Air Compressors; The Air Lift Pump; The Steam Fire Engine; Miscellaneous Pumps, Mining Pumps; Marine Pumps, "Sugar-house" Pumps; Circulating Pumps; Atmospheric Pumps; Ammonia or Acid Pumps; The Screw Pump; Aermotor Pumps; Rotary and Centrifugal Pumps; Turbine Pumps; Injectors and Ejectors; Pulsometer-Aqua-Thruster; Pump Speed Governors, Condensing Apparatus; Utilities and Attachments, Tools, Valves and Piping, Pipes, Joints and Fittings, Useful Notes, Tables and Data; Glossary of Pump and Hydraulic Terms. Elementary Hydraulics; Flow of water Under Pressure, Water Pressure Machines, Water Wheels; Turbine Water Wheels; Turbine Pumps; Water Pressure Engines; Hydraulic Motors; Hydraulic Apparatus; Hydraulic Jack, Hydraulic Press, Hydraulic Accumulator; Hydraulic Ram; Pumps as Hydraulic Apparatus; Classification of Pumps; Hand Pumps; Power Pumps; Belted Pumps; The Electric Pump; The Steam Pump, The Duplex Pump; Underwrite Fire Pump; Specifications of the National Board of Fire Underwriters Relating to Duplex Fire Pumps.

These two volumes of nearly nine hundred pages illustrated with about seven hundred wood cuts, are admirable specimens of bookmaking; they are printed on fine white paper in large clear text, with ample margins, and bound in black velum cloth with titles and tops in gold. In size they are six by nine inches.

PRICE, \$4, DELIVERED

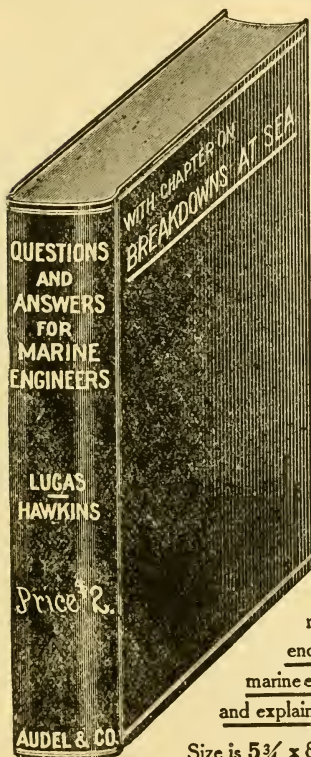

THIS treatise is the most complete published for the practical engineer, covering as it does a course in mathematics, the management of marine engines, boilers, pumps, and all auxiliary apparatus, the accepted rules for figuring the safety-valve.

The book is divided into two parts: Part I, Construction; Part II, Operation; it contains 700 pages.

The volume is illustrated with plate drawings, diagrams and cuts, having an Index with more than 1,000 ready references, 807 Questions on practical marine engineering are fully answered and explained.

Size is $5\frac{3}{4} \times 8\frac{1}{2}$ inches, $1\frac{1}{2}$ inches thick, and weighs nearly three pounds, strongly and durably bound in rich green cloth, with full gilt edges, and is the accepted standard on Marine Engineering.

Price \$2, sent free to any address in the world. Money will be refunded if not entirely satisfactory.

MECHANICAL DRAWING \$2

THE work has been carefully arranged according to the fundamental principles of the art of drawing, each theme being clearly illustrated. A list of the subjects are given below:

Chalk Work; Preliminary Terms and Definitions; Freehand Drawing; Geometrical Drawing; Drawing

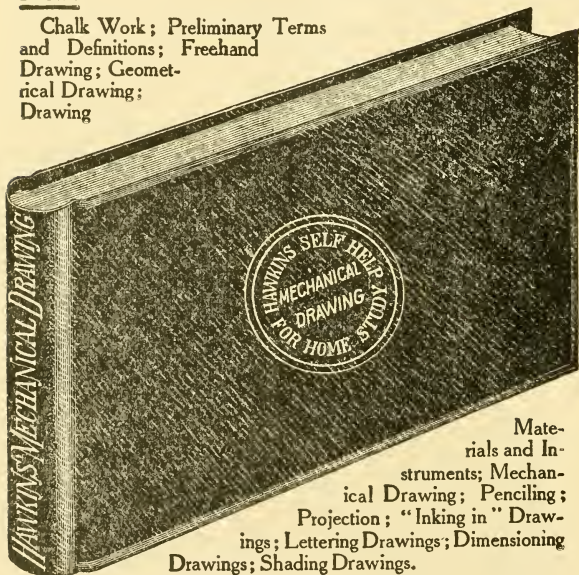

Materials and Instruments; Mechanical Drawing; Penciling; Projection; "Inking in" Drawings; Lettering Drawings; Dimensioning Drawings; Shading Drawings.

Section Lining and Colors; Reproducing Drawings; Drawing Office Rules; Gearing; Designing Gears; Working Drawings; Reading Working Drawings; Patent Office Rules for Drawings; Useful Hints and Points; Linear Perspective; Useful Tables; Personal, by the Editor.

The book contains 320 pages and 300 illustrations, consisting largely of diagrams and suggestive drawings for practice. It is bound in dark green cloth with full gold edges and titles; it is printed on fine paper, size 7x10 inches; it weighs 33 oz., and will fit into any engineer's or mechanic's library to good advantage.

PRICE, \$2, Postpaid

THO. AUDEL & CO.,

63 FIFTH AVENUE, NEW YORK

ELECTRICITY FOR ENGINEERS \$2

THE introduction of electrical machinery in almost every power plant has created a great demand for competent engineers and others having a knowledge of electricity and capable of operating or supervising the running of electrical machinery. To such persons this pocket-book will be found a great benefactor, since it contains just the information that is required, *explained in a practical manner.*

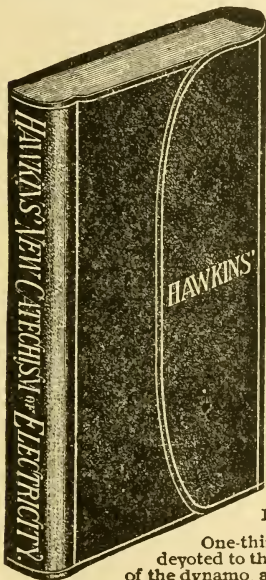

Plan of Study

The following is a partial list of the topics discussed and illustrated :

Conductors and Non-Conductors; Symbols, abbreviations and definitions relating to electricity; The Motor; The Care and Management of the Dynamo and Motor.

Electric Lighting; Wiring; The rules and requirements of the National Board of Underwriters in full; Electrical Measurements.

The Electric Railway; Line Work; Instruction and Cautions for Linemen and the Dynamo Room; Storage Batteries; Care and Management of the Street-Car Motor; Electro Plating.

The Telephone and Telegraph; The Electric Elevator; Accidents and Emergencies, etc., etc.

One-third of the whole book has been devoted to the explanation and illustrations of the dynamo, and particular directions relating to its care and management;—all directions being given in the simplest and kindly way to assist rather than confuse the learner.

It contains 550 pages with 800 illustrations of electrical appliances; it is bound in heavy red leather, (size $4\frac{1}{2} \times 8\frac{1}{2}$ for the pocket), with full gold edges and is a most attractive hand-book for Electricians and Engineers.

PRICE, \$2, Postpaid

THEO. AUDEL & CO.,

64 FIFTH AVENUE, NEW YORK

THIS work is an important aid to engineers of all grades, and is undoubtedly the most helpful ever issued relating to a safe and sure preparation for examination. It presents in a condensed form the most approved practice in the care and management of Steam Boilers, Engines, Pumps, Electrical and Refrigerating Machines, also a few plain rules

of arithmetic with examples of how to work the problems relating to the safety valve, strength of boilers and horse power of the Steam Engine and Steam Boiler.

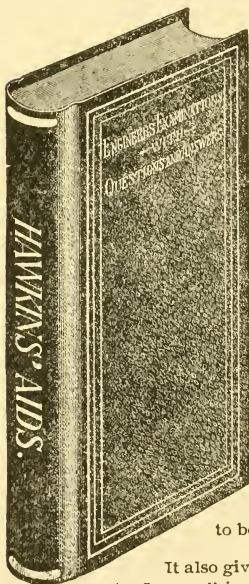

It contains various rules, regulations and laws of large cities for the examination of boilers and the licensing of engineers. It contains the laws and regulations of the United States for the examination and grading of all marine engineers.

The book gives the underlying principles of steam engineering in plain language, with very many sample questions and answers likely to be asked by the examiner.

It also gives a short chapter on the "Key to Success" in obtaining knowledge necessary for advancement in engineering.

This helpful volume contains 200 pages of valuable information not elsewhere obtainable; it is bound in rich red leather with full gold edges and titles; it measures 5x7 $\frac{1}{4}$ inches and weighs twenty-two ounces.

PRICE, \$2, Postpaid

STEAM BOILER PRACTICE \$2

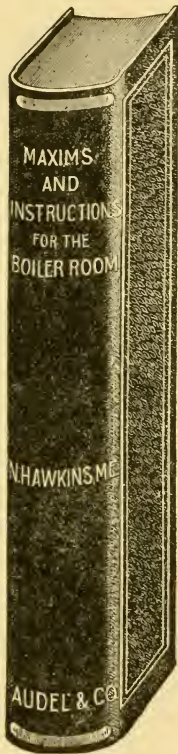

THIS book of instruction on boiler-room practice will be of great help to firemen, engineers and all others who wish to learn about this important branch of Steam Engineering.

It treats on materials, coals, wood, coke, and oil and gas, fuels, etc., their composition, properties, combustive value, also on combustion and evaporation.

Giving the practical rules to be observed in firing with various fuels, management of steam boilers, prevention of foaming; tools and fire irons; covering stationary, marine and locomotive boilers.

It enumerates sixty important points of cautions to be observed in the proper management of boilers.

It contains a description of and full treatise on stationary, marine and locomotive boilers, and the historical development of boilers; specifications for boilers; riveting; bracing; rules for finding pressure or strain on bolts.

It gives inspectors rules relating to braces in steam boilers. Also rules and tables for calculating areas and steam and water space of boilers.

It treats on boiler tubes, construction and drawing of boiler sections; defects and necessary repairs; inspection of steam boilers; mechanical stokers' corrosion and scale, boiler compounds, feed water heaters, injectors, pumps, boiler settings; pipes and piping; steam heating, chemistry of the furnace; boiler making; plumbing, and hundreds of other useful subjects.

It states several plain rules for the calculation of safety valve problems and those sanctioned by the U. S. inspectors.

The volume has 330 pages and 185 illustrations and diagrams. It is 6 x 8½ in. in size and weighs 28 ounces. The binding is uniform with that of the "Calculations" and "Catechism of the Steam Engine," being bound in heavy green cloth, with ornamental titles and edges in gold.

PRICE, \$2, Postpaid

THE G. AUDEL & CO.,

83 FIFTH AVENUE, NEW YORK

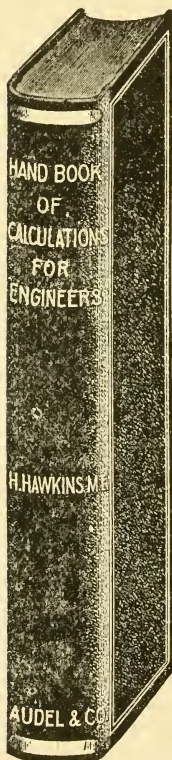

THE Hand Book of Calculations is a work of instruction and reference relating to the steam engine, the steam boiler, etc., and has been said to contain every calculation, rule and table necessary to be known by the Engineer, Fireman and a steam user.

Giving a complete course in Mathematics for the Engineer and steam user; all calculations are in plain arithmetical figures, so that the average man need not be confused by the insertion of the terms, symbols and characters to be found in works of so-called "higher mathematics."

Mechanical Powers; Natural or Mechanical Philosophy; Strength of Materials; Mensuration; Arithmetic Description of Algebra and Geometry.

Tables of Weights, Measures, Strength of Rope and Chains, Pressures of Water, Diameter of Pipes etc.; The Indicator, How to Compute; The Safety Valve, How to Figure; The Steam Boiler; The Steam Pump; Horse Powers, How to Figure for Engines and Boilers; Steam, What It Is, etc.

Index and Useful Definitions.

This work contains 330 pages and 150 illustrations, it is durably and handsomely bound, uniform in style and size with the "Instructions for the Boiler Room" and the "Catechism of the Steam Engine;" it has gold edges and titles, and weighs over 28 ounces.

PRICE, \$2, Postpaid

THEO. AUDEL & CO.,

63 FIFTH AVENUE, NEW YORK

STEAM ENGINE PRACTICE \$2



"It has been well said that engineers are born, not made; those in demand to fill the positions created by the great installations of power-producing machinery now so common, are men who are familiar with the contents of good books, and as well, are the product of a hard bought practical experience."

THIS work is gotten up to fill a long-felt need for a practical book. It gives directions for running the various types of steam engines that are to-day in the market.

A list of subjects, which are fully yet concisely discussed, are as follows:

Introduction; The Steam Engine; Historical Facts Relating to the Steam Engine; Engine Foundations; The Steam Piston; Connecting Rods; Eccentric; Governor; Materials; Workmanship; Care and Management; Lining up a Horizontal or Vertical Engine; Lining Shafting; Valve Setting; Condensers; Steam Separators; Air, Gas, and Compressing Engines; Compounding; Arithmetic of the Steam Engine; Theory of the Steam Engine; Construction.

There also is a description of numerous types of the engines now in operation, such as the Corliss, Westinghouse, and many others.

The book also treats generously upon the Marine, Locomotive and Gas Engines.

This is a rarely fine book, handsomely bound in green silk cloth, with full gold edges and titles; it contains 440 pages, 325 illustrations; in size it is 6x8 $\frac{1}{4}$ inches, and weighs 2 pounds.

PRICE, \$2, Postpaid

STEAM ENGINE INDICATOR \$1

THE work is designed for the use of erecting and operating engineers, superintendents, and students of steam engineering, relating; as it does, to the economical use of steam.

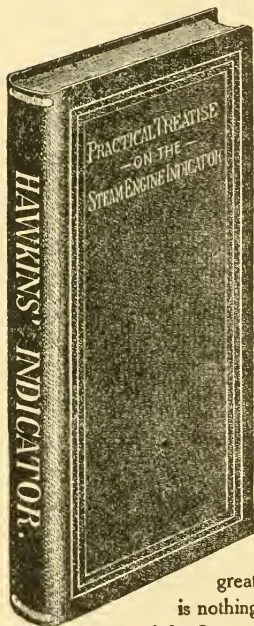

The following is a general outline of the subject defined, illustrated and presented most helpfully in the book.

Preparing the Indicator for use; Reducing Motions; Piping up Indicator; Taking Indicator Cards; The Diagram; Figuring Steam consumption by the diagram; Revolution Counters; Examples of Diagrams; Description of Indicators; Measuring Diagram by Ordinates; Planimeters; Pantographs, Tables, etc.

He who studies this work thoughtfully will reap great benefit and will find that there is nothing difficult or mysterious about the use of the Steam Engine Indicator. This knowledge is necessary to every well-informed engineer and will undoubtedly be highly appreciated and a stepping-stone toward promotion and better things.

The work is fully illustrated, handsomely bound, and is in every way a high grade publication.

PRICE, \$1.00

TELEPHONE ENGINEERING \$1

THE "A B C of the Telephone" is a book valuable to all persons interested in this ever-increasing industry. No expense has been spared by the publishers, or pains by the author, in making this the most comprehensive handbook ever brought out relating to the telephone.

TABLE OF CONTENTS

29 CHAPTERS

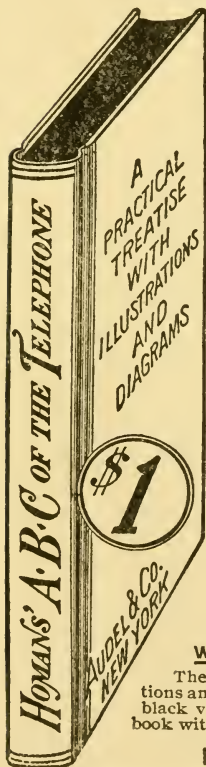

The Telephone Apparatus and its Operation; A Brief Survey of the Theory of Sound, Necessary to an Understanding of the Telephone; A Brief Survey of the Principles of Electricity; Electrical Quantities; History of the Speaking Telephone; Later Modifications of the Magnet Telephone; The Carbon Microphone Transmitter; The Circuits of a Telephone Apparatus; The Switch Hook and its Function in Telephone Apparatus; The Switchboard and the Appliances of the Central Station; The Operator's Switch Keys and Telephone Set; Improved Switchboard Attachments; Switchboard Lamp Signals and Circuits; The Multiple Switchboard; Locally Interconnected or Multiple Transfer Switchboard; Exchange Battery Systems; Party Lines and Selective Signals; Private Telephone Lines and Intercommunicating Systems; Common Return Circuits; Private Telephone Lines and Intercommunicating Systems; Full Metallic Circuits; Large Private Systems and Automatic Exchanges; Devices for Protecting Telephone Apparatus from Electrical Disturbances; The General Conditions of Telephone Line Construction; Telephone Pole Lines; Wire Transportations on a Pole Line. Telephone Cables and their Use in Underground and Pole Lines; Circuit Balancing Devices; The Microtelephone; Wireless Telephony; Useful Definitions and Hints on Telephone Management.

WITH READY REFERENCE INDEX

The volume contains 375 pages, 208 illustrations and diagrams; it is handsomely bound in black vellum cloth, and is a generously good book without reference to cost.

PRICE, \$1, Postpaid

TL 151.B7 1912x



3 9358 00143378 5

TL151

Booth, Charles Edwin

B7
1912x

Audels answers on automobiles,
for owners, operators, repairmen...
London, New York, T. Audel & co.,
1912.

143378, 17



TL 151.B7 1912x



3 9358 00143378 5